



## Acuvim II Series Power Meter User's Manual



**ACCUEVERGY**

The information contained in this document is believed to be accurate at the time of publication, however, Accuenergy assumes no responsibility for any errors which may appear here and reserves the right to make changes without notice. Please ask the local representative for latest product specifications before ordering.

Please read this manual carefully before installation, operation and maintenance of the Acuvim II Series Power Meter. The following symbols in this manual are used to provide warning of danger or risk during the installation and operation of the equipment.



Electric Shock Symbol: Carries information about procedures which must be followed to reduce the risk of electric shock and danger to personal health.



Safety Alert Symbol: Carries information about circumstances which if not considered may result in injury or death.

Prior to maintenance and repair, the equipment must be de-energized and grounded. All maintenance work must be performed by qualified, competent accredited professionals who have received formal training and have experience with high voltage and current devices. Accuenergy shall not be responsible or liable for any damages or injuries caused by improper meter installation and/or operation.

# Table of Contents

|  |           |
|--|-----------|
| <b>Chapter 1: Introduction</b> .....                           | <b>7</b>  |
| 1.1 Meter Overview.....  | 7         |
| 1.2 Areas of Application .....                                 | 8         |
| 1.3 Functionality.....   | 9         |
| <b>Chapter 2: Installation</b> .....                           | <b>14</b> |
| 2.1 Appearance and Dimensions.....                             | 16        |
| 2.2 Installation Methods .....                                 | 18        |
| 2.3 Wiring .....   | 22        |
| 2.3.1 Power Requirement .....                                  | 22        |
| 2.3.2 Voltage Input Wiring.....                                | 23        |
| 2.3.3 Current Input Wiring.....                                | 27        |
| 2.3.4 Typical Wiring.....                                      | 29        |
| 2.3.5 Frequently Used Wiring Methods.....                      | 30        |
| 2.3.6 Communication .....                                      | 32        |
| <b>Chapter 3: Meter Display &amp; Parameter Settings</b> ..... | <b>34</b> |
| 3.1 Display Panel and Keys .....                               | 34        |
| 3.2 Metering Data .....  | 36        |
| 3.2.1 Voltage and Current Data.....                            | 36        |
| 3.2.2 Power, Power Factor, and Frequency .....                 | 39        |
| 3.2.3 Phase Angles and Unbalance.....                          | 40        |
| 3.2.4 Energy .....   | 41        |
| 3.2.5 TOU Display.....   | 43        |
| 3.3 Statistical Data .....                                     | 45        |
| 3.4 Demand Data .....  | 46        |
| 3.5 Harmonic Data.....   | 47        |
| 3.5.1 Power Quality Data .....                                 | 47        |
| 3.5.2 Individual Harmonic Data.....                            | 48        |
| 3.6 Expanded I/O Module Data.....                              | 50        |
| 3.6.1 Module Selection.....                                    | 50        |
| 3.7 Meter Setting Mode.....                                    | 53        |
| 3.7.1 Password Inquiry.....                                    | 53        |
| 3.7.2 Parameter Selection Mode.....                            | 53        |

|   |           |
|---|-----------|
| 3.7.3 System Settings.....                              | 54        |
| 3.7.4 I/O Module Settings.....                          | 57        |
| 3.7.5 Communications Module Settings .....              | 59        |
| 3.7.6 Alarm Settings.....                               | 63        |
| 3.8 Page Recovery Function.....                         | 64        |
| <b>Chapter 4: Detailed Functions and Software .....</b> | <b>65</b> |
| 4.1 Acuvue Software .....                               | 65        |
| 4.1.1 Connect using RS485 .....                         | 65        |
| 4.2 Basic Analog Measurements.....                      | 68        |
| 4.2.1 High Speed Monitoring.....                        | 69        |
| 4.3 Demand .....  | 70        |
| 4.4 Energy .....  | 71        |
| 4.5 Max/Min.....  | 72        |
| 4.6 Harmonics and Power Quality Analysis.....           | 73        |
| 4.6.1 Harmonics & THD.....                              | 73        |
| 4.6.2 Amplitude and Angle.....                          | 74        |
| 4.6.3 Phase Angles .....                                | 75        |
| 4.6.4 Sequence Component and Unbalance Analysis.....    | 76        |
| 4.7 Alarm.....  | 78        |
| 4.7.1 Alarm Log .....                                   | 81        |
| 4.8 Meter Settings.....                                 | 83        |
| 4.8.1 Communication .....                               | 84        |
| 4.8.2 Wiring, CT/PT Ratios .....                        | 84        |
| 4.8.3 Demand Settings .....                             | 86        |
| 4.8.4 Energy Reading & Power Factor Settings .....      | 86        |
| 4.8.5 Load Percentage.....                              | 87        |
| 4.9 Time & Date Configuration.....                      | 88        |
| 4.10 Data Logging .....                                 | 89        |
| 4.10.1 Data Log Setting .....                           | 89        |
| 4.10.2 Retrieving the Data Log .....                    | 92        |
| 4.11 Time-of-Use (TOU).....                             | 93        |
| 4.11.1 General TOU Setting .....                        | 93        |
| 4.11.2 Monthly Billing Mode.....                        | 95        |
| 4.11.3 TOU Seasons.....                                 | 95        |
| 4.11.4 TOU Schedule .....                               | 96        |

|  |            |
|--|------------|
| 4.11.5 Weekend Settings.....                               | 97         |
| 4.11.6 Holiday Settings.....                               | 98         |
| 4.11.7 DST Settings .....                                  | 101        |
| 4.11.8 Reading the TOU data.....                           | 101        |
| 4.12 Power Quality Event Logging and Waveform Capture..... | 104        |
| 4.12.1 Waveform Capture.....                               | 105        |
| 4.12.2 Power Quality Event Logging .....                   | 107        |
| 4.12.3 Waveform Retrieval.....                             | 107        |
| 4.13 Dual Source Energy .....                              | 110        |
| 4.13.1 Controlling the Energy Direction .....              | 111        |
| 4.13.2 Bi-Directional Energy Switching Record .....        | 112        |
| 4.14 Seal Function.....                                    | 112        |
| 4.14.1 Sealed Nonstandard Parameters.....                  | 114        |
| <b>Chapter 5: Extended Modules .....</b>                   | <b>119</b> |
| 5.1 I/O Modules.....                                       | 119        |
| 5.1.1 Appearance and Dimensions.....                       | 119        |
| 5.1.2 I/O Functionality .....                              | 120        |
| 5.1.3 Installation Method .....                            | 123        |
| 5.1.4 I/O Module Wiring .....                              | 125        |
| 5.1.5 IO Module Readings.....                              | 131        |
| 5.1.6 Detection of Remote Signals.....                     | 131        |
| 5.1.7 Pulse Counter.....                                   | 134        |
| 5.1.8 Relay Output .....                                   | 138        |
| 5.1.9 Digital Output.....                                  | 140        |
| 5.1.10 Analog Output .....                                 | 144        |
| 5.1.11 Analog Input.....                                   | 148        |
| 5.2 Profibus Module AXM-PROFI.....                         | 151        |
| 5.2.1 Introduction of PROFIBUS Technology .....            | 151        |
| 5.2.2 PROFIBUS module application notes.....               | 151        |
| 5.2.3 Appearance and Dimensions.....                       | 152        |
| 5.2.4 Installation Method .....                            | 152        |
| 5.2.5 Definition of DP Interface.....                      | 153        |
| 5.2.6 Cable .....  | 153        |
| 5.2.7 Bus Terminal .....                                   | 153        |
| 5.2.8 Address Setting.....                                 | 154        |

|  |            |
|--|------------|
| 5.2.9 Baud Rate .....  | 155        |
| 5.2.10 GSD Files.....  | 155        |
| 5.2.11 Information Exchange .....  | 155        |
| 5.2.12 Format of Function code 01H .....                                 | 156        |
| 5.2.13 Format of function code 05H.....                                  | 157        |
| 5.2.14 Format of function code 02H.....                                  | 158        |
| 5.2.15 Format of function code 03H.....                                  | 159        |
| 5.2.16 Format of function code 10H.....                                  | 161        |
| 5.2.17 32 Word Output Interface .....                                    | 162        |
| 5.3 RS485 Module (AXM-485) .....   | 163        |
| 5.3.1 Communication Parameters Setting.....                              | 163        |
| 5.3.2 Function Description of RS485 module .....                         | 163        |
| 5.3.3 Appearance and Dimensions.....                                     | 164        |
| 5.3.4 Installation Method .....  | 164        |
| 5.3.5 Connection Method .....  | 165        |
| 5.3.6 Communication Address .....  | 166        |
| <b>Chapter 6: Communication Part I .....</b>                             | <b>167</b> |
| 6.1 Modbus Protocol Introduction.....                                    | 167        |
| 6.2 Communication Format.....  | 169        |
| 6.3 Data Address Table and Application Details .....                     | 173        |
| 6.3.1 Data Type.....   | 173        |
| 6.3.2 Relationship between communication value and numerical value ..... | 173        |
| 6.3.3 System Parameter Setting.....                                      | 175        |
| 6.3.4 System Status Parameters .....                                     | 178        |
| 6.3.5 Date and Time Registers.....                                       | 180        |
| 6.3.6 100ms Refresh Metering Parameters.....                             | 180        |
| 6.3.7 Real Time Metering Parameters.....                                 | 182        |
| 6.3.8 Energy Parameters.....   | 185        |
| 6.3.9 TOU (Time-of-Use) Registers .....                                  | 187        |
| 6.3.10 Power Quality Parameters .....                                    | 203        |
| 6.3.11 Max & Min Values.....   | 220        |
| 6.3.12 Phase Angles.....   | 226        |
| 6.3.13 Sequence Component .....  | 226        |
| 6.3.14 I/O Module Settings .....   | 227        |
| 6.3.15 I/O Module Readings Settings.....                                 | 233        |

6.3.16 SunSpec Registers .....239

**Chapter 6: Communication Part II ..... 244**

6.3.17 Over/Under Alarm Setting.....244

6.3.18 Data Logging .....253

6.3.19 Time-of-Use.....260

**Appendix ..... 289**

Appendix A Technical Data and Specifications .....289

Appendix B Ordering Information .....294

## Chapter 1: Introduction

### 1.1 Meter Overview

#### Powerful Multi-function Power Meter

The Acuvim II series multi-function digital power meter is designed using MCU (micro controller unit) and DSP (digital signal processing) technology. It integrates three-phase energy measuring and displaying, energy accumulating, power quality analysis, over-under alarming, data logging, and network communication. A vivid LCD with large characters and a time-of-use, programmable backlight provides a clear, real-time data readout.

#### Ideal for Electric Automation SCADA Systems

The Acuvim II series meter is the ideal choice for replacing traditional analog meters. In addition to providing clear real-time readings on the meter display, it can also be used as a remote terminal unit (RTU) for monitoring and controlling a SCADA system. Users can access all measurement parameters via the standard RS485 communication port (or the optional Ethernet port) with the Modbus protocol.

#### Energy Management

The Acuvim II series meter is able to measure bidirectional energy as well as four quadrant energy (kWh) and reactive energy (kvarh). It provides maximum/minimum records for power usage and power demand parameters. All power and energy parameters can be viewed remotely via software in order to easily monitor various parameters. In addition, measurement tables can be viewed from our free Acuvim software.

#### Remote Power Control

This meter is designed to measure and monitor power quality parameters. There are different I/O modules that can be added to the meter. This expands the meters capabilities and provides a very flexible platform for using the meter as a distributed RTU for metering, monitoring, and remote controlling all in one unit.

#### Power Quality Analysis

By utilizing digital signal processing (DSP) technology, the Acuvim II series meter provides high accuracy power quality analysis and supports remote monitoring via the Ethernet module. The meter continuously updates the metering results and allows users to access the meter online to monitor parameters such as voltage and current harmonics, voltage and current crest factors, voltage and current unbalance factors etc.

## Acuvim II Series Power Meter

---

### Data Logging

The Acuvim IIR meter and Acuvim IIW meter contain 8MB (megabytes) of on-board memory for data logging and historical trending respectively. Since the meters contain real-time clocks, all events and logged data will include a timestamp of when data is recorded.

### Time-of-Use

Users can assign up to 4 different tariffs (sharp, peak, valley, normal) to different time periods within a day according to the billing requirements. The meter will calculate and accumulate energy to different tariffs according to the meters internal clock and TOU settings.

### Power Quality Event Logging

When a power quality event occurs, such as voltage sag or swell etc, the Acuvim IIW meter will record the timestamp and the triggering condition of the event. It can save up to 50,000 power quality events.

### Waveform Capture

The Acuvim IIW contains another 8MB (megabytes) of on-board memory for power quality event logging and waveform capture. The Acuvim IIW can record 100 groups of voltage and current waveform. It logs at 64 points per cycle, and provides the waveform record of 10 cycles before and after the triggering point. It also supports a settable triggering condition.

## 1.2 Areas of Application

- Power Distribution Automation
- Industry Automation
- Energy Management Systems
- Renewable Energy
- Electric Switch Gear and Control Panels
- Building Automation
- Marine Applications

## 1.3 Functionality

### Multi-function

The Acuvim II meters provide powerful data collection and processing functions. In addition to measuring various parameters, the meter is able to perform demand metering, harmonic analysis, max/min statistic recording, over/under limit alarming, energy accumulating, and data logging.

### High Accuracy

The accuracy of voltage and current is 0.1% True-RMS.

The accuracy of power and energy is 0.1% while monitoring all four quadrants.

### Compact and Easy to Install

This meter can be installed into a standard ANSI C39.1 (4" round) or an IEC 92mm DIN (square) cutout. With the 51mm depth after mounting, the Acuvim II series meter can be installed in a small cabinet. Mounting clips are used for easy installation and removal.

### Easy to Use

All metering data and setting parameters can be accessed by using the keys on the front panel of the meter or by using Modbus via the communication port. Setting parameters are in the EEPROM (Electrical Erasable Programmable Read-Only Memory) so that content will be preserved when the meter is powered off.

### Multiple Wiring Modes

The Acuvim II series meter can be used in high voltage, low voltage, three-phase three wires, three-phase four wires and single-phase systems using different wiring mode settings.

### High Safety, High Reliability

The Acuvim II series meter was designed according to industrial standards. It can run reliably under high power disturbance conditions. This meter has been fully tested for EMC and safety compliance in accordance with UL and IEC standards.

## Acuvim II Series Power Meter

### Function Comparison of Acuvim II Series Meter

| Category             |  | Items                        | Parameters   | Acuvim IIR                               | Acuvim IIW |
|----------------------|--|------------------------------|--|--|------------|
| Metering             | Real-Time Metering                                 | Phase Voltage                | V1, V2, V3, Vinavg   | •  | •          |
|                      |  | Line Voltage                 | V12, V23, V31, Vllavg  | •  | •          |
|                      |  | Current                      | I1, I2, I3, In, Iavg   | •  | •          |
|                      |  | Power                        | P1, P2, P3, Psum   | •  | •          |
|                      |  | Reactive Power               | Q1, Q2, Q3, Qsum   | •  | •          |
|                      |  | Apparent Power               | S1, S2, S3, Ssum   | •  | •          |
|                      |  | Power Factor                 | PF1, PF2, PF3, PF  | •  | •          |
|                      |  | Frequency                    | F  | •  | •          |
|                      |  | Load Features                | Load Features  | •  | •          |
|                      |  | Four Quadrant Power          | Four Quadrant Powers   | •  | •          |
|                      | Energy & Demand                                    | Energy                       | Ep_imp, Ep_exp, Ep_total, Ep_net, Epa_imp, Epa_exp, Epb_imp, Epb_exp, Eqc_imp, Eqc_exp | •  | •          |
|                      |  | Reactive Energy              | Eq_imp, Eq_exp, Eq_total, Eq_net, Eqa_imp, Eqa_exp, Eqb_imp, Eqb_exp, Eqc_imp, Eqc_exp | •  | •          |
|                      |  | Apparent Energy              | Es, Esa, Esb, Esc  | •  | •          |
|                      |  | Demand                       | Dmd_P, Dmd_Q, Dmd_S, Dmd_I1, Dmd_I2, Dmd_I3  | •  | •          |
|                      | TOU  | Time-of-Use                  | Energy/Max Demand  | TOU, 4 Tariffs, 12 Seasons, 14 Schedules | •          |
| Daylight Saving Time |  | Two Formats Adjust           | Month/Day/Hour/Minute, Month/Week/First few weeks/Hour/Minute                          | •  | •          |
|                      | Waveform Capture (Not applicable on 400Hz systems) | Voltage and Current Waveform | Trigger, Manual, DI change, Sag/Dip, Swell, Overcurrent                                |  | •          |

| Category   |               | Items  | Parameters  | Acuvim IIR   | Acuvim IIW |   |
|------------|---------------|--|---|--|------------|---|
| Monitoring | Power Quality | Voltage Unbalance Factor                           | U_unbl  | •  | •          |   |
|            |               | Current Unbalance Factor                           | I_unbl  | •  | •          |   |
|            |               | Voltage THD  | THD_V1, THD_V2, THD_V3, THD_Vavg                        | •  | •          |   |
|            |               | Current THD  | THD_I1, THD_I2, THD_I3, THD_lavg                        | •  | •          |   |
|            |               | Individual Harmonics                               | Harmonics 2nd to 63rd<br>if 400Hz Harmonics 2nd to 15th | •  | •          |   |
|            |               | Voltage Crest Factor                               | Crest Factor  | •  | •          |   |
|            |               | TIF  | THFF  | •  | •          |   |
|            |               | Current K Factor                                   | K Factor  | •  | •          |   |
|            |               | Statistics   | MAX with Timestamp<br>MIN with Timestamp                | Each phase of V & I;<br>Total of P, Q, S, PF & F;<br>Each phase THD of V & I;<br>Unbalance factor of V & I                                 | •          | • |
|            |               | Alarm  | Over/Under Limit Alarm                                  | V, I, P, Q, S, PF, V_THD & I_THD each phase and total average;<br>Unbalance factor of V & I;<br>Load type;<br>Analog Input of each channel | •          | • |
|            | Others        | Power Quality Event Logging (N/A on 400Hz systems) | Sag/Dip, Swell  |  | •          |   |

## Acuvim II Series Power Meter

| Category      |                      | Items  | Parameters   | Acuvim IIR | Acuvim IIW |  |
|---------------|----------------------|--|--|------------|------------|--|
| Others        | Data Logging         | Data Logging 1<br>Data Logging 2<br>Data Logging 3 | F, V1/2/3/Inavg, V12/23/13/Inavg, I1/2/3/n/avg, P1/2/3/sum, Q1/2/3/sum, S1/2/3/sum, PF1/2/3, PF, U_unbl, I_unbl, Load Type, Ep_imp, Ep_exp, Ep_total, Ep_net, Eq_imp, Eq_exp, Eq_total, Eq_net, Es, THD_V1/2/3/avg, THD_I1/2/3/avg, Harmonics 2nd to 63rd, Crest Factor, THFF, K Factor, sequence and phase angles, DI counter, AI, AO, Dmd P/Q/S, Dmd I1/2/3Epa_imp; Epa_exp; Epb_imp; Epb_exp; Epc_imp; Epc_exp; Eq_imp; Eq_exp; Eqb_imp; Eqb_exp; Eqc_imp; Eqc_exp; Esa; Esb; Esc | •          | •          |  |
|               | On-board Memory Size | Memory   | Bytes  | 8MB        | 16MB       |  |
|               | Communication        | RS485 Port, Half Duplex, Optical Isolated          | Modbus-RTU/BACnet MSTP   | •          | •          |  |
|               | Time                 | Real Time Clock                                    | Year, Month, Date, Hour, Minute, Second  | •          | •          |  |
|               | 400Hz                |  | Only support full-wave energy, support 2nd ~ 15th individual harmonics   | •          |            |  |
| Option Module | I/O Option           | Switch Status (DI)                                 | Digital Input (Wet)  | •          | •          |  |
|               |                      | Power Supply for DI                                | 24 Vdc   | •          | •          |  |
|               |                      | Relay Output (RO)                                  | NO, Form A   | •          | •          |  |
|               |                      | Digital Output (DO)                                | Photo-Mos  | •          | •          |  |
|               |                      | Pulse Output (PO)                                  | By Using DO  | •          | •          |  |
|               |                      | Analog Input (AI)                                  | 0(4)~20mA, 0(1)~5V   | •          | •          |  |
|               |                      | Analog Output (AO)                                 | 0(4)~20mA, 0(1)~5V   | •          | •          |  |
|               | Communication        | Ethernet   | Modbus-TCP, HTTP, SNMP, SMTP, SNTP   | •          | •          |  |
|               |                      | Profibus-DP  | Profibus-DP/V0   | •          | •          |  |
|               |                      | The second way RS485 Module                        | Modbus-RTU Protocol  | •          | •          |  |
|               |                      | BACnet   | IP   | •          | •          |  |
|               |                      |  |  |            |            |  |
|               |                      |  |  |            |            |  |

• : Function    ◦ : Optional    Blank: N/A



## Chapter 2: Installation

### Considerations When Installing Meters

- Installation of the meter must be performed by qualified personnel only, who follows standard safety precautions through the installation procedures. Those personnel should have the appropriate training and experience with high voltage devices. Appropriate safety gloves, safety glasses and protective clothing are recommended.
- During normal operation, dangerous voltage may flow through many parts of the meter including the terminals, any connected Current Transformers (CTs) or Potential Transformers (PTs), all I/O modules and their circuits. All primary and secondary circuits can produce lethal voltages and currents. **AVOID** contact with any current carrying surfaces.
- The meter and its I/O output channels are **NOT** designed as primary protection devices and shall **NOT** be used in primary circuit protection or in an energy limiting capacity. The meter and its I/O output channels can only be used as secondary protection. **AVOID** using the meter under situations where failure of the meter may cause injury or death. **AVOID** using the meter for any application where risk of fire may occur.
- All meter terminals should be inaccessible after installation.
- Do **NOT** perform Dielectric (HIPOT) test to any inputs, outputs, or communications terminals. High voltage testing may damage the meter's electronic components.
- Applying more than the maximum voltage to the meter and/or its modules can withstand will permanently damage the meter and/or its modules. Please refer to the specifications for all devices before applying voltage.
- When removing the meter for service, use shorting blocks and fuses for the voltage leads and power supply to prevent hazardous voltage conditions or damage to CTs. CT grounding is optional.
- Accuenergy recommends using a dry cloth to wipe the meter.



**NOTE:** IF THE EQUIPMENT IS USED IN A MANNER NOT SPECIFIED BY THE MANUFACTURER, THE PROTECTION PROVIDED BY THE EQUIPMENT MAY BE IMPAIRED.



**NOTE:** THERE IS NO REQUIRED PREVENTIVE MAINTENANCE OR INSPECTION NECESSARY FOR SAFETY. HOWEVER, ANY REPAIR OR MAINTENANCE SHOULD BE PERFORMED BY THE FACTORY.

**DISCONNECT DEVICE:** The following part is considered the equipment disconnect device:

A SWITCH OR CIRCUIT-BREAKER SHALL BE INCLUDED IN THE INSTALLATION. THE SWITCH SHALL BE IN CLOSE PROXIMITY TO THE EQUIPMENT AND WITHIN EASY REACH OF THE OPERATOR. THE SWITCH SHALL BE MARKED AS THE DISCONNECT DEVICE FOR THE EQUIPMENT.

**FCC Compliance Statement** (e.g., products subject to Part 15)

This device complies with Part 15 of the FCC Rules. Operation is subject to the following two conditions:

1. This device may not cause harmful interference, and
2. This device must accept any interference received, including interference that may cause undesired operation.

The installation method is introduced in this chapter. Please read this chapter carefully before beginning installation.

## Acuvim II Series Power Meter

### 2.1 Appearance and Dimensions

There are two different types of Acuvim II meter design, either panel mount with an LCD display or DIN rail mount with no display. The following figures provide the front view, side view, and rear view of the two different Acuvim II series meters.

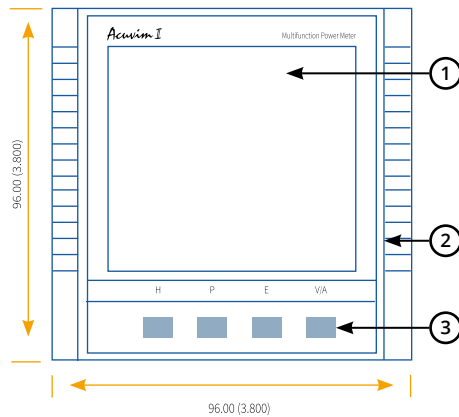

Figure 2-1 Front view of the Meter Display and Remote Display Unit

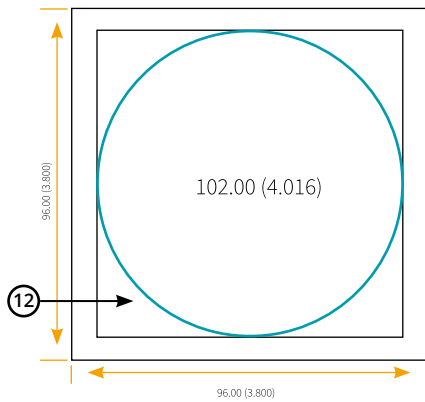

Figure 2-2 Rubber Gasket

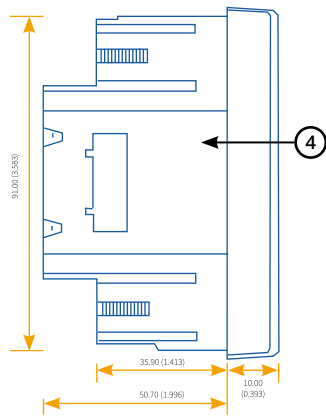

Figure 2-3 Side View of Meter With Display

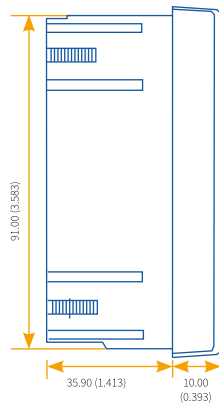

Figure 2-4 Side View of Remote Display Unit

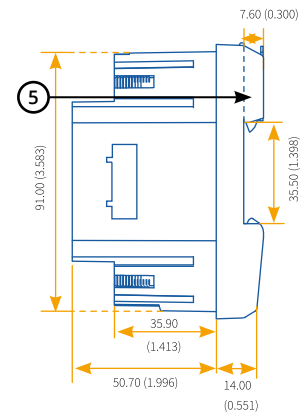

Figure 2-5 Side View of DIN Rail Meter

Unit: mm (inches)

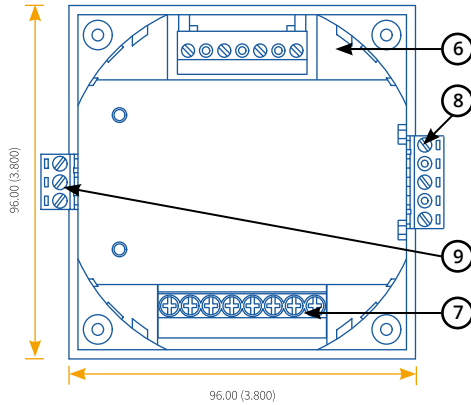

Figure 2-6 Rear View of Acuvim II Meter

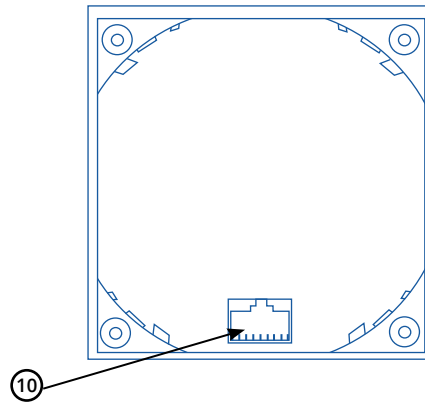

Figure 2-7 Rear View of Remote Display

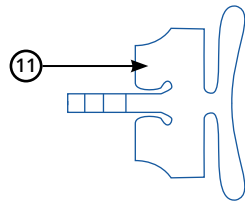

Figure 2-8 Installation Clip

Unit: mm (inches)

The table below specifies the part name and description of the Acuvim II series meter.

Table 2-1 Meter Part Name and Description

| Part Name                  | Description   |
|----------------------------|---|
| 1) LCD Display             | Large bright white backlight LCD display.   |
| 2) Front Casing            | Visible portion (for display and control) after mounting onto a panel.                                |
| 3) Key                     | Four keys are used to navigate through the display and configure settings.                            |
| 4) Enclosure               | The Acuvim II series meter enclosures are made of high strength anti-combustible engineering plastic. |
| 5) DIN rail                | Used for installation of 35mm rail of the DIN rail meter.   |
| 6) Voltage Input Terminals | Used for voltage input.   |
| 7) Current Input Terminals | Used for current input.   |
| 8) Power Supply Terminals  | The Control Power Input.  |
| 9) Communication Terminals | The RS485 communication port on the meter.  |
| 10) Interface              | Used for linking the remote display unit and the DIN rail meter.                                      |
| 11) Installation Clip      | Used for fixing the meter to the panel.   |
| 12) Gasket                 | Rubber gasket inserted between the meter and the cutout to cover up gaps from the round hole.         |

## Acuvim II Series Power Meter

### 2.2 Installation Methods

#### Environmental

Before installation, please check the environment, temperature, and humidity to ensure that the Acuvim II series meter is being placed where optimal performance will occur.

#### Temperature

- Operation: -25°C to 70°C
- Storage: -40°C to 85°C

#### Humidity

- 5% to 95% non-condensing

The Acuvim II series meter should be installed in a dry and dust-free environment. Avoid exposing meter to excessive heat, radiation, or high electrical noise source.

### Installation Steps

The Acuvim II series meter can be installed into a standard ANSI C39.1 (4-inch round) or an IEC 92mm DIN (square) form.

#### Panel Mount Installation

1. Cut a square hole or round hole on the panel of the switch gear. The cutting size can be seen in Figure 2-9.

Unit: mm (inches)

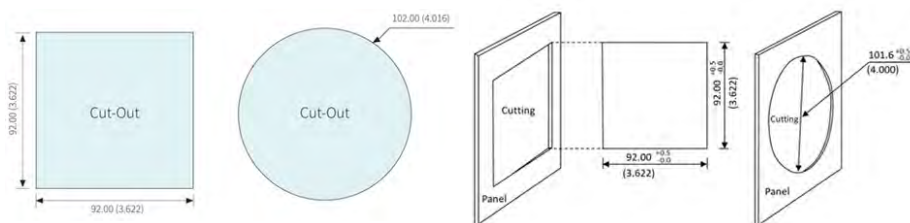

Figure 2-9 - Panel Cutout

2. Remove the clips from the meter and insert the meter into the square hole from the front side.

**NOTE:** Optional rubber gasket must be installed on the meter before inserting the meter into the cutout.

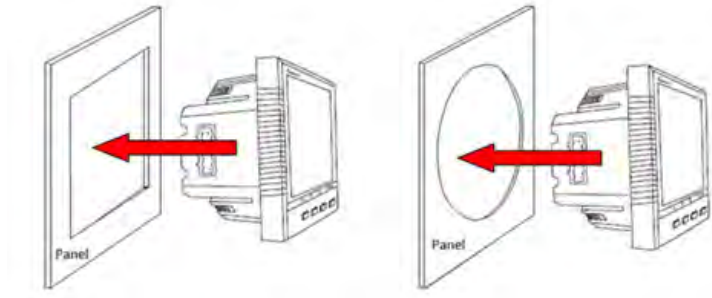

Figure 2-10 - Insert meter into the opening

3. Install the clips on the back side of the meter and secure tightly to ensure that the meter is affixed to the panel.

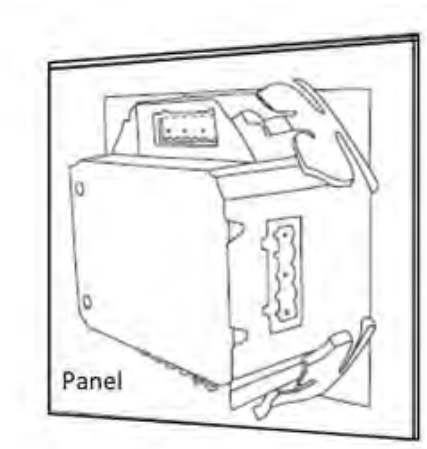

Figure 2-11 - Use the clips to fix the meter to the panel

**NOTE:** The display of the meter and the remote display unit have the same installation method. The DIN rail meter is simply installed on a 35mm DIN rail.

## Acuvim II Series Power Meter

### DIN Rail Installation Method

1. The DIN rail mount option meter is simply installed on a 35mm DIN rail.



### AXM-DIN Installation

The AXM-DIN rail adapter provides an easy installation method for panel-mount Acuvim II series meters on DIN rail. Available for all models and I/O options.

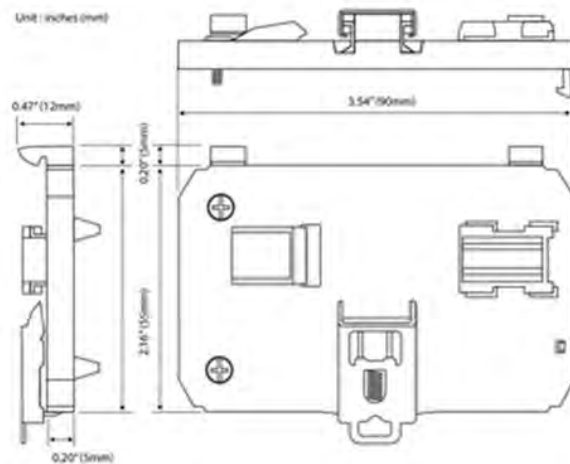

Figure 2-12 - Use the clips to fix the meter to the panel

1. The adapter can be installed directly onto the back of the Acuvim II meter, I/O module, or communications module, if used. Simply hook and screw the ends into the meter base. Once installed, snap the adapter into the 35mm DIN rail.



Figure 2-13 - Install the AXM-DIN rail adapter

2. The AXM-DIN rail adapter can be adjusted for horizontal or vertical DIN rail installations.



Figure 2-14 - Horizontal DIN rail installation

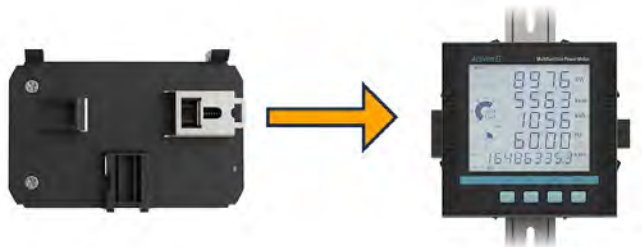

Figure 2-15 - Vertical DIN rail installation

## Acuvim II Series Power Meter

### 2.3 Wiring

There are four terminal strips at the back of the Acuvim II series meter, they are the voltage input terminal, current input terminal, power supply terminal and the communication port terminal.

The three-phase voltage and current are represented by using 1, 2, and 3 respectively. These numbers have the same meaning as A, B, and C used in other literature.

#### 2.3.1 Power Requirement

##### Control Power

There are two options for the control power in the Acuvim II series meter:

1. Standard: 100~415Vac (50/60Hz) or 100-300Vdc
2. Low Voltage DC Option: 20-60Vdc

The two options must be chosen according to the application. Please see the ordering information in the appendix for further information.



**NOTE:** Ensure that the control power terminal of the meter ground is connected to the safety earth of the switch gear.

The meter typically has a low power consumption and can be supplied by an independent source or by the measured load. A regulator or an uninterruptible power supply (UPS) should be used under high power fluctuation conditions. Terminals for the control power supply are 11, 12, and 13 (L, N, and Ground). A switch or circuit breaker shall be included in a building installation. It shall be in close proximity to the equipment, within easy reach of the operator, and shall be marked as the disconnection device for the equipment.

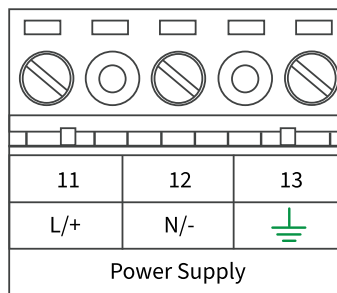

Figure 2-16 - Power Supply Terminal Strip

Choice of wire for the power supply is AWG22-16 or 0.6-1.5mm<sup>2</sup>. Typically, a 1A/250Vac fuse should be used in the auxiliary power supply loop. Terminal 13 must be connected to the ground

terminal of the switch gear. An isolated transformer or EMC filter should be used in the power supply loop if there is a power quality issue with the power supply.

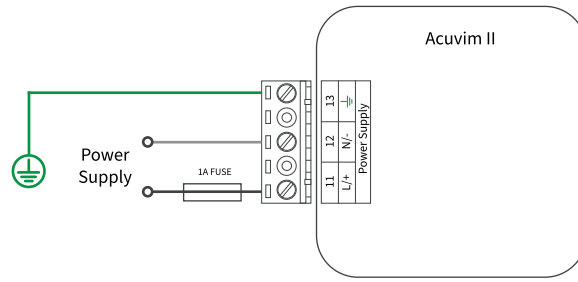

Figure 2-17 - Power Supply

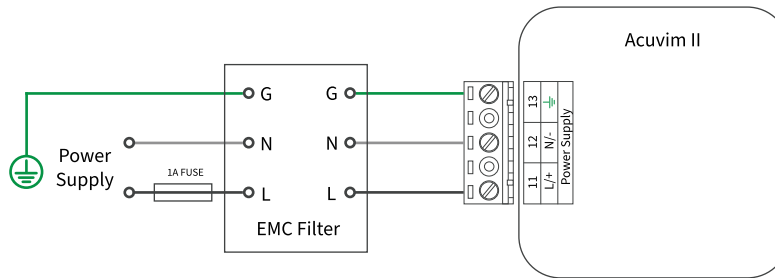

Figure 2-18 - Power Supply with EMC Filter

### 2.3.2 Voltage Input Wiring

#### Voltage Input Terminal

The voltage input terminal strip consists of 4 input terminals: V1 (7), V2 (8), V3 (9), and VN (10).

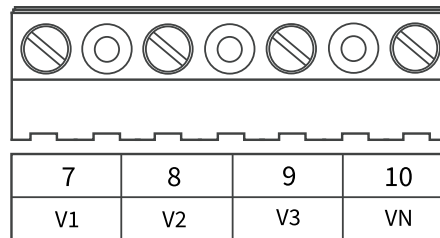

Figure 2-19 - Voltage Input

## Acuvm II Series Power Meter

The maximum voltage input for the Acuvm II series meter shall not exceed 400LN/690LL Vac RMS for three-phase or 400LN Vac RMS for single-phase.

In high voltage systems a Potential Transformer (PT) must be used. The typical secondary output for PTs shall be over 100V or 120V. Ensure to select an appropriate PT to maintain the measurement accuracy of the meter. When connecting using the wye configuration wiring method, the PTs primary side rated voltage should be equal to or close to the phase voltage of the system in order to utilize the full range of the PT. When connecting using the delta configuration wiring method, the PTs primary side rated voltage should be equal to or close to the line voltage of the system. A fuse (typically 1A/250Vac) should be used in the voltage input loop. The wire for voltage input is AWG16-12 or 1.3-2.0mm<sup>2</sup>.



**NOTE:** In no circumstance should the secondary of the PT be shorted. The secondary of the PT should be grounded at one end. Please refer to the wiring diagram section for further details.

### Voltage Input Wiring Methods

#### 3-Phase 4-Wire Wye Mode (3LN)

3-Phase 4-Wire wye mode is commonly used in low voltage electric distribution systems. For voltages lower than 400LN/690LL, the voltage lines can be connected directly to the meters voltage input terminal as shown in Figure 2-20a.

For high voltage systems (over 400LN/690LL), PTs (Potential Transformers) are required as shown in Figure 2-20b.

For both scenarios the meter should be set to 3LN.

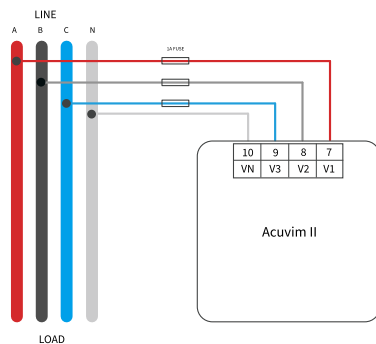

Figure 2-20a - 3LN Direct Connection

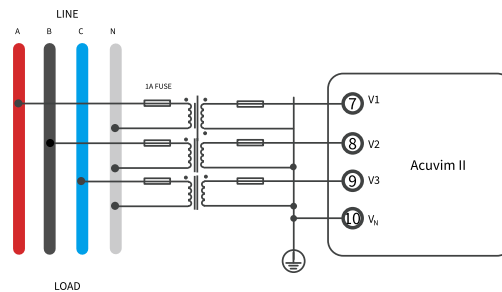

Figure 2-20b - 3LN with 3PTs

### 3-Phase 3-Wire Delta Mode (3LL)

3-Phase 3-Wire Delta mode is commonly used in low voltage electric distribution systems. For voltages lower than 400LN/690LL, the voltage lines can be connected directly to the meters voltage input terminal as shown in Figure 2-20c.

For high voltage systems (over 400LN/690LL), PTs (Potential Transformers) are required as shown in Figure 2-20d.

For both scenarios the meter should be set to 3LL. Common system voltage for 3-phase delta systems are 480V.

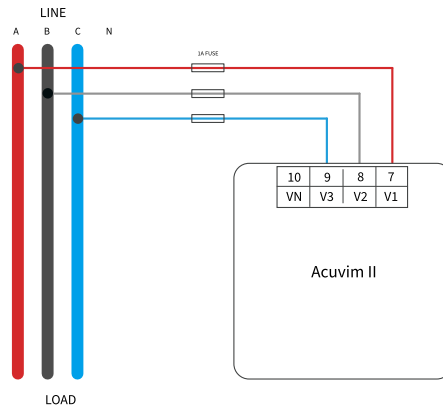

Figure 2-20c - 3LL Direct Connection

### 3-Phase 3-Wire Open-Phase Delta (2LL)

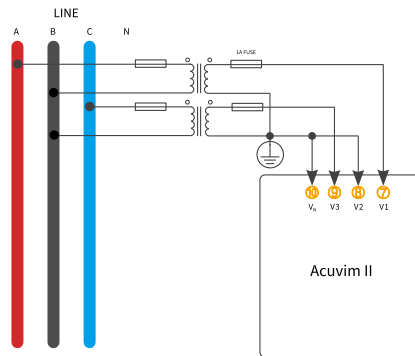

Figure 2-20d - 2LL with 2PTs

## Acuvm II Series Power Meter

### 2-Phase 3-Wire Split Phase (1LL)

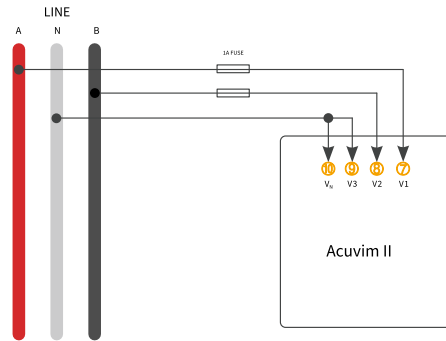

Figure 2-20e - 1LL Direct Connection

### 1-Phase 1-Wire Single Phase (1LN)

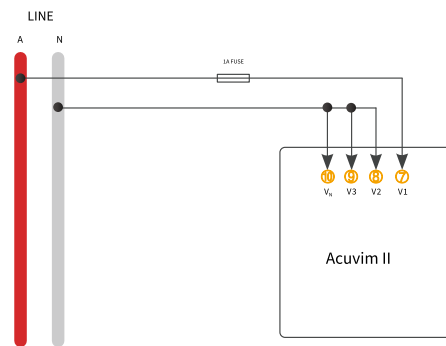

Figure 2-20f - 1LN Direct Connection

### V<sub>n</sub> Connection

V<sub>n</sub> is the reference point of the Acuvm II series meter voltage input. Low wire resistance helps improve the measurement accuracy. Different system wiring modes require V<sub>n</sub> connection methods. Please refer to the wire diagram section for more details.

### 2.3.3 Current Input Wiring

#### Current Input Terminal

Current Transformers (CTs) are required for most engineering applications. Typical current rating for the secondary side of the CT shall be 5A (standard) or 1A (optional); please refer to the ordering information appendix for further details. CTs must be used if the system's rated current is over 5A. The recommended accuracy of the CT should be better than 0.5% with a rating over 3VA to preserve the meter's accuracy. The wire between the CT and the meter shall be as short as possible. The length of the wire effects measurement accuracy.

The wire size of the current input is AWG15-10 or 1.5-2.5mm<sup>2</sup>.

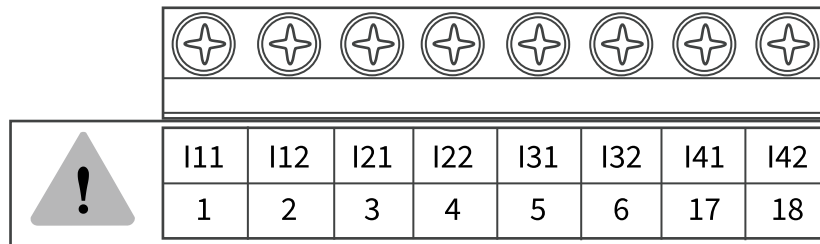

Figure 2-21 - Current Input Terminal

On the current input terminal of the Acuvim II, there are 8 current input channels for 4 CTs.

- Terminal 1 (I11) and 2 (I12) are for the phase A current transformer, where the positive lead of the CT is terminated to I11 and the negative lead is terminated to I12.
- Terminal 3 (I21) and 4 (I22) are for the phase B current transformer, where the positive lead of the CT is terminated to I21 and the negative lead is terminated to I22.
- Terminal 5 (I31) and 6 (I32) are for the phase C current transformer, where the positive lead of the CT is terminated to I31 and the negative lead is terminated to I32.
- Terminal 17 (I41) and 18 (I42) are for the neutral current transformer, where the positive lead of the CT is terminated to I41 and the negative lead is terminated to I42.

**NOTE:** The secondary side of the CT should not be open circuit in any circumstance when the power is on. There should not be any fuse or switch in the CT loop. One end of the CT loop should be connected to ground if using 5A/1A Current Transformers. If using 333mV/mA/Rogowski coil current transformers a ground connection is not required..

## Acuvim II Series Power Meter

### 3CT

The 3CT current wiring configuration can be used when either 3CTs are connected (as shown in Figure 2-22) or when 2 CTs are connected (as shown in Figure 2-23). In either case, there is current flowing through all three circuit terminals.

For any RCT/mV/mA CT, do NOT ground the CTs. The figures below have the current input wiring for both 5A/1A CTs as well as RCT/mV/mA CTs.

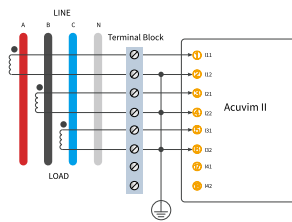

Figure 2-22a - 3 CT 5A/1A

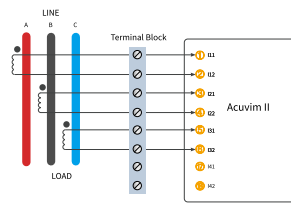

Figure 2-22b - 3 CT 333mV/mA

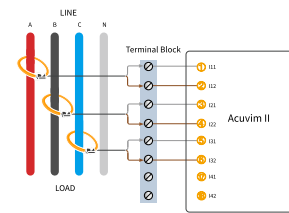

Figure 2-22c - 3CT Rogowski Coil (RCT)

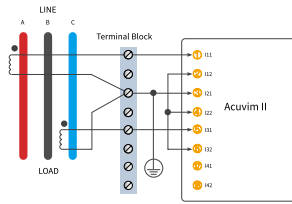

Figure 2-23a - 3CT wiring for 5A/1A CTs with 2CT in open-phase delta systems

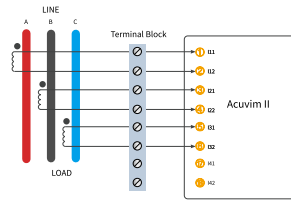

Figure 2-23b - 3CT wiring for 333mV/mA CTs in open-phase delta systems

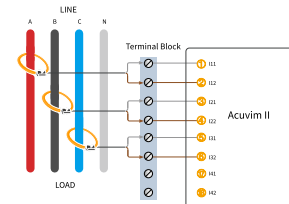

Figure 2-23c - 3CT wiring for Rogowski Coil (RCT) in open-phase delta systems

### 2 CT

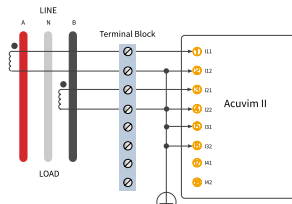

Figure 2-24a - 2CT wiring for 5A/1A CTs in 1LL split-phase systems

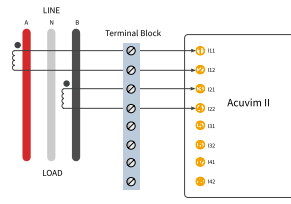

Figure 2-24b - 2CT wiring for 333mV/mA CTs in 1LL split-phase systems

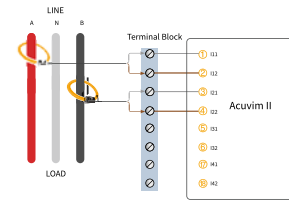

Figure 2-24c - 2CT wiring for Rogowski Coil (RCT) in 1LL split-phase systems

1 CT

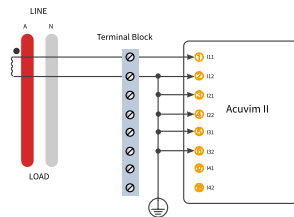

Figure 2-25a - 1CT wiring for 5A/1A CTs in 1LN single phase systems

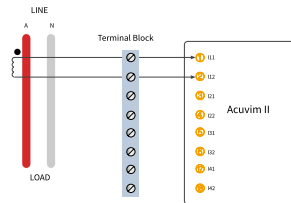

Figure 2-25b - 1CT wiring for 333mV/mA CTs in 1LN single phase systems

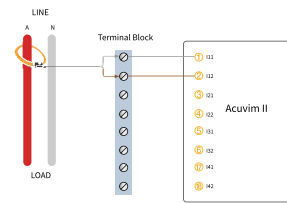

Figure 2-25c - 1CT wiring for Rogowski Coil (RCT) in 1LN single phase systems

2.3.4 Typical Wiring

Wiring Modes

This meter can satisfy almost any kind of three-phase wiring scenario. Please read this section carefully before choosing the suitable wiring method for your power system.

Voltage and current input wiring mode can be set separately in the meters parameter settings:

- The voltage wiring mode can be set as 3-phase 4-line Wye (3LN), 3-phase 3-line direct connection (3LL), 3-phase 3-line open delta (2LL), single phase 2-line(1LN), and single phase 3-line(1LL).
- The current input wiring mode can be set as 3CT, 2CT, and 1CT. The voltage mode can be grouped with the current mode as 3LN-3CT (3CT or 2CT, 3LL-3CT, 2LL-3CT, 2LL-2CT, 1LL-2CT, 1LN-1CT).

### 2.3.5 Frequently Used Wiring Methods

In this section, the most common voltage and current wiring combinations are shown in different diagrams. In order to display measurement readings correctly, please select the appropriate wiring diagram for your setup and application.

#### Typical Wiring Diagrams

##### 1. 3LN-3CT with 3 CTs

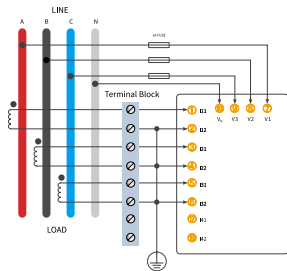

Figure 2-26a 3LN-3CT wiring using 5A/1A CTs

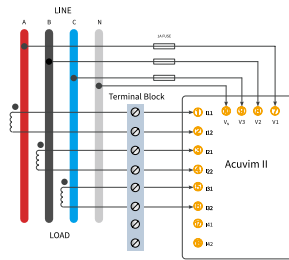

Figure 2-26b 3LN-3CT wiring using RCT/333mV/mA CTs

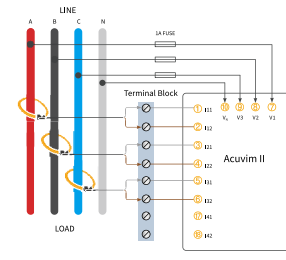

Figure 2-26c 3LN-3CT wiring using Rogowski Coils

##### 2. 3LN-3CT using PTs

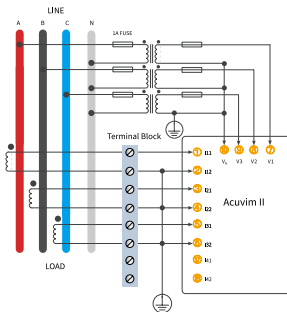

Figure 2-27a 3LN-3CT configuration with PTs using 5A/1A CTs

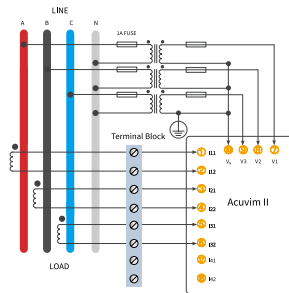

Figure 2-27b 3LN-3CT configuration with PTs using 333mV/mA CTs

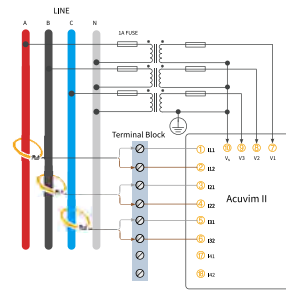

Figure 2-27c 3LN-3CT configuration with PTs using Rogowski Coils

3. 3LL-3CT

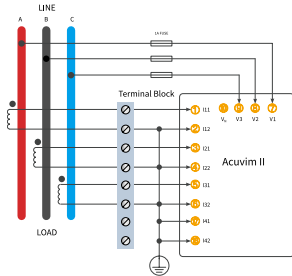

Figure 2-28a 3LL-3CT configuration using 5A/1A CTs

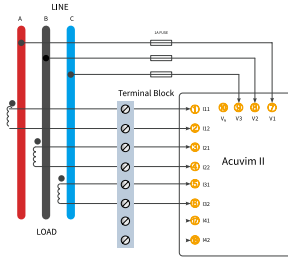

Figure 2-28b 3LL-3CT configuration using 333mV/mA CTs

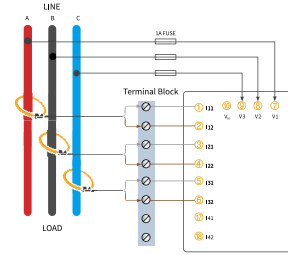

Figure 2-28c 3LL-3CT configuration using Rogowski Coils

4. 2LL-3CT

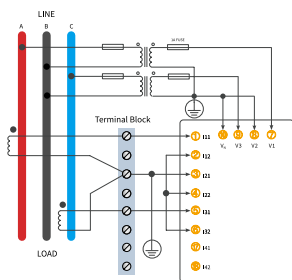

Figure 2-29a 2LL-3CT wiring with PTs using 5A/1A CTs

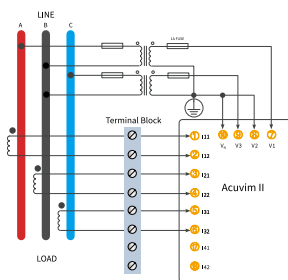

Figure 2-29b 2LL-3CT wiring with PTs using 333mV/mA CTs

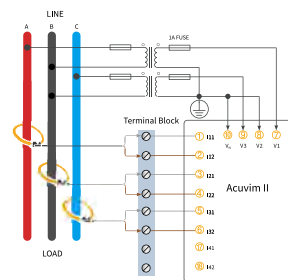

Figure 2-29c 2LL-3CT wiring with PTs using Rogowski Coils

5. 1LN-1CT

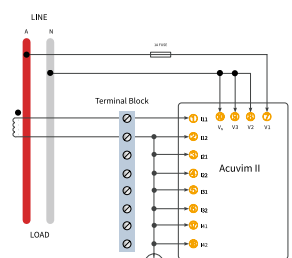

Figure 2-30a 1LN-1CT configuration using 5A/1A CTs

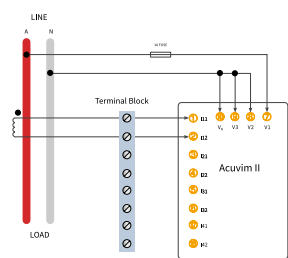

Figure 2-30b 1LN-1CT configuration using 333mV/mA CTs

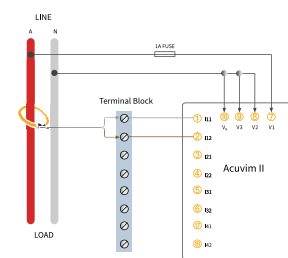

Figure 2-30c 1LN-1CT configuration using Rogowski Coils

6. 1LL-2CT

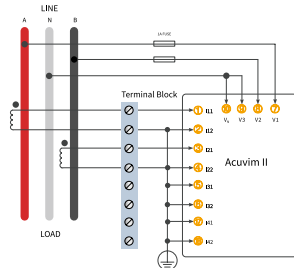

Figure 2-31a 1LL-2CT configuration using 5A/1A CTs

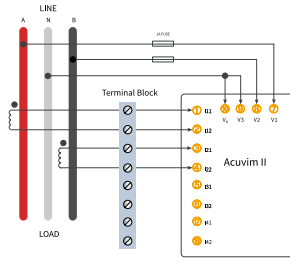

Figure 2-31b 1LL-2CT configuration using 333mV/mA CTs

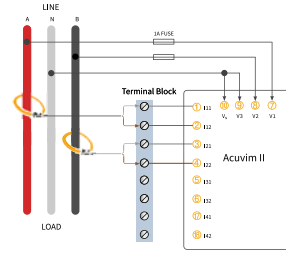

Figure 2-31c 1LL-2CT configuration using Rogowski Coils

2.3.6 Communication

The Acuvim II series meter uses RS485 serial communication and the Modbus RTU protocol. The terminals of communication are A, B, and S (14,15,16).

- **A** is the positive differential signal
- **B** is the negative differential signal
- **S** is connected to the shield of the twisted pair cables

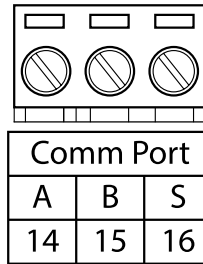

Figure 2-32 Communication Port

Figure 2-33 shows the wiring of the RS485-USB converter to the meter’s communication port terminals. There can be a maximum of 32 devices that can be connected on a RS485 bus.

For the wiring, use a good quality, shielded twisted pair cable, AWG22 (0.5mm<sup>2</sup>) or higher. The overall length of the RS485 cable connecting all devices should not exceed 1200m (4000ft).

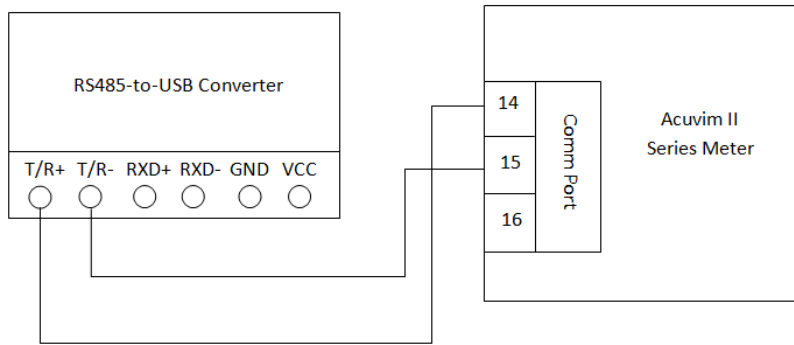

Figure 2-33 RS485-USB connection to Acuvim II series meter

The Acuvim II series meter is used as the slave device of masters such as a PC, PLC, Data Collector or RTU. If the master does not have a RS485 communication port, a converter (such as a RS232/RS485 or a USB/RS485 converter) will be required. Typical RS485 network topologies includes line, circle, and star (wye). The shield of each segment of the RS485 cable must be connected to the ground at one end only.

Every A(+) should be connected to A(+), B(-) to B(-), or it will influence the network, or even damage the communication interface.

The connection topology should avoid "T" type topology, meaning there is a new branch and it does not begin at the beginning point.

Keep communication cables away from sources of electrical noise whenever possible.

When using long communication cables to connect several devices, an anti reflecting resistor (typical value 120Ω-300Ω/0.25W) is normally added to the end of the cable beside the last meter if the communication quality is distorted.

Use RS232/RS485 or a USB/RS485 converter with an optical isolated output and surge protection.

## Chapter 3: Meter Display & Parameter Settings

This chapter describes how to view real time metering data and setting parameters using different key combinations on the meter.

### 3.1 Display Panel and Keys

The front of the Acuvim II series meter consists of an LCD screen and four control keys. All the display segments are illustrated in Figure 3-1. Users should note that all the segments will not display in a single page under normal conditions.

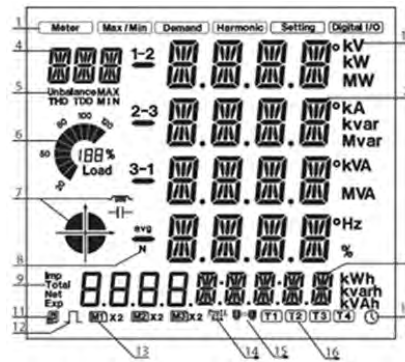











Figure 3-1 All display segments

The icons displayed in figure 3-1 can be explained in the following table:

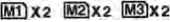



Table 3-1 All display segments

| SN | Display  | Description   |
|----|--|---|
| 1  | Display Mode                                     | Shows different modes on the display area.<br><i>Meter</i> : real-time measurement<br><i>Max/Min</i> : Statistical data<br><i>Demand</i> : Power demand data<br><i>Harmonic</i> : Harmonic data<br><i>Setting</i> : Parameter/meter settings<br><i>Digital I/O</i> : Viewing I/O module data. |
| 2  | Four lines of "0000" digits in the metering area | The numeric metering data will be displayed here.   |
| 3  | Four "0000" and five "00000" digits              | Display energy data and real-time clock. Also used for the setting mode and digital I/O mode display.   |

### Chapter 3: Meter Display & Parameter Settings

| SN | Display   | Description   |
|----|---|---|
| 4  | Three "8" digits   | Item Icons:<br><i>U</i> for voltage<br><i>I</i> for current<br><i>P</i> for active power<br><i>Q</i> for reactive power<br><i>S</i> for apparent power<br><i>PF</i> for power factor<br><i>F</i> for frequency<br> for phase angles<br><i>DMD</i> for demand<br><i>Mxx</i> for expanded I/O module type and display setting page number. |
| 5  | Unbalance, THD, TDD, MAX, MIN   | Item Icons: <i>Unbalance</i> for unbalance of the voltage and current; <i>THD</i> for total harmonics distortion; <i>TDD</i> for total demand distortion; <i>MAX</i> for maximum and <i>MIN</i> for minimum.  |
| 6  | Load Rate    | Displays the percentage of load to the rated current or power.  |
| 7  | Four Quadrant Icon: <br>Load Type Icon:   |  : Quadrant of the system power<br> : Inductive Load<br> : Capacitive Load  |
| 8  | 1-2, 2-3, 3-1, avg, N   | <i>1, 2, 3</i> : Represents 3 phases <i>A, B, C</i><br><i>1-2, 2-3, 3-1</i> : Represents 3 phase line to line <i>AB, BC, CA</i><br><i>avg</i> : Represents the average<br><i>N</i> : stands for neutral   |
| 9  | Energy icon: Imp, Total, Net, Exp   | <i>Imp</i> : Import Energy<br><i>Total</i> : Absolute sum of Import and Export energy<br><i>Net</i> : Algebraic sum of Import and Export energy<br><i>Exp</i> : Export Energy   |
| 10 | Units Measured  | Voltage: <i>V, kV</i><br>Current: <i>A, kA</i><br>Active Power: <i>kW, MW</i><br>Reactive Power: <i>kvar, Mvar</i><br>Apparent Power: <i>kVA, MVA</i><br>Frequency: <i>Hz</i><br>Active Energy: <i>kWh</i><br>Reactive Energy: <i>kvarh</i><br>Apparent Energy: <i>kVAh</i><br>Percentage: <i>%</i><br>Phase Angle: <i>°</i>  |
| 11 | Communication Icon   | No Icon: no communication<br>One Icon: query sent<br>Two Icons: query sent and response received  |

## Acuvim II Series Power Meter

| SN | Display  | Description   |
|----|--|---|
| 12 | Energy pulse output indicator     | No Icon: no pulse output<br>With Icon: icon blinks when sending pulse output  |
| 13 | Expanded I/O module indicator<br> | <i>M1</i> : one AXM-IO1 connected<br><i>M1x2</i> : two AXM-IO1 connected<br><i>None</i> : no AXM-IO1 connected<br><i>M2</i> : one AXM-IO2 connected<br><i>M2x2</i> : two AXM-IO2 connected<br><i>None</i> : no AXM-IO2 connected<br><i>M3</i> : one AXM-IO3 connected<br><i>M3x2</i> : two AXM-IO3 connected<br><i>None</i> : no AXM-IO3 connected                                  |
| 14 | Profibus Module Indicator         | Icon: Profibus module connected<br>No Icon: Profibus module not connected   |
| 15 | Ethernet Module Indicator<br>     | No Icon: Ethernet module not connected<br>With Icon: Ethernet module connected when the Second Communication Protocol is set as Other, Wi-Fi module connected when the Second Communication Protocol is set to Wi-Fi, BACnet module connected when the Second Communication Protocol is set to BACnet, Mesh module connected when the Second Communication Protocol is set to Mesh. |
| 16 |                                 | Current Tariff  |
| 17 | Time Icon                       | Time Display  |

There are four keys on the front panel of the meter, labeled **H**, **P**, **E**, **V/A** from left to right. These four keys are used to read the real-time metering data, set parameters, and navigate the meter.

### 3.2 Metering Data

To view the metering data, press **H** and **V/A** simultaneously for about one second then release; this will activate the display mode selection and the cursor will begin flashing. Press **P** or **E** to move the flashing cursor right or left. To enter the metering mode, move the cursor to **Meter** then press **V/A**. In the metering mode, the meter displays measurements such as voltage, current, power, power factor, phase angle, unbalance, etc.

#### 3.2.1 Voltage and Current Data

To view the voltage and current, press **V/A** while in metering mode.

The screen will roll to the next page when **V/A** is pressed again. It will go back to the first screen if you press **V/A** at the last screen. The following figure shows the screen sequence:

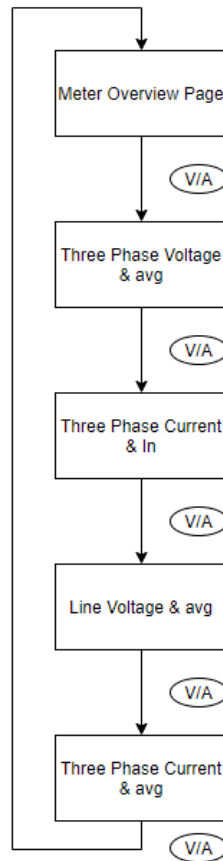

Figure 3-2 - Voltage and Current screen sequence

**NOTE:** When the meter is set to 2LL or 3LL, there is no phase voltage or neutral current displayed. Therefore, only the third screen (line voltage & avg) and the fourth screen (three-phase current & avg) will be displayed. When the meter is set to 1LN, only phase A voltage and phase A current will be displayed; no other screens will be displayed. When the meter is set to 1LL, no phase C voltage or phase C current will be displayed.

## Acuvim II Series Power Meter

Figure 3-3 shows an image of the three-phase voltage reading, where **1** represents phase A, **2** represents phase B, **3** represents phase C, and **avg** represents the average phase voltage.

Similarly in Figure 3-4, the three-phase current and average can be seen in the same representation.



Figure 3-3 - Three-Phase Voltage Page

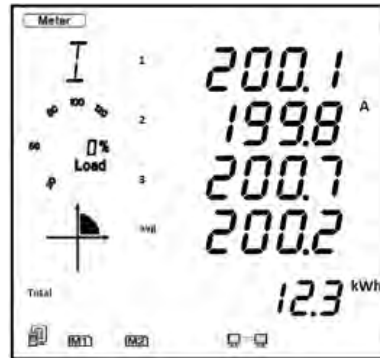

Figure 3-4 - Three-Phase Current Page

In the voltage and current screen sequence the very first page provides users with an overall summary of the metering values for the Acuvim II meter. Figure 3-5 shows the main summary page of the Acuvim II where the top line of data refers to the average line-to-line voltage, the second refers to the total power of the system, the third line refers to the average current, the fourth line refers to the total system power factor, and the very last line refers to the total energy.

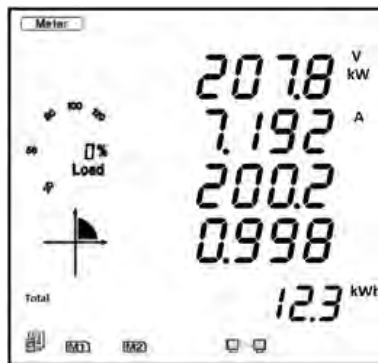

Figure 3-5 Meter Summary Page

### 3.2.2 Power, Power Factor, and Frequency

To view all power related data, press **P** while in metering mode.

The screen will roll to the next page when **P** is pressed again. It will go back to the first screen if you press **P** at the last screen. The following figure shows the screen sequence:

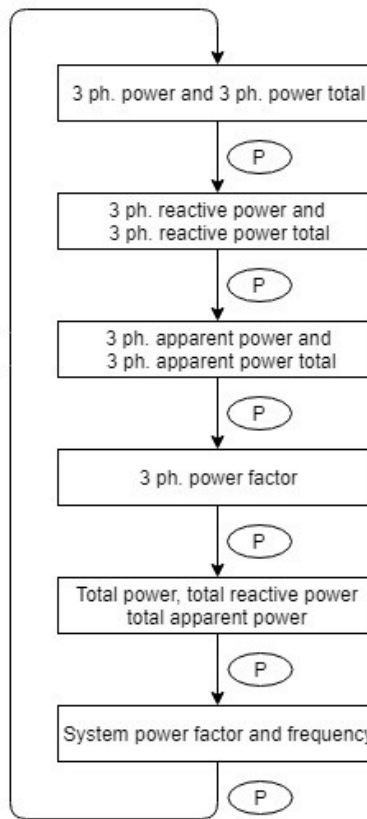

Figure 3-6 - Power, Power Factor, and Frequency screen sequence

**NOTE:** When the meter is set to 2LL or 3LL, only the fifth screen (system power) and the sixth screen (system power factor & frequency) will be displayed. When the meter is set to 1LN only phase A power and phase A power factor will be displayed. When the meter is set to 1LL, no phase C power and phase C power factor will be displayed.



Figure 3-7 - Three-Phase Power Page



Figure 3-8 - Total System Power Page

### 3.2.3 Phase Angles and Unbalance

To view the phase angle and unbalance data, press **H** while in metering mode.

The screen will roll to the next page when **H** is pressed again. It will go back to the first screen if you press **H** on the last screen. The following figure shows the screen sequence:

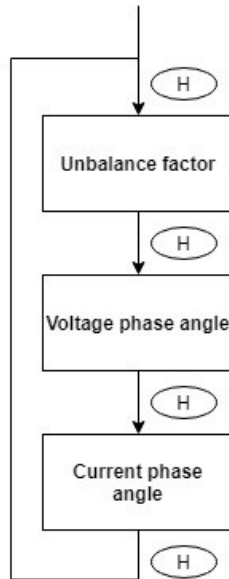

Figure 3-9 - Phase Angle and Unbalance screen sequence

**NOTE:** When using 2LL or 3LL wiring modes, the voltage here stands for line-to-line voltage. Otherwise, the voltage stands for line-to-neutral voltage. When the meter is set to 1LN, only phase A current to phase A voltage angle will be displayed. When the meter is set to 1LL, no phase C voltage or current to phase A voltage angle will be displayed.



Figure 3-10 - Voltage Phase Angle Page



Figure 3-11 Current Phase Angle Page

### 3.2.4 Energy

To view the energy and real time clock on the meter, press the **E** button. The screen will roll to the next page when **E** is pressed again. It will go back to the first screen if you press **E** at the last screen.

The Acuim II series meter can be set to record either primary or secondary energy. The unit of energy is kWh for active energy, kvarh for reactive energy, and kVAh for apparent energy. The running time has a resolution of 0.01h. The meter begins accumulating time when it is initially powered up. The accumulated time is stored in the non-volatile memory and can be reset via communication or from the meter's display.

The energy reading on the Acuim II meter can be read at the bottom of the display, where users can cycle between different types of energy on any metering page on the meter except for the Meter Summary page. The metering summary page only displays the total energy (kWh). The following flow chart shows the screen sequence for the energy readings.

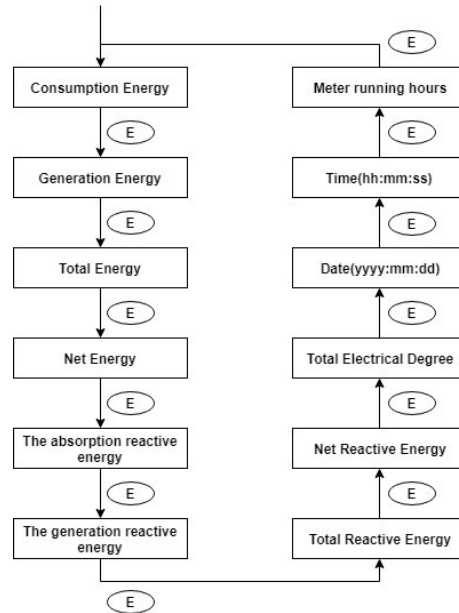

Figure 3-12 - Energy and Real Time Clock screen sequence

There are different types of energy that the Acuvim II meter can measure, Figure 3-13 shows the Import Active Energy represented by the **IMP** icon and the **kWh** unit.



Figure 3-13 - Import Active Energy

Table 3-2 shows the different icons and units for all the energy measurements in the Acuvim II meter.

Table 3-2 Energy Parameter Table

| SN    | Parameter              | Unit  |
|-------|------------------------|-------|
| Imp   | Import Energy          | kWh   |
| Exp   | Export Energy          | kWh   |
| Net   | Net Energy             | kWh   |
| Total | Total Energy           | kWh   |
| Imp   | Import Reactive Energy | kvarh |
| Exp   | Export Reactive Energy | kvarh |
| Net   | Net Reactive Energy    | kvarh |
| Total | Total Reactive Energy  | kvarh |
|       | Apparent Energy        | kVAh  |

The meter's time can also be found in the energy screen sequence. Figure 3-14 shows the date displayed on the meter screen. The date is read as YYYY.MM.DD; the figure below shows the date as April 28, 2020. In addition, when viewing the time/date on the meter display, the time icon will be displayed on the bottom right corner of the meter screen.



Figure 3-14 - Time & Date Reading

### 3.2.5 TOU Display

In the metering mode, press **P** and **E** simultaneously to enter the TOU (Time-of-Use) mode. In the TOU mode, the meter displays the energy, maximum demand, and its time in different tariffs.

The screen sequence for the TOU data can be seen in Figure 3-15:

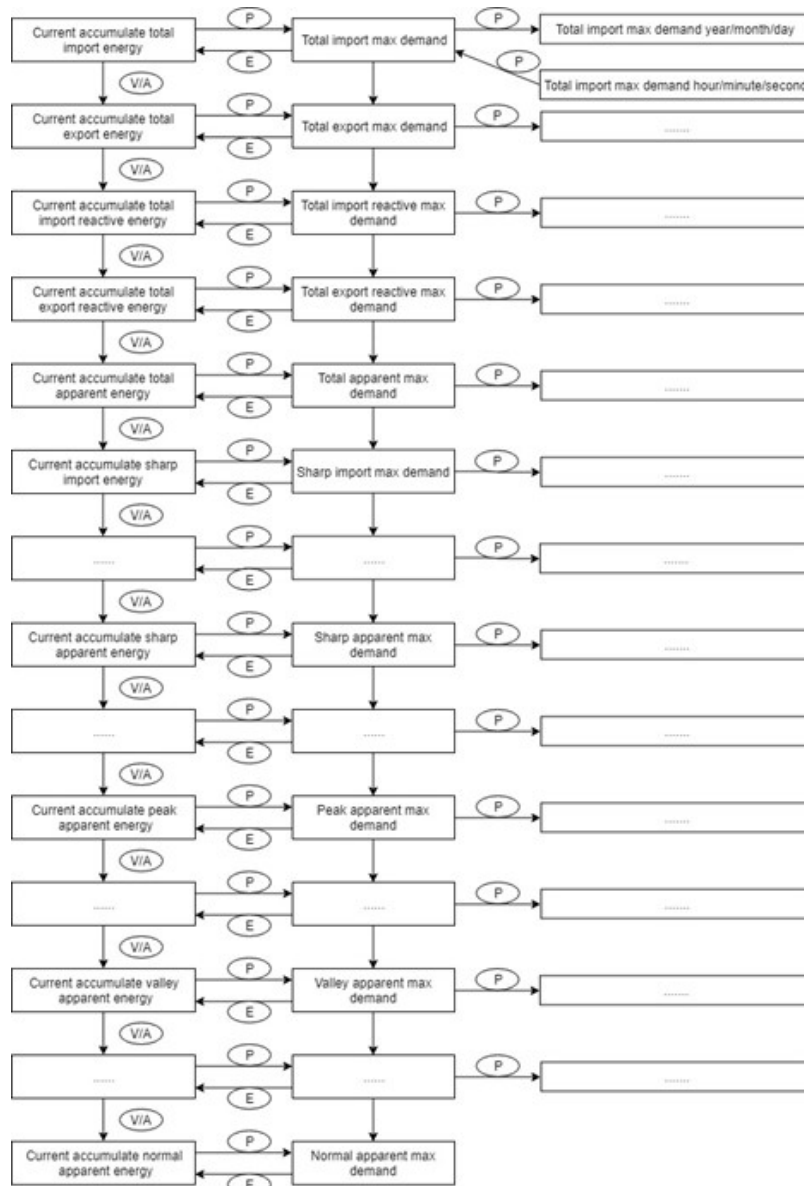

Figure 3-15 - TOU screen sequence

### 3.3 Statistical Data

In the statistical data mode, the meter displays the maximum and minimum values for voltage, current, power, power factor, unbalance, demand, THD, etc. To change the mode of the Acuvim II meter to view statistical data, press **H** and **V/A** simultaneously for about one second then release; the screen will go blank and the cursor will begin flashing. Press either **P** or **E** to move the flashing cursor over to **Max/Min** and press **V/A** to enter and view the statistical data.

When **P** is pressed, the screen will roll to the next page, and will roll back to the first screen when pressed at the last page. When **E** is pressed, the screen will roll back to the previous page, and will roll back to the last screen when pressed at the first page.

Press **V/A** to switch the view between maximum and minimum. For example, if the current display is showing the maximum phase voltage value, then **V/A** is pressed, the display will show the minimum phase voltage value. If **V/A** is pressed again, the display will switch back to show the maximum phase voltage value. The following figure shows the screen sequence:

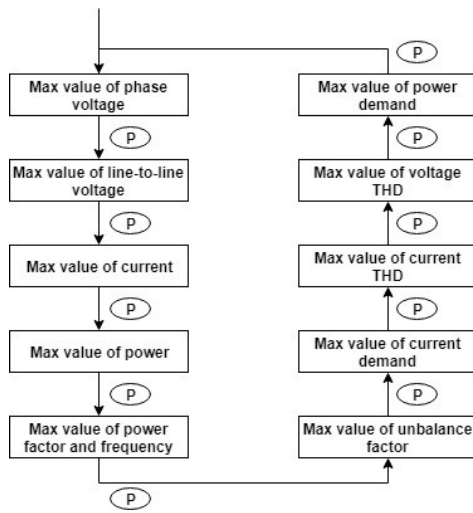

Figure 3-16 - Max/Min screen sequence

**NOTE:** The figure shows the rolling sequence when **P** is pressed. The sequence would be reversed if users press **E** to roll between screens. When the meter is set to 2LL or 3LL, the first screen (max value of phase voltage) will not be displayed. When the meter is set to 1LL, there are no such displays as phase C voltage, Ubc and Uca line voltage, phase C current, three-phase voltage and current unbalance factor, Uc and Ic THD, phase C current demand, etc.

## Acuvim II Series Power Meter

**NOTE:** The timestamp for the max/min parameters can be viewed only from the Acuvim software or through Modbus communication. There are no commands associated with the H button in the Max/Min display mode.

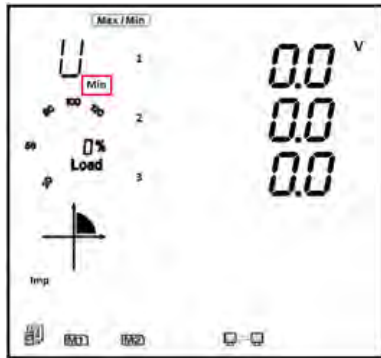

Figure 3-17 Acuvim II Minimum Readings



Figure 3-18 Acuvim II Maximum Readings

### 3.4 Demand Data

To view the demand data, press **H** and **V/A** simultaneously for about one second then release; the screen will go blank and the cursor will begin flashing. Press either **P** or **E** to move the flashing cursor over to **Demand** and press **V/A** to view the meters demand data. The first screen that is shown is the demand of active power, reactive power, and apparent power. Press either **P** or **E** to view the current demand of phase A, phase B, and phase C. The power demand and current demand are the only two screens that can be read in the demand mode.

**NOTE:** When the meter is set to 1LL, there is no phase C current demand displayed. When the meter is set to 1LN, no phase B and C current demand will be displayed.

**NOTE:** There are no commands associated with the V/A and H button in the demand readings page.

Figure 3-19 shows the power demand screen that has a system active power demand of 112.7 kW, system reactive power demand of 0.063 kvar, and a system power demand of 115.1 kVA.



Figure 3-19 Power Demand Screen

### 3.5 Harmonic Data

In the Harmonic data mode, the meter displays the individual harmonic data for voltage and current, Total Harmonic Distortion, odd Harmonic Distortion, even Harmonic Distortion, Crest Factor, and K Factor. To view the Harmonic data, press **H** and **V/A** simultaneously for about one second then release; the screen will go blank the cursor will begin flashing. Press either **P** or **E** to move the flashing cursor over to **Harmonic** and press **V/A** to view the Harmonic data of the meter.

#### 3.5.1 Power Quality Data

While in the Harmonic data mode, press **H** to display the power quality data. By pressing **H** again, the screen will roll to the next page and will roll back to the first screen when **H** is pressed at the last page. Figure 3-20 shows the screen sequence for the power quality parameters.

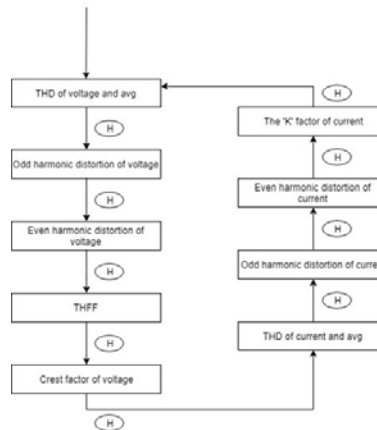

Figure 3-20 - Power Quality Screen Sequence

## Acuvim II Series Power Meter

**NOTE:** When the meter is set to 1LN, only phase A is displayed for voltage THD, voltage odd harmonic distortion, voltage even harmonic distortion, THFF, voltage crest, current THD, current odd harmonic distortion, current even harmonic distortion, and current K factor. When the meter is set to 1LL phase C is not displayed.

Figure 3-21 below shows the Total Harmonic Distortion for Voltage, where Phase A THD is 2.050%, Phase B THD is 1.990%, Phase C THD is 1.920%, and the Average Phase Voltage THD is 1.986%.



Figure 3-21 - Harmonic Distortion Reading

### 3.5.2 Individual Harmonic Data

While in harmonic mode, press **V/A** to switch from the THD parameters to the individual harmonic data display.

In the harmonic data display, the harmonic order will increase by one each time **P** is pressed and will return to the 2nd Harmonic when **P** is pressed at the 63rd harmonic. The harmonic order will decrease by one each time **E** is pressed and will return to the 63rd when **E** is pressed at the 2nd harmonic.

Press **V/A** to switch the display between voltage harmonics and current harmonics.

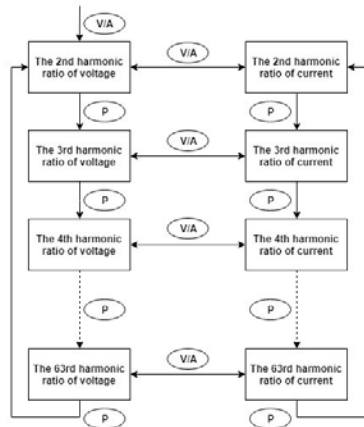

Figure 3-22 - Individual Harmonic data screen sequence

**NOTE:** The figure shows the rolling sequence when pressing P. If the E button is pressed, the sequence will be reversed. When the meter is set to 1LN, only phase A is displayed for voltage and current harmonic magnitudes. When the meter is set to 1LL, phase C is not displayed for voltage and current harmonic magnitudes.

Figure 3-23 shows the 5th order harmonic readings for current: Phase A is 12.35%, Phase B is 4.940%, and Phase C is 7.541%.



Figure 3-23 - Individual Harmonic Reading

### 3.6 Expanded I/O Module Data

To view the data from the expanded I/O modules, press **H** and **V/A** simultaneously for about one second then release; the screen will go blank, and the cursor will begin flashing. Press either **P** or **E** to move the cursor right or left until it is on **Digital I/O**, then press **V/A** to view the I/O data.

In the expanded I/O module data mode, the meter displays the data from the expanded I/O modules such as the DI status, DI pulse counter, relay status, analog input, analog output etc.

In this mode the first page is the module selection. You can choose to view the available modules that are attached to the meter. If no expanded I/O modules are connected, the screen will display **NO IO**.

#### 3.6.1 Module Selection:

In the module selection screen press **P** to move the cursor downwards, the cursor will move to the top when it reaches the bottom. If only one module is connected, pressing **P** will have no effect.

Press **E** to move the cursor upwards, the cursor will move to the bottom when it reaches the top. If only one module is connected, pressing **E** will have no effect.

Press **V/A** to select the module and enter the I/O module data selection mode.

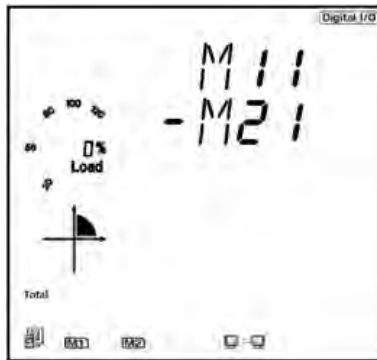

Figure 3-24 - Module Selection Screen

As shown in the figure, two modules are connected, AXM-IO11, AXM-IO21 which are indicated by M11, and M21, respectively. The cursor in the figure points to M21. The following table lists all I/O modules and codes they are associated with.

Table 3-3 I/O Module Representation

| Code | Module    |
|------|-----------|
| M11  | AXM-IO1-1 |
| M12  | AXM-IO1-2 |
| M21  | AXM-IO2-1 |
| M22  | AXM-IO2-2 |
| M31  | AXM-IO3-1 |
| M32  | AXM-IO3-2 |

**I/O Module Data Display**

In the I/O Module Data selection screen, press **P** to move the cursor downwards; the cursor will move to the top when it reaches the bottom. Please note that there are 3 parameters for the AXM-IO1, 3 parameters for the AXM-IO2, and 4 parameters for the AXM-IO3.

Press **E** to move the cursor upwards; the cursor will move to the bottom when it reaches the top.

Press **V/A** to select the parameter and enter the display of the data.

Press **H** to return to the module selection screen.

The following figures display the screen sequence for each I/O module supported on the Acuvim II.

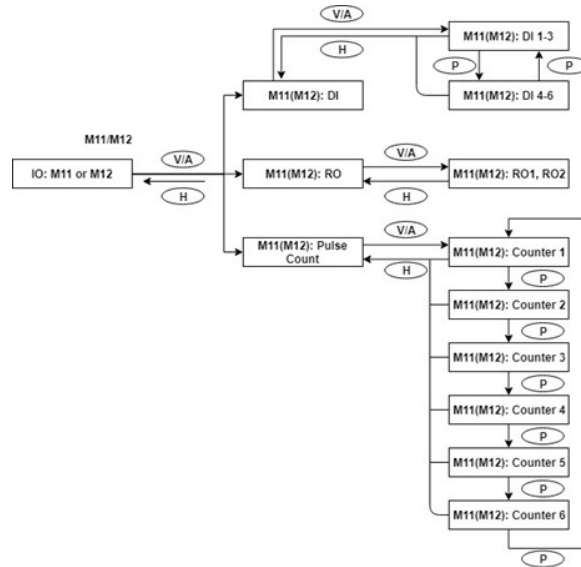

Figure 3-25 - AXM-IO1 data display screen sequence

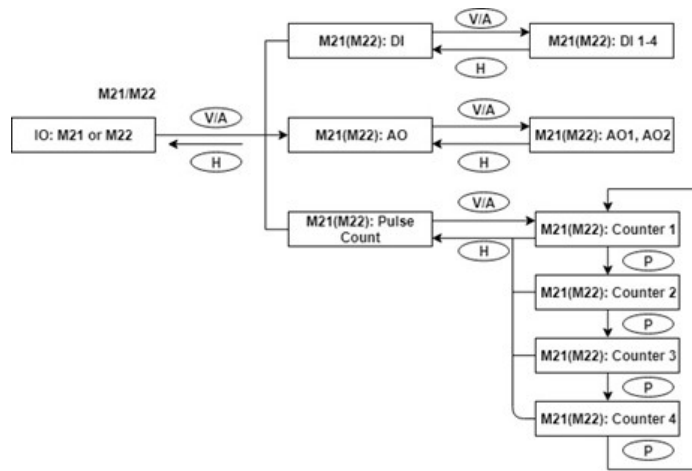

Figure 3-26 - AXM-IO2 data display screen sequence

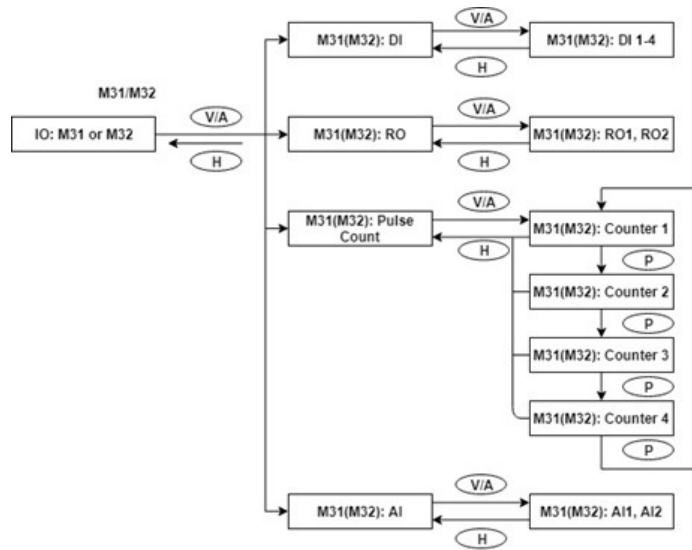

Figure 3-27 - AXM-IO3 data display screen sequence

### 3.7 Meter Setting Mode

In the settings mode, the system parameters, expanded I/O module parameters, alarm parameters, and communications module parameters can be read and modified. To access the settings mode, press **H** and **V/A** simultaneously for about one second then release; the screen will go blank, and the cursor will begin flashing. Press either **P** or **E** to move the flashing cursor over to **Setting** and press **V/A** to enter the meter settings.

#### 3.7.1 Password Inquiry

In order to access the meter's settings, the meter's password must be entered. By default, the meter password is **0000**. The following figure shows the password screen.



Figure 3-28 - Password Inquiry Page

To enter a password:

- Press **H** to move the flashing cursor to the next position.
- Press **P** to increase the number by 1.
- Press **E** to decrease the number by 1.
- Press **V/A** to confirm the password.

**NOTE:** If the meter's password is unknown or forgotten, please contact Accuenergy Technical Support.

#### 3.7.2 Parameter Selection Mode

Once the password has been entered correctly, there are four options to choose from in the parameter selection mode:

- System

## Acuvim II Series Power Meter

- I/O
- NET (Depending on the type of communications module and protocol selected, this may say MESH or BACNET)
- Alarm

To navigate in the parameter selection mode, press **P** to move the cursor downwards; the cursor will move to the top when it reaches the bottom. Press **E** to move the cursor upwards; the cursor will move to the bottom when it reaches the top. Press **V/A** to select and enter the setting.



Figure 3-29 - Parameter Selection Page

### 3.7.3 System Settings

Users can select and modify system parameters in the system parameter setting mode.

#### Key functions for selecting a parameter:

- Pressing **P** will roll to the next screen and will return to the first page when **P** is pressed at the last page.
- The screen will roll to the last page each time **E** is pressed and will return to the last page when **E** is pressed at the first page.
- Press **V/A** to modify the selected parameter.
- Press **H** to return to the parameter selection mode.

#### Key functions for modifying the parameter:

- Press **H** to move the flashing cursor to the next position.
- Press **P** to increase the number by 1.
- Press **E** to decrease the number by 1.
- Press **V/A** to confirm the modification and return to parameter selection mode.

Figure 3-30 - System Parameters page sequence

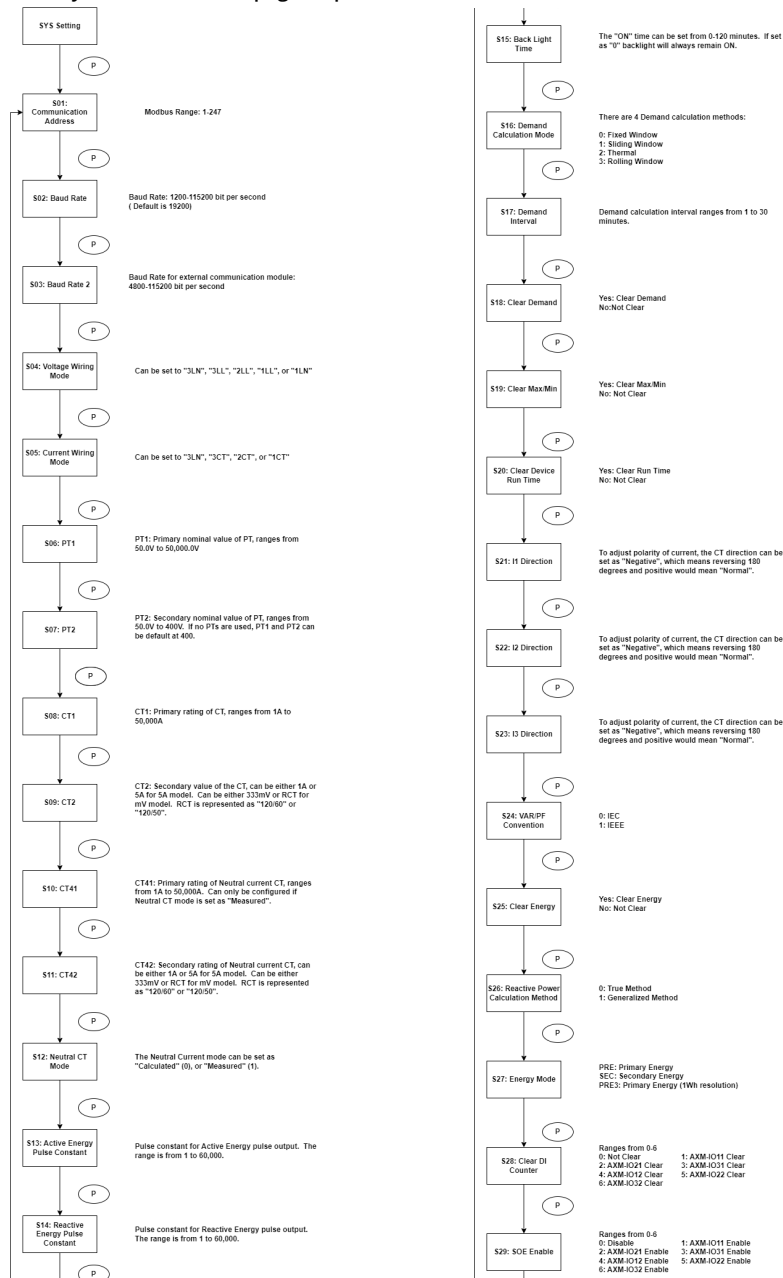

V: 3.0 Revised: November 2022

## Acuvim II Series Power Meter

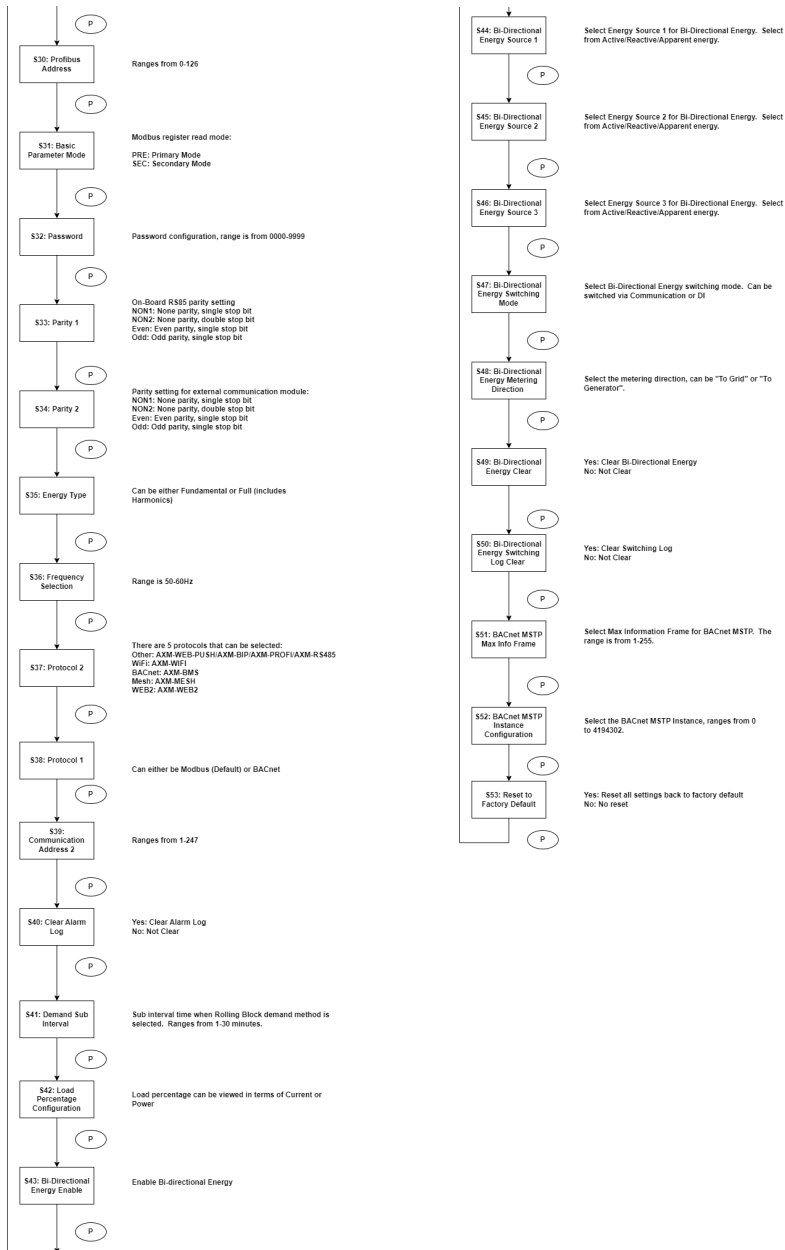

### 3.7.4 I/O Module Settings

In the expanded I/O module parameter mode, users can choose to view the available modules that are attached to the meter and modify their parameters. If no expanded I/O modules are connected, the screen will display **NO IO**. To return to the system parameter setting menu, press **H**.

#### Key functions for I/O module selection:

- Press **H** to return to parameter selection mode.
- Press **P** to move the cursor downwards. The cursor will move to the top when it reaches the bottom. If there is only one module connected, pressing **P** will have no effect.
- Press **E** to move the cursor upwards, the cursor will move to the bottom when it reaches the top. If there is only one module connected, pressing **E** will have no effect.
- Press **V/A** to select the module and enter the I/O module parameter setting mode.

#### Key functions for modifying the parameter:

- Press **H** to move the flashing cursor to the next position.
- Press **P** to increase the number by 1.
- Press **E** to decrease the number by 1.
- Press **V/A** to confirm the modification and return to parameter selection mode.

**NOTE:** Figures 3-30 to 3-33 show the rolling sequence using the P key. If you are using the E key for scrolling across the pages, the sequence will be reversed.

The following figures show the sequence for the I/O module settings:

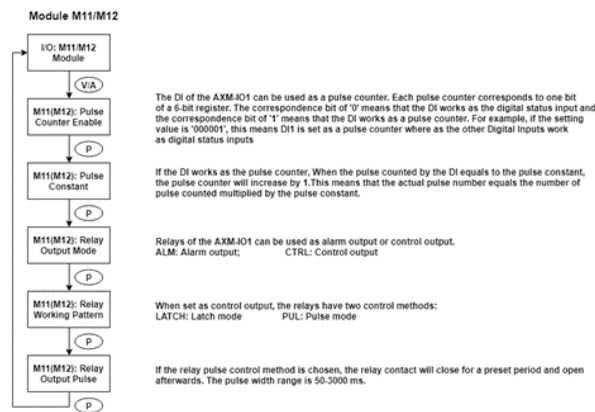

Figure 3-31 - Screen sequence for AXM-IO11/IO12

## Acuvim II Series Power Meter

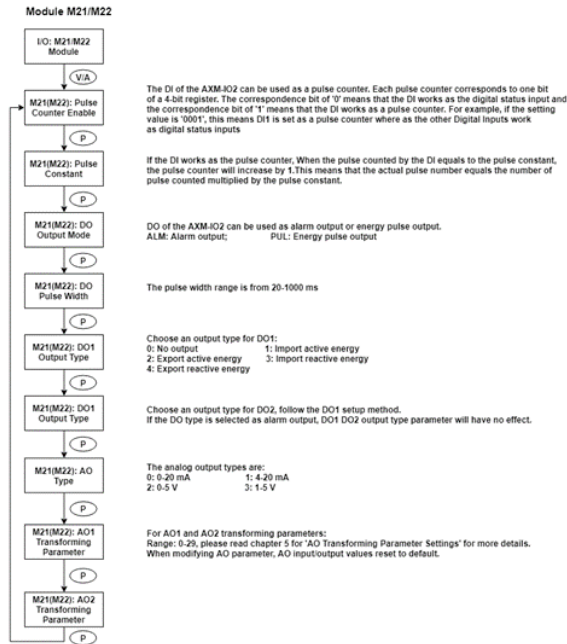

Figure 3-32 - Screen sequence for AXM-IO21/IO22

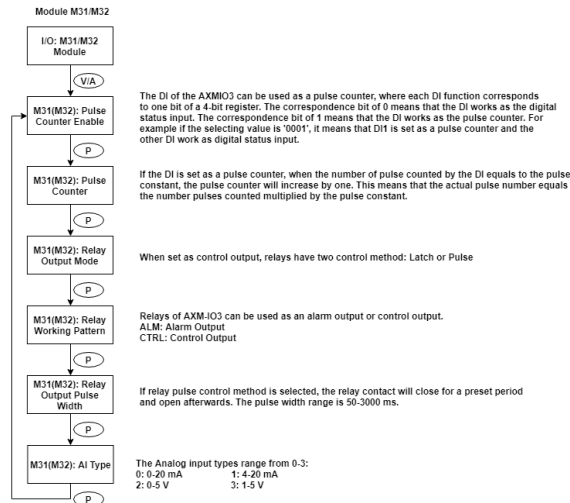

Figure 3-33 - Screen sequence for AXM-IO31/IO32

### 3.7.5 Communications Module Settings

When the second communication protocol is set to **BACnet**, there are certain pages that will be displayed related to BACnet. These pages will only be shown when the module is successfully connected to the meter; if the meter does not detect any module, it will display a **LOADING** page.

When the second communication protocol is set to **MESH**, the meter will display parameters related to the AXM-MESH module.

When the second communication protocol is set to **OTHER**, there will be parameters displayed related to the AXM-WEB-PUSH module.

When the second communication protocol is set to **WIFI**, there will be parameters displayed related to the AXM-WIFI module.

When the second communication protocol is set to **WEB2**, there will be parameters displayed related to the AXM-WEB2 module.

#### Key functions for finding the IO module parameters:

- Press **H** to return to parameter selection mode.
- The screen will roll to the next page each time **P** is pressed and will return to the first page when **P** is pressed on the last page.
- The screen will roll to the last page each time **E** is pressed and will return to the last page when **E** is pressed at the first page.
- Press **V/A** to modify the selected parameter.

#### Key functions for modifying the module parameters:

- Press **H** to move the flashing cursor to the next position.
- Press **P** to increase the number by 1.
- Press **E** to decrease the number by 1.
- Press **V/A** to confirm the modification and return to parameter selection mode.

## Acuvim II Series Power Meter

The following figures show the screen sequence for the supported communication protocols:

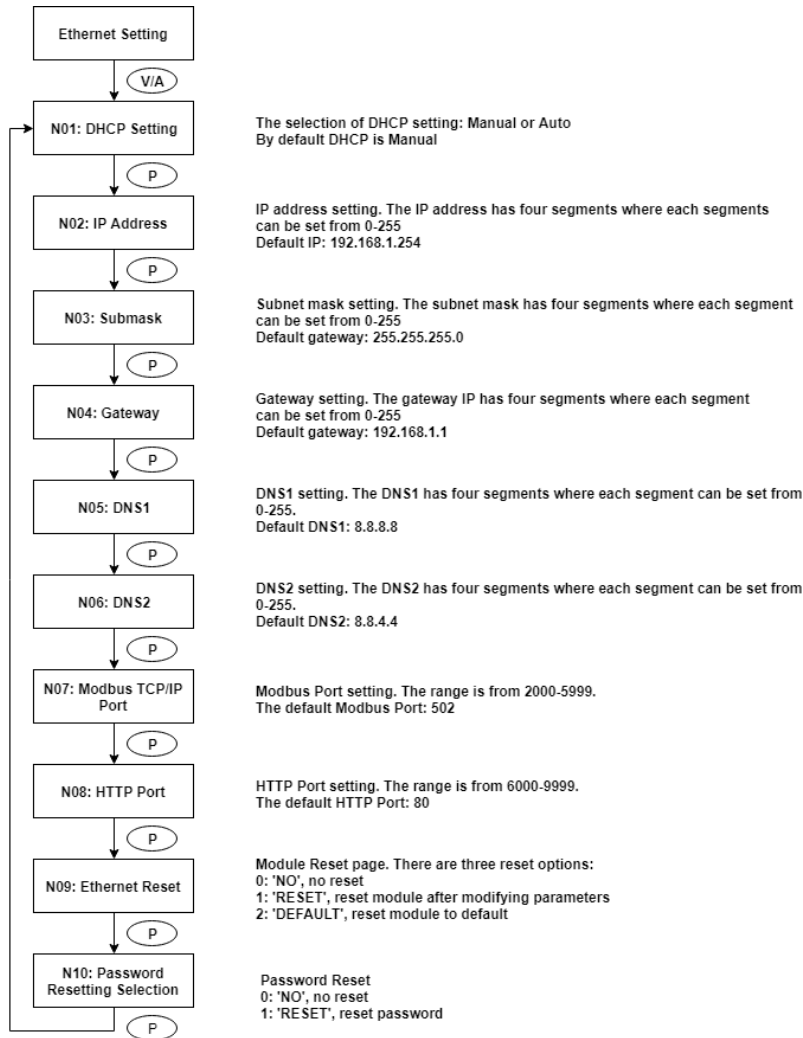

Figure 3-34 - Ethernet module net settings screen sequence

**NOTE:** This figure shows the rolling screen sequence using the P key. If using the E key for rolling to the next page the sequence will be reversed.

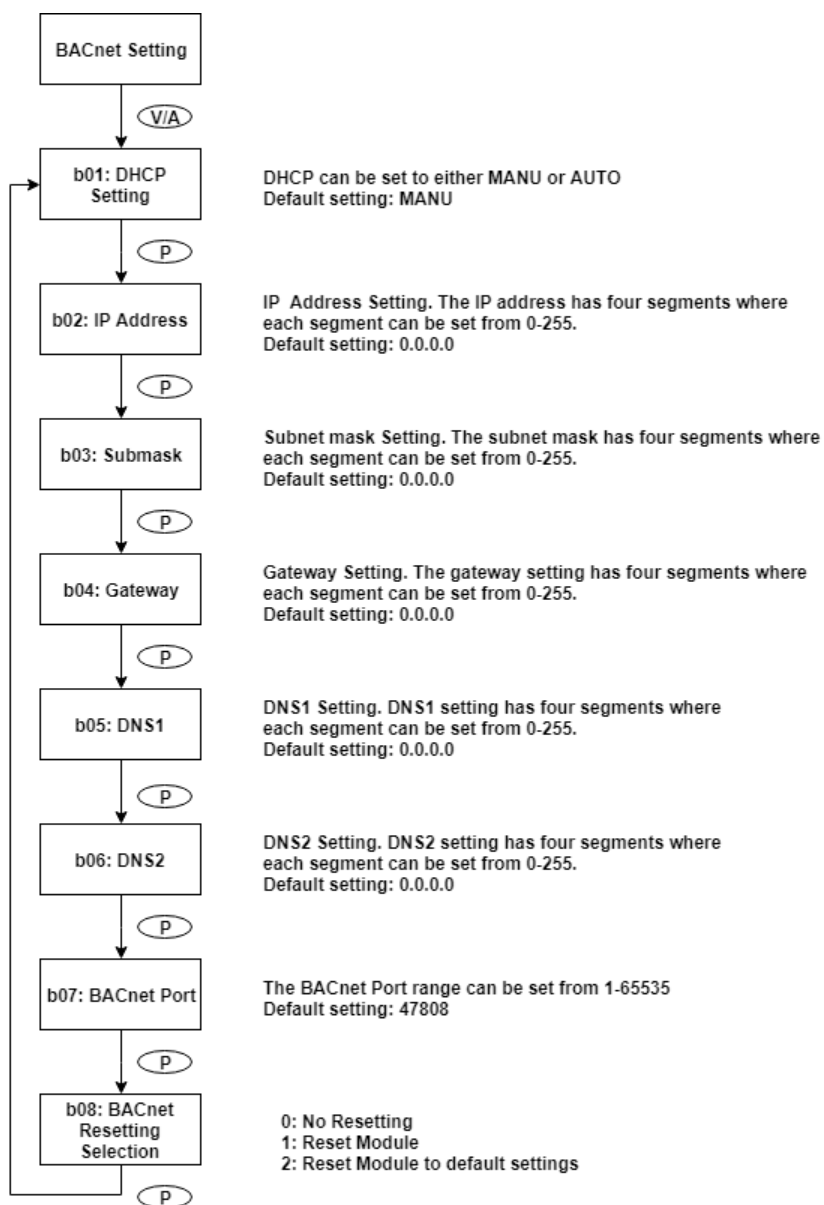

Figure 3-35 - BACnet IP module rolling screen sequence

Acuvim II Series Power Meter

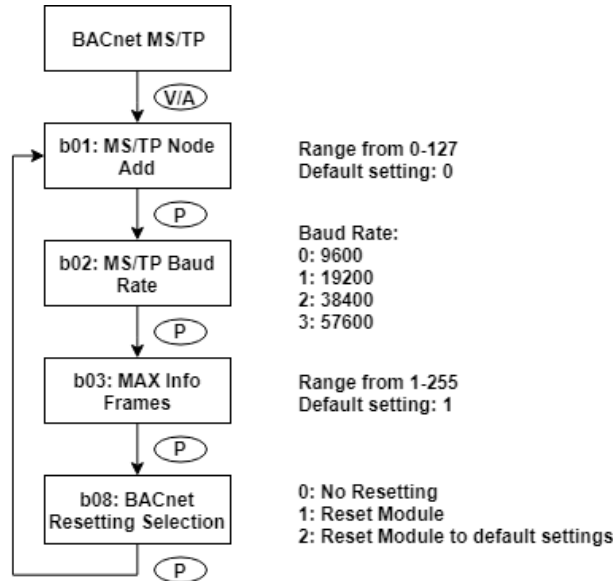

Figure 3-36 - BACnet MS/TP settings

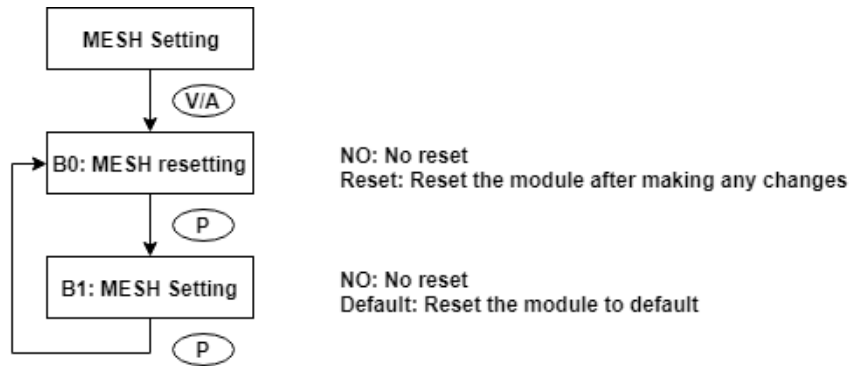

Figure 3-37 - Mesh settings

### 3.7.6 Alarm Settings

In the alarm parameter mode, the user can view and modify the parameters.

#### Key functions for finding the alarm parameter:

- Press **H** to return to parameter selection mode.
- The screen will roll to the next page each time **P** is pressed and will return to the first page when **P** is pressed on the last page.
- The screen will roll to the last page each time **E** is pressed and will return to the last page when **E** is pressed at the first page.
- Press **V/A** to modify the selected parameter.

#### Key functions for modifying the parameter:

- Press **H** to move the flashing cursor to the next position.
- Press **P** to increase the number by 1.
- Press **E** to decrease the number by 1.
- Press **V/A** to confirm the modification and return to parameter selection mode.

The following figure shows the sequence:

## Acuvim II Series Power Meter

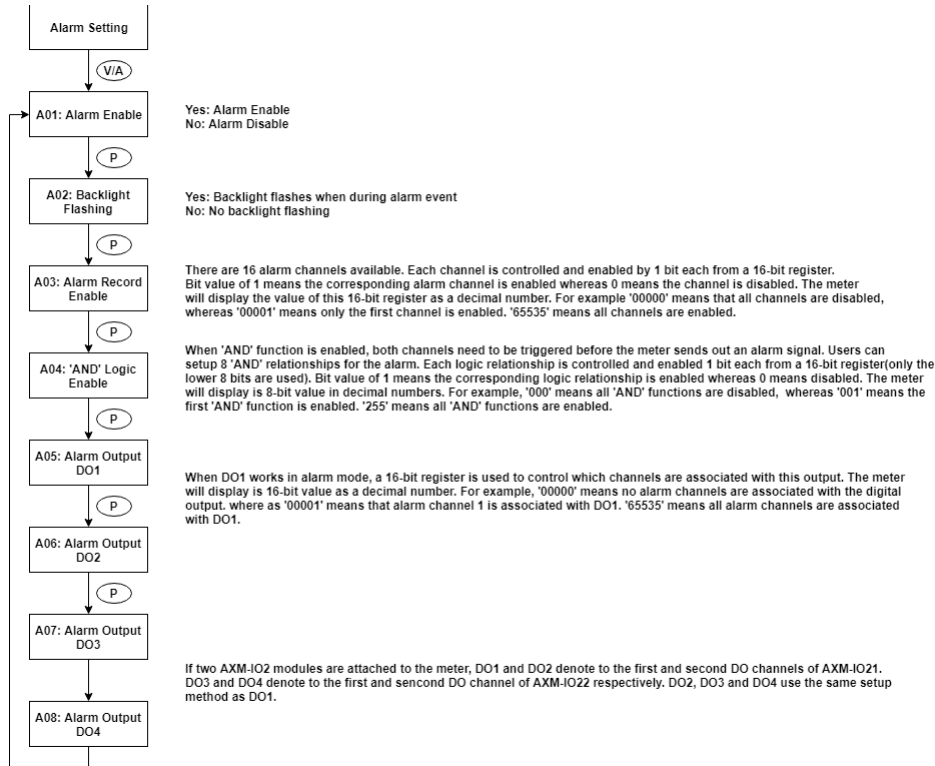

### 3.8 Page Recovery Function

The Acuvim II series meter includes a page recovery function. This means that the meter stores the current display page in the non-volatile memory upon power loss and reloads the page when power is recovered. If power goes off when viewing under the parameter setting mode, the meter will show voltage displayed when the power is recovered. If power goes off when viewing under the expanded I/O module data mode, and if this expanded I/O module is not connected when power recovers, the meter will show the voltage display page instead.

## Chapter 4: Detailed Functions and Software

The Acuvim II series meter contains advanced metering tools and is able to measure a multitude of power, energy and power quality parameters. Some advanced functions may not be accessible directly from the meter front; therefore, every meter can connect to our Acuvim software that helps to access the information. This chapter introduces these functions and software.

### 4.1 Acuvim Software

The Acuvim software is a free data logging software that can be used to read the meters data, as well as configure and view settings. This software is free to download from our website ([www.accuenergy.com](http://www.accuenergy.com)).

The software uses the Modbus protocol to communicate with the meter. Users can connect to the software via the built in RS485 communication port or by Modbus TCP via communications module.

#### 4.1.1 Connect using RS485

Using the meters RS485 communication port users can connect to the software using an RS485 to USB converter. The RS485 port on the meter has three terminals where 14 is labeled A (positive), terminal 15 is B (negative), and terminal 16 is S (Shield). The communication port uses half-duplex two wire RS485 communication where the data is passed in one direction at a time, and the send (TX) and receive (RX) signals are shared between the two wires.

The figure below depicts how the RS485-USB converter should be wired into the meter, the T/R+ on the converter connected to terminal 14(A) on the Acuvim II meter, and T/R- on the converter connected to terminal 15(B) on the meter.

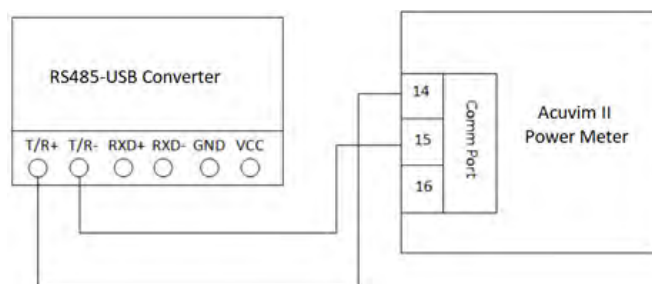

Figure 4-1 - RS485-USB converter connection to Acuvim II meter

## Acuvim II Series Power Meter

Once the physical wiring is connected between the converter cable and the Acuvim II meter, the meter's communication settings need to be confirmed. The communication settings in this case are the meter's Modbus device address (slave ID), the communication speed or baud rate, and the parity. By default, the meter has the following communication settings:

- **Modbus Device Address:** 1
- **Baud Rate:** 19200
- **Parity:** Non1 (no parity, 1 stop bit)

**NOTE:** If users are connecting to a meter with no display (DIN rail mount model), please note that the default baud rate of the meter is 9600 when the meter is first powered up. After one minute of being powered, the default baud rate changes to 19200.

Next, the COM port must be confirmed for the computer that is being used to connect to the meter. To determine the COM port that is assigned, open the Device Manager on the computer. Under the **Port (COM & LPT)** heading, find the COM port number; for example, in the figure below, COM4 has been assigned to the RS485-USB converter. Note the COM port number as it is required to connect to the software.

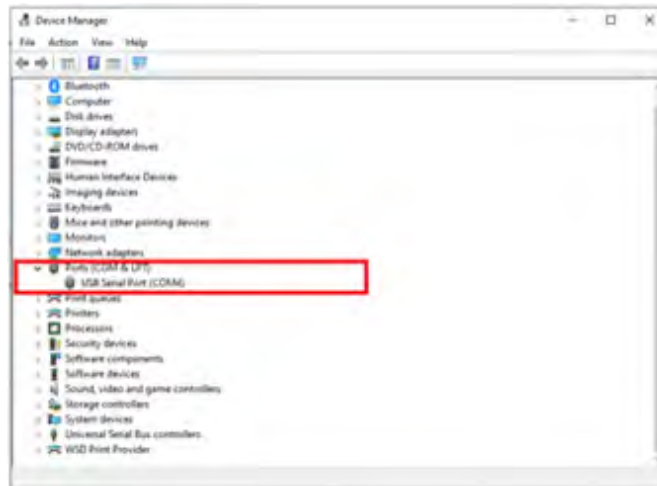

Figure 4-2 - COM port number assigned to USB converter

## Chapter 4: Detailed Functions and Software

Open the **Acuview** software. The following New Connection screen will appear where users are required to provide the type of connection, COM port, baud rate, parity, and scan interval.

Select the connection type as **Serial Port** and then select the COM port number assigned to the USB converter cable from the device manager.

Next, enter in the communication settings (Baud Rate, Parity) from the Acuvim II meter into the software. The scan interval can be left as the default of 200ms. Click **OK** after all settings have been entered.

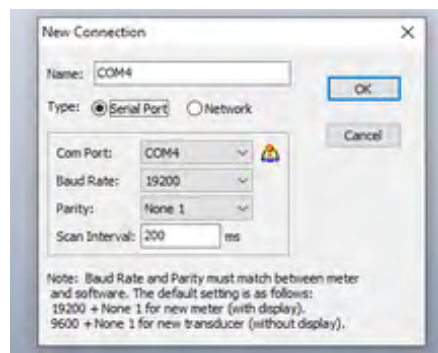

Figure 4-3 - Creating new connection on the Acuview software

Next, the device will need to be added to the software where users will need to enter in the device type, the connection, device address, and a description for the device.

For the device type, users can select the Acuvim II meter model they are using (Acuvim IIR, Acuvim IIW). The connection would be referring to the connection that was created in the step above in Figure 4-3. The device address is in reference to the Modbus device address from the Acuvim II meter, and the description field is used for labeling the device in the software.

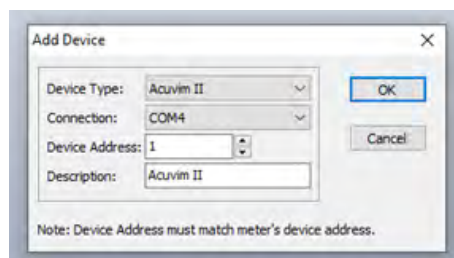

Figure 4-4 - Adding Acuvim II device to the software

After clicking **OK**, the meter should automatically connect to the software, and you should see data appear on the main screen in Acuview. If the meter does not initially connect, click on the **Operation** menu and select **Connect**.

## Acuvim II Series Power Meter

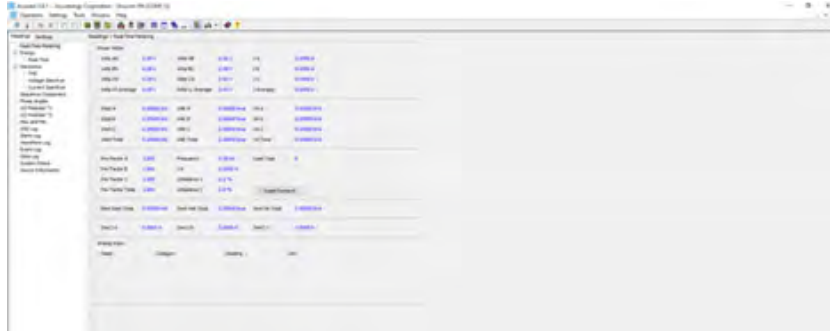

Figure 4-5 - Acuvim Software interface once successfully connected to the meter

**NOTE:** For methods on how to connect to the software using Modbus TCP via a communications module, please refer to the AXM-WEB2 or AXM-WEB-PUSH User Manual which can be found on our website: [www.accuenergy.com](http://www.accuenergy.com).

### 4.2 Basic Analog Measurements

The Acuvim software allows users to view all real-time analog measurements with high accuracy.

The real-time parameters that the meter can measure include voltage, current, power, frequency, power factor, demand, etc.

| Readings > Real-Time Metering |            |                  |               |   |             |
|-------------------------------|------------|------------------|---------------|---|-------------|
| <b>Power Meter</b>            |            |                  |               |   |             |
| Volts AN                      | 131.44 V   | Volts AB         | 207.64 V      | I A   | 19.745 A    |
| Volts BN                      | 128.92 V   | Volts BC         | 207.64 V      | I B   | 20.392 A    |
| Volts CN                      | 101.82 V   | Volts CA         | 207.57 V      | I C   | 19.224 A    |
| Volts LN Average              | 120.73 V   | Volts LL Average | 207.62 V      | I Average                                   | 19.787 A    |
| Watt A                        | 2.56515 kW | VAR A            | -0.38674 kvar | VA A  | 2.59626 kVA |
| Watt B                        | 2.60608 kW | VAR B            | 0.32843 kvar  | VA B  | 2.62855 kVA |
| Watt C                        | 1.94880 kW | VAR C            | -0.14413 kvar | VA C  | 1.95827 kVA |
| Watt Total                    | 7.12003 kW | VAR Total        | -0.20245 kvar | VA Total                                    | 7.18308 kVA |
| Pwr Factor A                  | 0.988      | Frequency        | 49.88 Hz      | Load Type                                   | C           |
| Pwr Factor B                  | 0.991      | I N              | 0.0000 A      |   |             |
| Pwr Factor C                  | 0.995      | Unbalance V      | 0.0 %         |   |             |
| Pwr Factor Total              | 0.991      | Unbalance I      | 0.0 %         | <input type="button" value="Reset Demand"/> |             |
| Dmd Watt Total                | 7.12145 kW | Dmd VAR Total    | -0.19630 kvar | Dmd VA Total                                | 7.18718 kVA |
| Dmd I A                       | 19.755 A   | Dmd I B          | 20.380 A      | Dmd I C                                     | 19.217 A    |
| <b>Analog Input</b>           |            |                  |               |   |             |
| Name                          | Category   | Reading          | Unit          |   |             |

Fig 4-6 - Real-Time Metering

### 4.2.1 High Speed Monitoring

The Acuvim II V3 model supports High Speed Monitoring which includes either 100ms or 20ms sampling rates.

The high speed parameters include most real time parameters for 100ms, however at 20ms sampling the meter only supports voltage, current, total active/reactive power and frequency.

The following images show the parameters for both 100ms and 20ms:



Fig 4-6-1a - 100ms High Speed Monitoring



Fig 4-6-1b - 20ms High Speed Monitoring

### 4.3 Demand

This meter can support demand measurements consisting of power and current demand readings. The demand can be found in the real-time section as outlined in Figure 4-7 below.

The demand will be calculated using the demand calculation method configured in the meter. The calculation types include:

- **Fixed Window:** The demand is calculated based on selecting the calculation period between 1-30 minutes. The meter will calculate and update the demand values at the end of each calculation period.
- **Sliding Window:** The demand is calculated by selecting the calculation period between 1-30 minutes. The meter will average the energy accumulated within this period of time and the demand value is updated every minute.
- **Thermal:** The demand is calculated based on thermal response, used in thermal demand meters. This method uses a sliding window to update the demand value at the end of each calculation period.
- **Rolling Window:** The demand is based on selecting a calculation period between 1-30 minutes, a sub interval (Demand Calculation Slip Time), and the demand value is updated at each sub interval. The sub interval must be a factor of the calculation period. For example, with a calculation period of 15 minutes, the sub interval can be configured as 5 minutes.

The demand calculation type and interval can be configured in the meter settings on either the software, which will be discussed in the software settings portion of this chapter, or from the front display of the meter (refer to Chapter 3 for accessing the demand settings).

| Readings > Real-Time Metering               |            |                  |               |              |             |
|---|------------|------------------|---------------|--------------|-------------|
| <b>Power Meter</b>                          |            |                  |               |              |             |
| Volts AN                                    | 131.44 V   | Volts AB         | 207.64 V      | I A          | 19.745 A    |
| Volts BN                                    | 129.92 V   | Volts BC         | 207.64 V      | I B          | 20.392 A    |
| Volts CN                                    | 101.82 V   | Volts CA         | 207.57 V      | I C          | 19.224 A    |
| Volts LN Average                            | 120.73 V   | Volts LL Average | 207.62 V      | I Average    | 19.787 A    |
| Watt A                                      | 2.56515 kW | VAR A            | -0.38674 kvar | VA A         | 2.59626 kVA |
| Watt B                                      | 2.60608 kW | VAR B            | 0.32843 kvar  | VA B         | 2.62855 kVA |
| Watt C                                      | 1.94880 kW | VAR C            | -0.14413 kvar | VA C         | 1.95827 kVA |
| Watt Total                                  | 7.12003 kW | VAR Total        | -0.20245 kvar | VA Total     | 7.18308 kVA |
| Pwr Factor A                                | 0.988      | Frequency        | 49.88 Hz      | Load Type    | C           |
| Pwr Factor B                                | 0.991      | IN               | 0.0000 A      |              |             |
| Pwr Factor C                                | 0.995      | Unbalance V      | 0.0 %         |              |             |
| Pwr Factor Total                            | 0.991      | Unbalance I      | 0.0 %         |              |             |
| <input type="button" value="Reset Demand"/> |            |                  |               |              |             |
| Dmd Watt Total                              | 7.12145 kW | Dmd VAR Total    | -0.19630 kvar | Dmd VA Total | 7.18718 kVA |
| Dmd I A                                     | 19.755 A   | Dmd I B          | 20.380 A      | Dmd I C      | 19.217 A    |
| <b>Analog Input</b>                         |            |                  |               |              |             |
| Name  | Category   | Reading          | Unit          |              |             |

Figure 4-7 - Demand Readings

## 4.4 Energy

The Acuvim II meter supports the writing of energy values which can be done via software or Modbus but not from the meter's display. This is used to configure the meter to start accumulating from a certain energy value.

### Energy Calculating mode

1. Users can select different energy calculating modes, fundamental based or full-wave based either from the meter-front or via communication. The fundamental based calculating is used to accumulate energy without taking harmonics into consideration while full-wave based calculating is used to accumulate energy including fundamentals and harmonics.

**NOTE:** When fundamental based calculating mode is selected, the PF calculation will be based on the fundamental wave.

**NOTE:** If user has 400Hz Acuvim II model, only the full-wave method is supported.

2. The energy reading can be set as either Primary or Secondary. Primary displays the energy accumulation in terms of the Primary measurement and Secondary will display the energy accumulation in terms of the secondary measurement with resolution of up to 1Wh. Users can configure this setting by either by pressing keys from the meter-front (refer to chapter 3), via Modbus communication though Acuvview software, or through Modbus registers.

**NOTE:** Acuvim II is able to display either primary energy or secondary energy on the LCD screen. However, it is only able to send out pulses according to secondary energy via the AXM-I/O module.



Figure 4-8 - Energy Readings

## Acuvim II Series Power Meter

### 4.5 Max/Min

Acuvim II series meter logs maximum and minimum value statistics for all real time, demand, THD parameters and also log the time that it occurred. All data is stored in non-volatile memory so that statistic information can be preserved even when the meter is loses power or gets shut off. All maximum and minimum data can be accessed via communication or from the meter front, however only timestamps information can only be accessed via communication.

Statistical data can be cleared via communication or from the meter-front.

The screenshot shows a software window titled "Readings > Max and Min". It contains a table with the following columns: Channel, Maximum, Time Stamp, Minimum, and Time Stamp. The data is as follows:

| Channel             | Maximum    | Time Stamp          | Minimum     | Time Stamp          |
|---------------------|------------|---------------------|-------------|---------------------|
| Volts AN            | 399.9 V    | 2019-08-14 07:16:09 | 0.0 V       | 2017-06-29 07:40:13 |
| Volts BN            | 129.6 V    | 2017-11-16 09:21:51 | 0.0 V       | 2017-06-29 07:40:13 |
| Volts CN            | 129.3 V    | 2017-11-16 09:21:51 | 0.0 V       | 2017-06-29 07:40:13 |
| Volts AB            | 121.1 V    | 2017-09-25 00:22:16 | 0.0 V       | 2017-02-16 07:31:46 |
| Volts BC            | 120.8 V    | 2017-08-25 00:22:16 | 0.0 V       | 2017-02-16 07:31:46 |
| Volts CA            | 62.4 V     | 2018-08-30 13:22:56 | 0.0 V       | 2017-02-16 07:31:46 |
| I A                 | 99.96 A    | 2019-07-10 21:51:45 | 0.000 A     | 2017-05-04 15:14:47 |
| I B                 | 9.600 A    | 2018-12-04 20:05:51 | 0.000 A     | 2017-05-04 15:14:47 |
| I C                 | 9.600 A    | 2018-12-04 20:05:51 | 0.000 A     | 2017-05-04 15:14:47 |
| Watt Total          | 7.960 kW   | 2019-08-14 07:07:54 | -1.400 kW   | 2017-06-22 10:35:32 |
| VAR Total           | 0.600 kvar | 2017-06-22 10:35:32 | -0.840 kvar | 2017-02-23 07:31:55 |
| VA Total            | 7.960 kVA  | 2019-08-14 07:07:54 | 0.000 kVA   | 2017-02-23 07:31:55 |
| Power Factor Total  | 1.000      | 2017-02-23 07:31:55 | -1.000      | 2018-10-25 09:54:42 |
| Frequency           | 64.44 Hz   | 2018-12-21 10:31:09 | 0.00 Hz     | 2017-02-23 07:31:55 |
| Watt Total (Demand) | 7.960 kW   | 2019-08-14 07:22:45 | -1.080 kW   | 2018-09-24 13:32:00 |
| VAR Total (Demand)  | 0.400 kvar | 2018-09-25 06:51:17 | -0.720 kvar | 2017-03-22 03:30:25 |
| VA Total (Demand)   | 7.960 kVA  | 2019-08-14 07:22:45 | 0.000 kVA   | 2017-02-16 07:31:46 |
| Unbalance V         | 100 %      | 2017-09-25 00:21:59 | 0.0 %       | 2017-02-16 07:31:46 |
| Unbalance I         | 99.5 %     | 2018-09-24 11:15:25 | 0.0 %       | 2017-02-16 07:31:46 |
| THD Volts AN/AB     | 40.93 %    | 2019-08-14 07:06:30 | 0.00 %      | 2017-02-23 07:31:55 |
| THD Volts BN/CA     | 12.47 %    | 2018-08-29 11:37:35 | 0.00 %      | 2017-02-23 07:31:55 |
| THD Volts CN/BC     | 12.40 %    | 2018-08-29 11:37:35 | 0.00 %      | 2017-02-23 07:31:55 |
| THD I A             | 210.38 %   | 2018-11-28 19:16:36 | 0.00 %      | 2017-02-23 07:31:55 |
| THD I B             | 211.41 %   | 2018-11-28 19:16:36 | 0.00 %      | 2017-02-23 07:31:55 |

At the bottom of the window, there are two buttons: "Reset Max and Min" and "Save".

Figure 4-9 Max and Min readings

## 4.6 Harmonics and Power Quality Analysis

### 4.6.1 Harmonics & THD

Acuvim II series meter can measure and analyze several power quality parameters which is useful for further analyzing the voltage and current signals measured by the meter.

**Total Harmonic Distortion:** A ratio of the sum of powers in all harmonic components to power of the fundamental frequency. The Acuvim II meter also supports even and odd order THD, where even order harmonics are the 2nd, 4th, 6th, and so on and odd order harmonics are 3rd, 5th, 7th, etc.

**Crest Factor:** Is the ratio between either the peak current or voltage and the RMS value.

**THFF:** Stands for Telephone Harmonic Form Factor and is the ratio of the square root of the sum of the squares for all the sine wave components (including alternating current waves both fundamental and harmonic) to the RMS value of the entire wave form.

**K Factor:** A measure of the heating effect caused by current harmonics that helps determine the linearity of a load. If the K factor is 1, this means that the load is linear and that there are no harmonics present. However, a K factor value greater than one means that the load is not linear and that there is a higher heating effect caused by the harmonics in the system.

Harmonics are essentially high frequency waveforms that are combined with or superimposed over the fundamental frequency. The fundamental frequency is the circuit frequency which is 50 or 60Hz depending on the system that is being monitored. The Acuvim II meter supports individual voltage and current harmonics up to the 63rd order. This means that the meter can monitor the percentage of harmonics present up to the 63rd order (63 times the fundamental frequency). This provides users with an in depth examination of the power quality for the system they are monitoring.

**NOTE:** The 400 Hz Acuvim II model only supports 2nd~15th harmonics.

| Readings > Harmonics > THD |         |                  |         |                  |         |
|----------------------------|---------|------------------|---------|------------------|---------|
| THD Volts AN/AB            | 25.08 % | THD I A          | 0.00 %  |                  |         |
| THD Volts BN/CA            | 23.21 % | THD I B          | 0.00 %  |                  |         |
| THD Volts CN/BC            | 20.56 % | THD I C          | 0.00 %  |                  |         |
| THD Volts Average          | 22.95 % | THD I Average    | 0.00 %  |                  |         |
| Odd THD V A                | 14.61 % | Odd THD V B      | 15.62 % | Odd THD V C      | 12.96 % |
| Even THD V A               | 20.31 % | Even THD V B     | 17.18 % | Even THD V C     | 15.95 % |
| THFF V A                   | 25.38 % | THFF V B         | 23.48 % | THFF V C         | 24.05 % |
| Crest Factor V A           | 2.963   | Crest Factor V B | 2.965   | Crest Factor V C | 2.680   |
| Odd THD I A                | 0.00 %  | Odd THD I B      | 0.00 %  | Odd THD I C      | 0.00 %  |
| Even THD I A               | 0.00 %  | Even THD I B     | 0.00 %  | Even THD I C     | 0.00 %  |
| K Factor I A               | 0.0     | K Factor I B     | 0.0     | K Factor I C     | 0.0     |

Figure 4-10 - THD Reading

## Acuvim II Series Power Meter

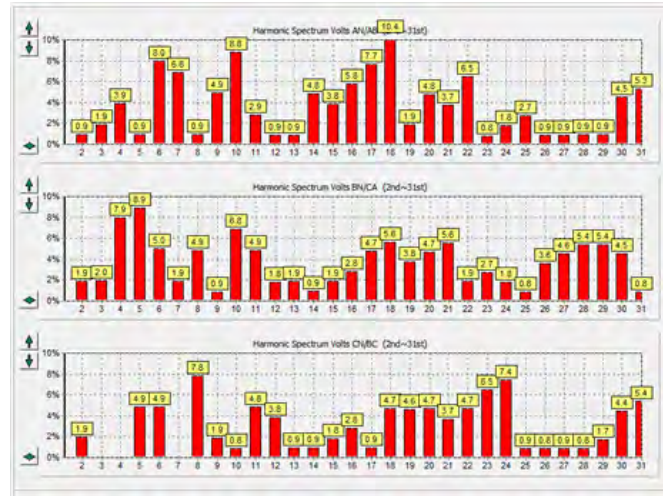

Figure 4-11 - Individual Harmonic Reading

### 4.6.2 Amplitude and Angle

This section provides users with the amplitude and phase angle details of the harmonics being measured by the meter. For example if the voltage input to the meter is 120V, and a harmonic reading of 10% for the 2nd order, the amplitude in this case will show 12V. Both voltage harmonics and current harmonic amplitude/angles can be viewed. Users can view from the 2nd to 63rd order by using the scroll bar on the software.

| Readings > Harmonics > THD |         |                  |         |                  |         |
|----------------------------|---------|------------------|---------|------------------|---------|
| THD Volts AN/AB            | 25.08 % | THD I A          | 0.00 %  |                  |         |
| THD Volts BN/CA            | 23.21 % | THD I B          | 0.00 %  |                  |         |
| THD Volts CN/BC            | 20.96 % | THD I C          | 0.00 %  |                  |         |
| THD Volts Average          | 22.95 % | THD I Average    | 0.00 %  |                  |         |
| Odd THD V A                | 14.61 % | Odd THD V B      | 15.62 % | Odd THD V C      | 12.96 % |
| Even THD V A               | 20.31 % | Even THD V B     | 17.58 % | Even THD V C     | 15.95 % |
| THFF V A                   | 25.38 % | THFF V B         | 23.48 % | THFF V C         | 24.05 % |
| Crest Factor V A           | 2.963   | Crest Factor V B | 2.965   | Crest Factor V C | 2.680   |
| Odd THD I A                | 0.00 %  | Odd THD I B      | 0.00 %  | Odd THD I C      | 0.00 %  |
| Even THD I A               | 0.00 %  | Even THD I B     | 0.00 %  | Even THD I C     | 0.00 %  |
| K Factor I A               | 0.0     | K Factor I B     | 0.0     | K Factor I C     | 0.0     |

Figure 4-11-a - Amplitude and Angle Section

### 4.6.3 Phase Angles

Phase angle indicates the angle between phase A voltage and other voltage/current parameters in a range from 0 to 360 degrees. These readings allows the users to analyze the phase angle difference between each phase and also determine if current/voltage are incorrectly out of phase, which tend to be related to wiring/installation issues with the meter.

- When the wiring is set to 2LL or 3LL, the meter provides the phase angles of U23, U31, I1, I2, I3 corresponding to U12 (reference angle).
- When the wiring is set to 3LN, the phase angles are U2, U3, I1, I2, and I3 where U1 is the reference angle.
- When the wiring is set to 1LL, the meter has phase angle of U2, I1, and I2 where U1 is the reference angle.

The phase angle readings from Acuvue software are shown in Figure 4-12. The image provides the phase angle reading of a three-phase four wire system (3LN), where the three-phase voltage is 120 degrees apart. The current phase angle for three-phase four wire balanced systems is usually aligned with the voltage phase angles.

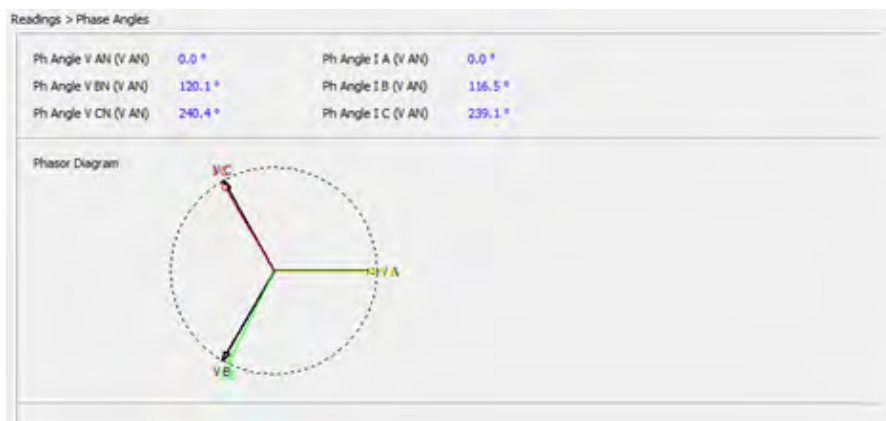

Figure 4-12 - Phase Angle Diagram & Readings

#### 4.6.4 Sequence Component and Unbalance Analysis

Acuvim II series meter is able to perform sequential analysis for the input signal. The sequence components allow users to represent three-phase systems as individual into three single phase networks, where these networks can be described as the positive sequence, negative sequence and zero sequence.

**Positive Sequence:** Three phasors of the positive sequence are equal in magnitude and are spaced by 120 degrees.

$$I_0 = \frac{1}{3} * (I_a + aI_b + a^2I_c)$$

$$V_0 = \frac{1}{3} * (V_a + aV_b + a^2V_c)$$

$$a = 1\angle 120^\circ$$

$$a^2 = 1\angle 240^\circ$$

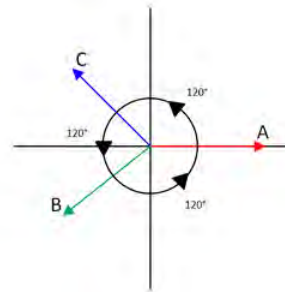

Figure 4-13 - Positive Sequence Phasor Diagram

**Negative Sequence:** Similar to the positive sequence, the negative phase-sequence phasors are of equal in magnitude and spaced by 120 degrees. The main difference between positive and negative sequence is the phase rotation, where the negative sequence has phase B phase leading phase A rather than lagging in the positive sequence.

$$I_1 = \frac{1}{3} * (I_a + a^2I_b + aI_c)$$

$$V_1 = \frac{1}{3} * (V_a + a^2V_b + aV_c)$$

$$a = 1\angle 120^\circ$$

$$a^2 = 1\angle 240^\circ$$

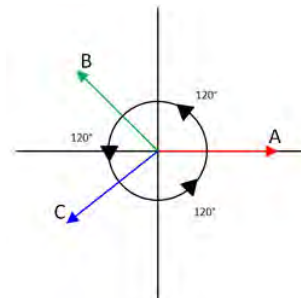

Figure 4-14 - Negative Sequence Phasor Diagram

**Zero Sequence:** Combines a set of three phasors that are equal in magnitude and in-phase with each other. Unlike the positive and negative sequence, there is no rotation associated with the zero sequence.

$$I_0 = \frac{1}{3} * (I_a + I_b + I_c)$$

$$V_0 = \frac{1}{3} * (V_a + V_b + V_c)$$

Figure 4-15 - Zero Sequence Phasor Diagram

**Unbalance Factor**

The unbalance factor allows users to understand the percentage in which the voltage and current are unbalanced. The factor is a percentage of the ratio of the negative/zero sequence component to the positive sequence component, and essentially tells users that the magnitude, as well as the phase angles, between of the three-phase voltage/current is not equal. Figure 4-16 shows the unbalance and sequence component reading from the Acuvue software.

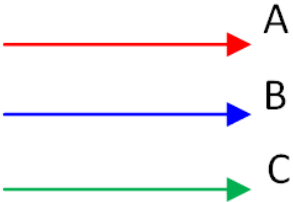
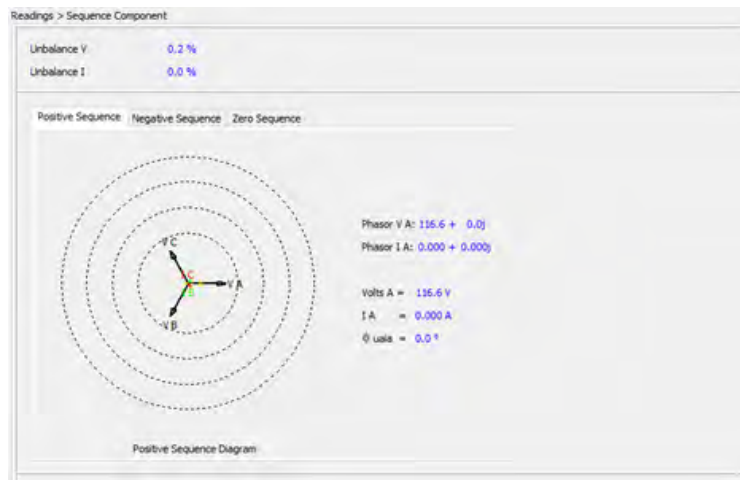

Figure 4-16 - Unbalance and Sequence Component Reading

### 4.7 Alarm

Acuvim II series meter supports an over/under limit alarming function. When the monitored parameter goes over or under the preset limit and stays at the level over the preset time delay, the alarm will be triggered. The alarm can be configured directly from the meter display, the Acuvim software, or via Modbus communication.

The meter can have a maximum of 16 alarm channels configured. If users have extended I/O modules attached, the alarms can trigger different functions, such as a relay output or digital output, which can be used to activate downstream devices such as a beacon light or buzzer. There is an option to have the meter's display flash when an alarm is triggered which provides users a visual cue that an alarm condition has been triggered.

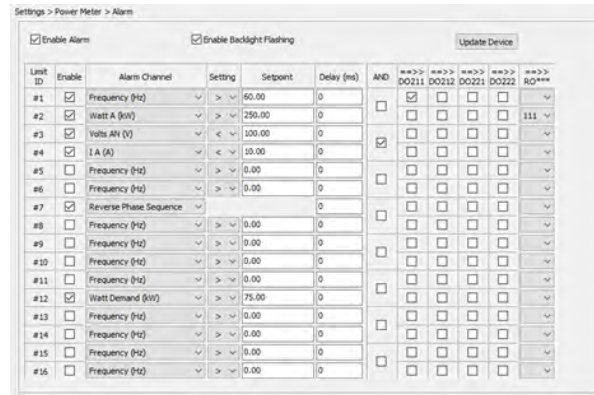

Figure 4-17 - Alarm Setting

Before using the alarming function, alarm conditions such as logic dependency, target set point, and time delay must be correctly set. Settings can be accessed and modified from the software via the communication connection as shown in Fig 4-17. To access the alarm settings from the meter display, refer to Chapter 3 for the screen sequence. To configure the alarms using Modbus, refer to Chapter 6 to view the register list.

**Alarm Channel/Parameter Code:** Users can select from the drop down menu the desired parameter to alarm in the alarm settings page. If setting the alarms using Modbus or from the meters display enter in the alarm code for the desired parameter, the alarm code table can be seen in table 4-3. For example, "0" would represent frequency and "17" would represent Total System Power.

**Comparison Mode:** Users can select three, different alarm conditions:

1. Greater than (>)
2. Equal to (=)
3. Smaller than (<)

For example: If you choose the target parameter to be "Frequency," the condition to be "greater than" and set point to be "50," the alarm will be triggered when the frequency is greater than 50Hz and will come out of the alarm condition when the frequency is less than 50Hz.

**Setpoint:** The setpoint is the parameter value used in the alarm condition and is the alarm condition value whether you want to trigger below, under, or when the parameter is equal to this setpoint value.

**Delay Time:** If the alarm condition lasts for the preset time period, the alarm signal will be triggered. The delay range is from 0 to 3000 (unit: 10ms). When it is set to 0, there is no delay and alarm will be triggered when the alarm condition is met. If it is set to 20, there will be a 200ms (20 x 10ms) delay.

**Output to Digital Output:** If using an AXM-IO2 module, users have the option to output a pulse signal when an alarm is triggered.

Table 4-1 - Digital Output Alarm Translation

| DO Code | DO Channel | IO Module |
|---------|------------|-----------|
| DO211   | DO1        | AXM-IO2-1 |
| DO212   | DO2        | AXM-IO2-1 |
| DO221   | DO1        | AXM-IO2-2 |
| DO222   | DO2        | AXM-IO2-2 |

**Output to Relay:** If using an AXM-IO1 or AXM-IO3 module, users have the option to send a signal to the relay output when an alarm is triggered. Select one of the following options in the RO drop-down menu:

Table 4-2 - Relay Output Alarm Translation

| RO Code | RO Channel | IO Module |
|---------|------------|-----------|
| 111     | RO1        | AXM-IO1-1 |
| 112     | RO2        | AXM-IO1-1 |

## AccuVim II Series Power Meter

| RO Code | RO Channel | IO Module |
|---------|------------|-----------|
| 121     | RO1        | AXM-IO1-2 |
| 122     | RO2        | AXM-IO1-2 |
| 311     | RO1        | AXM-IO3-1 |
| 312     | RO2        | AXM-IO3-1 |
| 321     | RO1        | AXM-IO3-2 |
| 322     | RO2        | AXM-IO3-2 |

**NOTE:** If RO is under alarming mode, it can only work in the "latch" mode.

Table 4-3 - Alarming Parameter Code Table

| Alarming Parameter Code | Alarming Parameter    | Alarming Parameter Code | Alarming Parameter       | Alarming Parameter Code | Alarming Parameter                 | Alarming Parameter Code | Alarming Parameter |
|-------------------------|-----------------------|-------------------------|--------------------------|-------------------------|------------------------------------|-------------------------|--------------------|
| 0                       | Frequency             | 21                      | Total Reactive Power     | 42                      | Analog Input Channel 2 (AXM_IO3-1) | 63                      | DI2 (AXM-IO3-1)    |
| 1                       | Phase A Voltage       | 22                      | Phase A Apparent Power   | 43                      | Analog Input Channel 1 (AXM-IO3-2) | 64                      | DI3 (AXM-IO3-1)    |
| 2                       | Phase B Voltage       | 23                      | Phase B Apparent Power   | 44                      | Analog Input Channel 2 (AXM-IO3-2) | 65                      | DI4 (AXM-IO3-1)    |
| 3                       | Phase C Voltage       | 24                      | Phase C Apparent Power   | 45                      | Active Power Demand                | 66                      | DI1 (AXM-IO1-2)    |
| 4                       | Average Phase Voltage | 25                      | Total Apparent Power     | 46                      | Reactive Power Demand              | 67                      | DI2 (AXM-IO1-2)    |
| 5                       | Line Voltage AB       | 26                      | Phase A Power Factor     | 47                      | Apparent Power Demand              | 68                      | DI3 (AXM-IO1-2)    |
| 6                       | Line Voltage AC       | 27                      | Phase B Power Factor     | 48                      | Phase A Current Demand             | 69                      | DI4 (AXM-IO1-2)    |
| 7                       | Line Voltage BC       | 28                      | Phase C Power Factor     | 49                      | Phase B Current Demand             | 70                      | DI5 (AXM-IO1-2)    |
| 8                       | Average Line Voltage  | 29                      | Total Power Factor       | 50                      | Phase C Current Demand             | 71                      | DI6 (AXM-IO1-2)    |
| 9                       | Phase A Current       | 30                      | Voltage Unbalance Factor | 51                      | Reverse Phase Sequence             | 72                      | DI1 (AXM-IO2-2)    |

## Chapter 4: Detailed Functions and Software

| Alarming Parameter Code | Alarming Parameter     | Alarming Parameter Code | Alarming Parameter                 | Alarming Parameter Code | Alarming Parameter | Alarming Parameter Code | Alarming Parameter |
|-------------------------|------------------------|-------------------------|------------------------------------|-------------------------|--------------------|-------------------------|--------------------|
| 10                      | Phase B Current        | 31                      | Current Unbalance Factor           | 52                      | DI1 (AXM-IO1-1)    | 73                      | DI2 (AXM-IO2-2)    |
| 11                      | Phase C Current        | 32                      | Load Characteristic                | 53                      | DI2 (AXM-IO1-1)    | 74                      | DI3 (AXM-IO2-2)    |
| 12                      | Average Current        | 33                      | Phase A (Vab) THD                  | 54                      | DI3 (AXM-IO1-1)    | 75                      | DI4 (AXM-IO2-2)    |
| 13                      | Neutral Current        | 34                      | Phase B (Vac) THD                  | 55                      | DI4 (AXM-IO1-1)    | 76                      | DI1 (AXM-IO3-2)    |
| 14                      | Phase A Power          | 35                      | Phase C (Vbc) THD                  | 56                      | DI5 (AXM-IO1-1)    | 77                      | DI2 (AXM-IO3-2)    |
| 15                      | Phase B Power          | 36                      | Average Voltage THD                | 57                      | DI6 (AXM-IO1-1)    | 78                      | DI3 (AXM-IO3-2)    |
| 16                      | Phase C Power          | 37                      | Phase A Current THD                | 58                      | DI1 (AXM-IO2-1)    | 79                      | DI4 (AXM-IO3-2)    |
| 17                      | Total System Power     | 38                      | Phase B Current THD                | 59                      | DI2 (AXM-IO2-1)    |                         |                    |
| 18                      | Phase A Reactive Power | 39                      | Phase C Current THD                | 60                      | DI3 (AXM-IO2-1)    |                         |                    |
| 19                      | Phase B Reactive Power | 40                      | Average Current THD                | 61                      | DI4 (AXM-IO2-1)    |                         |                    |
| 20                      | Phase C Reactive Power | 41                      | Analog Input Channel 1 (AXM-IO3-1) | 62                      | DI1 (AXM-IO3-1)    |                         |                    |

### 4.7.1 Alarm Log

The AcuVim II series meter has built-in alarm logging capabilities where 16 entries in total can be recorded.

The record sequence of these entries do not depend on the sequence of the 16 alarm channels. The meter begins logging alarm status starting from the 1st record location to the last one. Alarm logs are being recorded in a "cycle" fashion which means the latest event will overwrite the oldest record.

When over/under limit parameters return to normal, its value and timestamp will be recorded as well. Therefore, users can determine the over/ under limit duration by checking the time difference.

## Acuvim II Series Power Meter

| No. | Time Stamp          | ms  | Alarm Channel    | Value    | Status | Limit ID |
|-----|---------------------|-----|------------------|----------|--------|----------|
| 1   | 2019-08-20 11:55:58 | 321 | Volts LN Average | 120.7 V  | Out    | 2        |
| 2   | 2019-08-20 11:58:20 | 762 | Frequency        | 49.88 Hz | Out    | 1        |
| 3   | 2019-08-20 11:58:20 | 762 | Volts AN         | 131.4 V  | Out    | 4        |
| 4   | 2019-08-20 11:58:20 | 762 | Volts BN         | 128.9 V  | Out    | 5        |
| 5   | 2019-08-20 11:59:22 | 765 | I A              | 19.00 A  | Out    | 7        |
| 6   | 2019-08-20 11:59:22 | 765 | I C              | 19.00 A  | Out    | 9        |
| 7   | 2019-08-20 11:59:22 | 903 | I Average        | 19.00 A  | Out    | 3        |
| 8   | 0001-01-01 00:00:00 | 0   | Frequency        | 0.00 Hz  | IN     | 0        |
| 9   | 0001-01-01 00:00:00 | 0   | Frequency        | 0.00 Hz  | IN     | 0        |
| 10  | 0001-01-01 00:00:00 | 0   | Frequency        | 0.00 Hz  | IN     | 0        |
| 11  | 0001-01-01 00:00:00 | 0   | Frequency        | 0.00 Hz  | IN     | 0        |
| 12  | 0001-01-01 00:00:00 | 0   | Frequency        | 0.00 Hz  | IN     | 0        |
| 13  | 0001-01-01 00:00:00 | 0   | Frequency        | 0.00 Hz  | IN     | 0        |
| 14  | 0001-01-01 00:00:00 | 0   | Frequency        | 0.00 Hz  | IN     | 0        |
| 15  | 0001-01-01 00:00:00 | 0   | Frequency        | 0.00 Hz  | IN     | 0        |
| 16  | 0001-01-01 00:00:00 | 0   | Frequency        | 0.00 Hz  | IN     | 0        |

Figure 4-18 - Alarming Records

**No.:** There are 16 alarm entries in the alarm log and this number indicates the alarm number. For example, the newest alarm record number in Figure 4-18 is record entry 7.

**Timestamp:** The Acuvim II meter can log the timestamp for when the alarm occurred. The timestamp format is YYYY-MM-DD hh:mm:ss. The column to the right provides the millisecond reading for the timestamp.

**Alarm Channel:** The alarm channel column specifies which parameter in the Acuvim II meter was triggered.

**Value:** Displays the value that triggers the alarm condition as well as the value that brings the alarm back into normal condition.

**Alarming Status:** Indicates whether the alarm is triggered or not. For example, when the status is **OUT**, the alarm is triggered. When the alarm status is **IN**, the alarm is back to its normal condition.

**Limit ID:** Refers to the alarm (1-16) that was configured in the alarm settings.

Users can check whether there is a new alarm record as well as the log number associated with newest alarm record. The alarm log can also be reset from the software, the meter display (refer to Chapter 3 for screen sequence), or through Modbus communication (refer to Chapter 6).

The alarm logs can be saved via the Acuvim software as either plain text, .csv, or as an Excel file.

### 4.8 Meter Settings

The meter settings can be configured from the meter display (refer to chapter 3 for screen sequencing), through the Modbus registers (refer to chapter 6) and from the Acuvim software. The meter settings need to be configured correctly in order for the Acuvim II meter to read data. After configuring any of the meter settings users will need to click on **Update Device** at the bottom of the settings page in order for the setting to take effect.

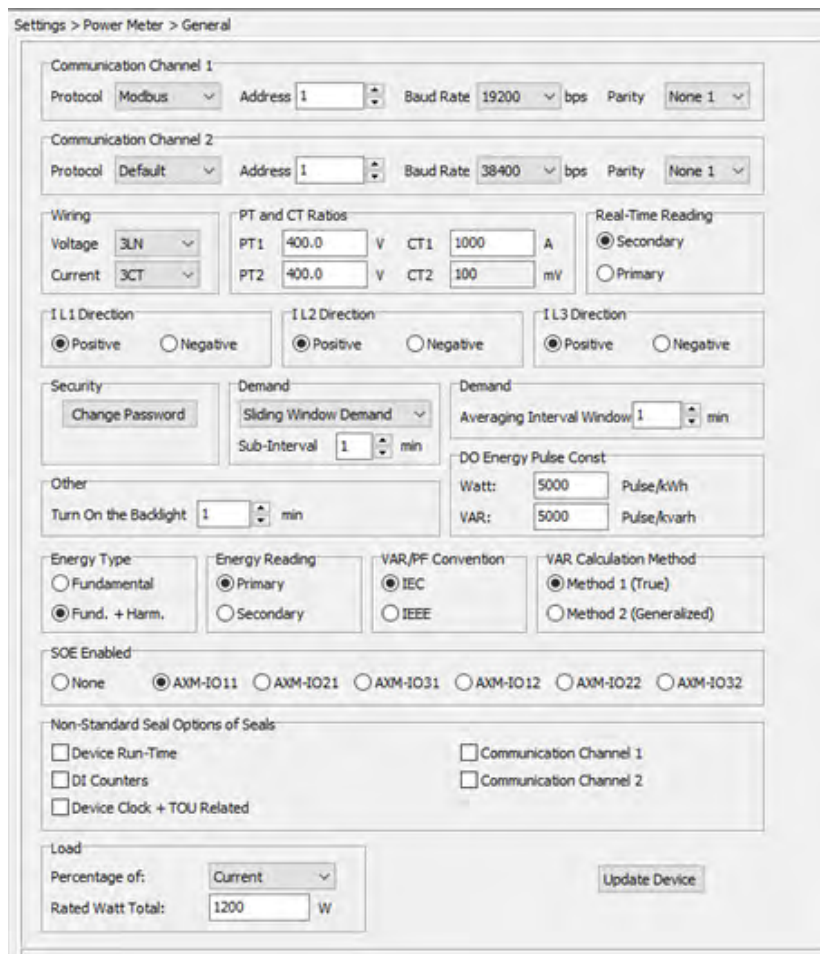

Figure 4-19 - Basic Meter Settings

### 4.8.1 Communication

- **Communication Channel 1** - Refers to the meters RS485 communication port; the settings here are relative to Modbus RTU or DNP over serial communication.
  - **Protocol** - Can be set as Modbus or DNP, Modbus is default
  - **Address** - Is the slave ID, the default is 1 and the range is 1-247.
  - **Baud Rate** - The communication speed in bits per second. The default is 19200 and the range is 1200-38400.
  - **Parity** - Is the communication parity; the default is None 1 which means no parity and 1 stop bit.
  
- **Communication Channel 2** - Refers to the secondary communication of the meter and is typically communications module (i.e. AXM-WEB2, AXM-MESH, AXM-BMS, etc.).
  - **Protocol** - Is the protocol used for the communications module; by default, it is set for OTHER, which is compatible with the Ethernet communications module. When using AXM-MESH, the protocol should be set for MESH. When using AXM-BMS, the protocol should be BACnet. When using AXM-WEB2, the protocol should be WEB2.
  - **Address** - The address to be used for accessing the meter via the communication protocol. For example, if using an Ethernet module and accessing the meter via Modbus TCP, this address would be used as the slave ID.
  - **Baud Rate** - The baud rate should be the communication speed required for communication between meter and communications module. By default, this is set for 38400 which is compatible with AXM-WEB2 and AXM-WEB-PUSH modules. However, if using the AXM-MESH module, the baud rate must be configured as 9600.
  - **Parity** - The parity setting is None 1 by default which is required for communication with the external communication modules.

### 4.8.2 Wiring, CT/PT Ratios

- **Wiring Mode**
  - **Voltage** - The Voltage wiring refers to the type of system that is being monitored by the Acuvim II meter. By default, the wiring is set 3LN (3 line and neutral) connection. For more information regarding wiring, refer to Chapter 2.
  - **Current** - The Current wiring setting refers to the number of CTs being used. By default, the meter is set for 3CT; for more information regarding CT wiring see Chapter 2.
- **CT/PT Ratio**

- **PT1** - If using Potential Transformers with the meter at the voltage input, this setting refers to the Primary side rating of the transformer. The range is from 50.0-1000000.0. If PTs are not being used with the meter, this setting can be left as the default which is 400.0.
- **PT2** - If using Potential Transformers with the meter at the voltage input, this setting refers to the Secondary side rating of the transformer. The range is from 50.0-400.0. If PTs are not being used with the meter, this setting can be left as the default which is 400.0.
- **CT1** - The CT1 setting refers to the Primary side rating of the current transformers being used with the meter. For example, if 200:5A CTs were being used, the CT1 setting would be configured as 200. Range is from 5-50000. The default CT1 value for 5A current input meters is 5, the default for 333mV/mA current inputs is 1, and the default for RCT current input meters is 1000.
- **CT2** - The CT2 setting refers to the secondary output of the current transformers. By default, the CT2 setting is already configured based on the current input type for the Acuvim II meter. For example, if you have a 5A current input meter, the CT2 value will already be configured for 5A. If you have a 333mV current input meter, the CT2 value is 333, and if you have an RCT current input meter, the CT2 value is 120/60 (120mV per 60Hz).

**NOTE:** For 5A current input meters, the CT2 value can be changed from 5A to 1A to support 1A secondary output CTs. The mA type current input meters can change the CT2 value from 80mA/100mA/200mA.

- **Real Time Reading** - The real time reading setting affects the Modbus registers read out of the Acuvim II meter. By default, the meter is set for Secondary mode which requires that a multiplier be applied to the register readout. In Primary mode, no multiplier is required.

**NOTE:** The real time reading setting does not affect the reading on the meter's display. It only affects the Modbus register reading of the meter when polling the Modbus registers.

- **Current Direction Setting** - The Acuvim II supports a setting that allows users to change the current direction in the meter. This is beneficial if the CTs have been installed in the reverse direction or if the leads have been terminated to the meter in reverse polarity. By default the current direction is configured to **positive** for I1, I2 and I3. Changing the current direction to negative is basically changing the phase angle of the current by 180 degrees allowing for correct adjustment if there is an installation error.

### 4.8.3 Demand Settings

- **Demand Calculation Method** - There are four types of demand that the Acuvim II meter supports: Fixed, Sliding Window, Thermal, and Rolling Window. See section 4.3 for a description for each calculation method.
- **Average Interval Window** - Is the averaging time used in the demand calculation method. The default is 15 minutes, and the range is from 1-30 minutes.
- **Sub-Interval** - The sub-interval time is used in the rolling block method where the sub-interval must be a factor of the averaging interval window. The default is 1 minute and the range is from 1-30 minutes.

### 4.8.4 Energy Reading & Power Factor Settings

- **Energy Type** - Users can configure the energy type as either fundamental or fundamental + harmonics.
- **Energy Reading** - The energy reading affects the meter calculation. If set for Primary, the meter will accumulate according to the primary usage. However, if configured as Secondary, the meter will use the secondary values for the energy accumulation where the resolution of 1 Wh can be seen.
- **VAR/PF Convention** - Users can select the convention as either IEC or IEEE.
- **VAR Calculation Method** - There are two ways to calculate reactive energy (power):
  1. **True Method** - This method uses the Budeanu Concept to calculate the **True** reactive power. This method generally uses the harmonic components to do the calculation instead of using the power vector triangle method. The most common definition of reactive power is Budeanu's definition, given by following expression for single phase circuit:

$$Q_b = \sum_{k=1}^{+\infty} I_{k,RMS} \cdot V_{k,RMS} \cdot \sin(\theta_k - \psi_k)$$

Budeanu proposed that apparent power consists of two orthogonal components, active power and nonactive power, which is divided into reactive power and distortion power:

$$D_b = \sqrt{S^2 - P^2 - Q_b^2}$$

2. **Generalized Method** - This method uses Fryze's concept to calculate the **Generalized** reactive power. This method separates instantaneous current into two components, active and

reactive currents. Active current is calculated as:

$$i_a(t) = \frac{P}{V_{RMS}^2} v(t)$$

And reactive current as:

$$i_r(t) = i(t) - i_a(t).$$

Active and reactive powers are as follows, where  $I_a$  and  $I_r$  represents RMS values of instantaneous active and reactive currents:

$$P = V_{RMS} \cdot I_a$$
$$Q_f = V_{RMS} \cdot I_r$$

#### 4.8.5 Load Percentage

The rated load can be represented in terms of either current or power.

- If current is selected, the rated current that is used would be the CT1 setting value in the PT/CT ratio settings. For example, if CT1 is set for 1000A and the average current the meter is monitoring is 500A, the load percentage would be 50% (500/1000).
- If power is selected, the rated primary power would be used in the load percentage calculation. The max primary power can be calculated as follows:

Max Primary Power without using PTs = 3 \* (480) \* (CT1)

Max Primary Power using PTs = 3 \* (PT1) \* (CT1)

The max primary power would be the power that is entered in the **Rated Watt Total** setting.

The load percentage is displayed on the front of the Acuvim II meter display. The load percentage is calculated based on the following equation:

$$\text{Load Percentage} = \left( \frac{\text{Active System Power}}{5A \text{ or } 1A \times \text{User Setting}} \right) \times 100\%$$

Where the meter will have either a 5A or 1A current input. If users have Acuvim II meters with

## Acuvim II Series Power Meter

Rogowski Coil (RCT), 333mV, or mA type Current Inputs, then 1A is used in this equation.

For example, if the max primary power of your system is 576000W (or 576kW), your system is currently using 211kW and the meters current input type is 5A, then the load percentage would be calculated as follows:

$$\text{Load Percentage} = \left( \frac{211kW}{5 \times 576kW} \right) \times 100\% = 7\%$$

The load percentage can only be viewed on the front LCD display of the Acuvim II meter; figure 4-20 shows where it is located on the display.

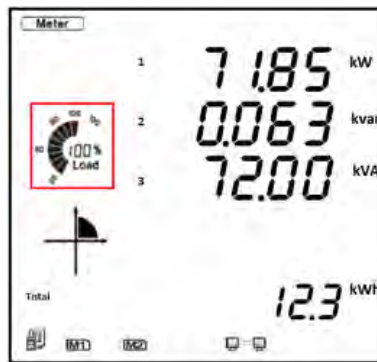

Figure 4-20 - Load Percentage

## 4.9 Time & Date Configuration

The meter can have its time and date configured only from the Acuvim software or by writing to the Modbus registers (refer to chapter 6), this is not configurable from the meter display. From the Acuvim software under the **System Status** section in the **Readings** tab users can configure the time and date for the meter.

The meter's time can be saved when the meter is powered off. However, if the meter is powered off for seven days or longer, the meter will reset back to its default time.

Users have the option to configure the time manually or synchronize with the PC's time to configure the time & date. Simply click on the **Set Device Clock** button for the setting to take effect.

**NOTE:** If users have a communications module, they will need to also configure the time from the module's web interface for the time to take effect.

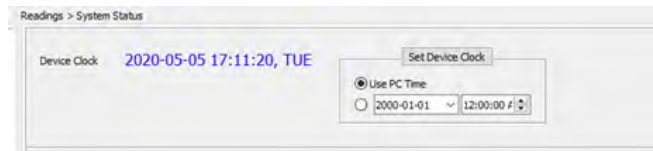

Figure 4-21 - Device Clock Configuration

### 4.10 Data Logging

The Acuvim IIR/IIW models support data logging onto the meter internal memory, where these models include 8MB of memory. The base model Acuvim II does not have the internal memory and does not support data logging capabilities. The meter is able to log data and store it on to the meters internal memory where users can read and pull the data from the memory. The data is logged and has time-stamps to allow users to monitor the exact time each record was logged at. Data logging is useful for users who wish to analyze the meters data for further research and billing purposes.

**NOTE:** If users have the base Acuvim II model, they can log data onto the computer's memory, however the Acuvim software must be running at all times in order for this to occur.

#### 4.10.1. Data Log Setting

The Acuvim IIR/IIW meters have three data logs available where each log can be independently programmed with individual settings. This means that each data log can be used to monitor different types of parameters, where the user can program up to 117 parameters per log.

**Data Logging Parameters** - Users can select the data logging parameters on the software from the parameter box located on the left of the interface. Users can select different types of parameters by selecting the parameter type in the drop down menu. The following types of parameter types are available for data logging:

- **Real-Time Metering** - Includes real time parameters such as voltage, current, power, etc.
- **Demand** - Includes both power and current demand parameters.
- **Energy** - Includes all energy types such as import, export, net, total, reactive, etc.
- **THD** - These parameters include all THD parameters such as THF, Crest Factor, THFF, etc.
- **Voltage & Current Harmonics** - Includes all individual harmonic parameters (2nd-63rd order harmonics for each voltage and current phase).
- **Sequence Components** - Includes positive, negative, and zero sequence components.
- **Phase Angle** - Voltage and Current phase angle parameters

## Acuvim II Series Power Meter

---

- **DI Counter** - If using an external I/O module, the user can log the DI counter value
- **Analog Output/Input Raw & Scaled values** - Users have the option to log the AO/AI values—both the raw values as well as the scaled values. More information on scaling for AO/AI can be found in Chapter 5.

Users can click and select the which parameters they want to log and click on the **Add** button to add the parameters to the log. Parameters can be deleted by selecting the parameter and clicking on the **Remove** button. Users can simply clear the entire data log by clicking on the **Clear All** button.

**Memory Usage** - As users add parameters to the data log there is **Space Allocation** section of the software that allows users to monitor the memory. Each data log can have 228 bytes, and each parameter uses roughly 4 bytes which then allows for a maximum of approximately 57 parameters per data log. The Max records will be dependent on the sector percentage that is configured for the data log. More records will be available the higher the sector percentage is.

**Registers & Sectors** - In this section, users can drag the **Sector** bar to an appropriate value. The sector range is from 0-100. Having the bar at the maximum of 100 means the data log will use all of the meter's memory. The total sector number between Data Log 1, Data Log 2 and Data Log 3 must not be more than 100. For example:

- If you are using just Data Log 1, you can have the sector all the way to 100
- If you are using Data Log 1 and Data Log 2, you can have both sectors at 50
- If you are using Data Log 1, Data Log 2 and Data Log 3, you can have the sectors at 30, 30, and 40.

**Logging Interval** - The logging interval determines how often the data is recorded in the data log. The logging interval can be configured from 1-1440 minutes, if the interval is set as 0 the data log is disabled. If users wish to log at quicker intervals they will need to use an communications module (AXM-WEB2 or WEB-PUSH) with the Acuvim II meter to log as fast as 1 second.

**Logging Mode** - There are three different types of logging modes that can be configured. Please note that the time will need to be configured correctly on the meter in order for the data to log successfully.

- **Immediate** - This starts logging immediately and does not stop. When the memory is full, the meter starts to overwrite the data from the oldest data log entry (first-in, first-out method).
- **Start Time** - This mode has a specific start time for the meter to begin logging. Users will

need to specify the start time by selecting the hour and minute. Once the data starts to log, it does not stop and, like the immediate logging mode, the data will start to overwrite the oldest data log entry once the memory is full.

- **Time Interval** - In this mode, there is a specific time interval where the meter is logging data. Users will need to specify both the start and end time for the data log. This will continue to log until the end time is reached or until the memory is full.

Once all configuration is complete user must click on **Update Device** at the bottom of the page, when updating the device data log 1,2, and 3 will be erased. If at anytime the user changes the data log configuration, when updating the device the existing data logs will be erased. It is important that users download and save all data logs before changing the configuration.

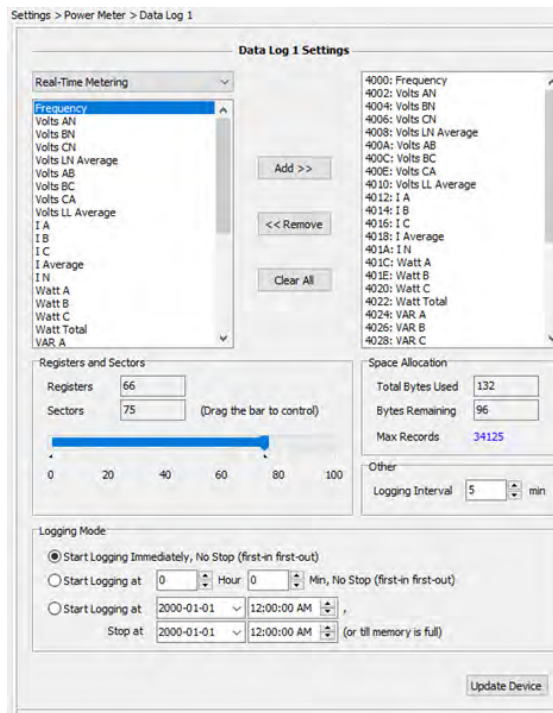

Figure 4-22 - The Data Log 1 Setting

**NOTE:** If the memory of the historical data log is full, the meter will erase the first sector in which the memory size is 65536 bytes (64kb). The following sector (the second sector) will become the first sector and the data from the erased sector will not be recoverable. Therefore, the user should save the whole log before the memory is full to maintain all data.

### 4.10.2 Retrieving the Data Log

The data logs can be retrieved directly from the Acuvim software or by Modbus (refer to Chapter 6). In the Acuvim software, under the readings tab, select **Data Log**. The top of the screen will show an overview of the three data logs which include the Max number of records for the data log, the number of used records, the record size, the window status, and the first/last recorded timestamp.

In the drop-down menu, users can select which data log they wish to retrieve the data from. By default, Data Log 1 will appear—use the drop-down menu to switch between Data Log 1, 2, and 3.

In the second drop-down menu, users can select the number of records, or a specific range of records, they wish to view. The following options are available:

- Read newest 50 records
- Read 1000 records
- Read 64000 records
- Read 1000 records (Select Time)
- Read 64000 records (Select Time)

In the **Start Record Num** users have the option to select which record number to begin reading the data log, this is not valid when reading the newest 50 records but is valid for all other reading options.

Once the data log settings are configured click on **Read**, the data will begin to populate and will take several minutes depending on the amount of records selected to read. The data will appear in a tabular format where users can scroll through the data. Figure 4-21 shows the data retrieval.

There are options to save the data where the data log file can be saved as a text, csv, or excel file. This is done by using the **Save to File** button.

The screenshot displays the 'Data Log Retrieval Page' with three data log summaries and a detailed data table.

| Data Log 1              |                     | Data Log 2              |                     | Data Log 3              |                     |
|-------------------------|---------------------|-------------------------|---------------------|-------------------------|---------------------|
| Max Records             | 309200              | Max Records             | 382000              | Max Records             | 0                   |
| Used Records            | 12696               | Used Records            | 12696               | Used Records            | 0                   |
| Record Size             | 30                  | Record Size             | 18                  | Record Size             | 12                  |
| Window Status           | Normal              | Window Status           | Normal              | Window Status           | Normal              |
| First Record Time Stamp | 2019-03-27 17:55:00 | First Record Time Stamp | 2019-03-27 17:55:00 | First Record Time Stamp | 0001-01-01 00:00:00 |
| Last Record Time Stamp  | 2019-08-20 12:30:00 | Last Record Time Stamp  | 2019-08-20 12:30:00 | Last Record Time Stamp  | 0001-01-01 00:00:00 |

| No.   | Time Stamp          | Ph Angle V Bn | Ph Angle V Ch | Ph Angle V BC | Ph Angle I A (0) | Ph Angle I B (0) | Ph Angle I C (0) | Ph Angle I A (0) | Ph Angle I B (0) | Ph Angle I C (0) |
|-------|---------------------|---------------|---------------|---------------|------------------|------------------|------------------|------------------|------------------|------------------|
| 12647 | 2019-08-20 11:41:00 | 107.7°        | 237.1°        | 0.0°          | 354.0°           | 113.9°           | 221.4°           | 0.0°             | 0.0°             | 0.0°             |
| 12648 | 2019-08-20 11:42:00 | 103.6°        | 234.0°        | 0.0°          | 351.1°           | 111.2°           | 226.4°           | 0.0°             | 0.0°             | 0.0°             |
| 12649 | 2019-08-20 11:43:00 | 103.1°        | 233.0°        | 0.0°          | 351.1°           | 111.2°           | 229.4°           | 0.0°             | 0.0°             | 0.0°             |
| 12650 | 2019-08-20 11:44:00 | 108.3°        | 236.0°        | 0.0°          | 354.0°           | 113.9°           | 229.4°           | 0.0°             | 0.0°             | 0.0°             |
| 12651 | 2019-08-20 11:45:00 | 103.7°        | 234.7°        | 0.0°          | 351.1°           | 111.2°           | 229.4°           | 0.0°             | 0.0°             | 0.0°             |
| 12652 | 2019-08-20 11:46:00 | 103.5°        | 232.7°        | 0.0°          | 351.1°           | 111.2°           | 226.4°           | 0.0°             | 0.0°             | 0.0°             |
| 12653 | 2019-08-20 11:47:00 | 103.8°        | 231.8°        | 0.0°          | 351.1°           | 111.2°           | 226.4°           | 0.0°             | 0.0°             | 0.0°             |
| 12654 | 2019-08-20 11:48:00 | 108.2°        | 236.7°        | 0.0°          | 354.0°           | 113.9°           | 226.4°           | 0.0°             | 0.0°             | 0.0°             |
| 12655 | 2019-08-20 11:49:00 | 107.9°        | 233.7°        | 0.0°          | 354.0°           | 113.9°           | 229.4°           | 0.0°             | 0.0°             | 0.0°             |
| 12656 | 2019-08-20 11:50:00 | 103.7°        | 233.9°        | 0.0°          | 351.1°           | 111.2°           | 229.4°           | 0.0°             | 0.0°             | 0.0°             |
| 12657 | 2019-08-20 11:51:00 | 104.1°        | 231.8°        | 0.0°          | 351.1°           | 111.2°           | 229.4°           | 0.0°             | 0.0°             | 0.0°             |
| 12658 | 2019-08-20 11:52:00 | 103.6°        | 234.5°        | 0.0°          | 351.1°           | 111.2°           | 229.4°           | 0.0°             | 0.0°             | 0.0°             |
| 12659 | 2019-08-20 11:53:00 | 105.7°        | 231.9°        | 0.0°          | 351.1°           | 111.2°           | 229.4°           | 0.0°             | 0.0°             | 0.0°             |
| 12660 | 2019-08-20 11:54:00 | 106.7°        | 231.9°        | 0.0°          | 351.1°           | 111.2°           | 226.4°           | 0.0°             | 0.0°             | 0.0°             |
| 12661 | 2019-08-20 11:55:00 | 106.7°        | 232.3°        | 0.0°          | 351.1°           | 113.9°           | 229.4°           | 0.0°             | 0.0°             | 0.0°             |
| 12662 | 2019-08-20 11:56:00 | 107.9°        | 236.5°        | 0.0°          | 354.0°           | 113.9°           | 229.4°           | 0.0°             | 0.0°             | 0.0°             |
| 12663 | 2019-08-20 11:57:00 | 108.1°        | 234.8°        | 0.0°          | 354.0°           | 113.9°           | 229.4°           | 0.0°             | 0.0°             | 0.0°             |
| 12664 | 2019-08-20 11:58:00 | 106.4°        | 237.4°        | 0.0°          | 354.0°           | 113.9°           | 229.4°           | 0.0°             | 0.0°             | 0.0°             |
| 12665 | 2019-08-20 11:59:00 | 107.2°        | 237.1°        | 0.0°          | 354.0°           | 113.9°           | 229.4°           | 0.0°             | 0.0°             | 0.0°             |
| 12666 | 2019-08-20 12:00:00 | 108.5°        | 236.1°        | 0.0°          | 354.0°           | 113.9°           | 231.4°           | 0.0°             | 0.0°             | 0.0°             |

Figure 4-23 - Data Log Retrieval Page

## 4.11 Time-of-Use (TOU)

Most utilities bill customers according to their Time-of-Use rates where customers are billed at certain rates depending on when the energy usage occurs. The Acuvim II meter supports a Time-of-Use functions that allows users to assign up to 4 different tariffs to different time periods within the day according to their billing requirements. The meter will calculate and accumulate energy to each of the different tariffs configured based on the meters time/date and TOU settings.

The Time-of-Use (TOU) must be configured from the Acuvim software by selecting **TOU** under the **Settings** tab.

### 4.11.1 General TOU Setting

- **Season Setting** - There can be a maximum of 12 seasons configured in the Acuvim II for the TOU settings. Each season will operate on the TOU Schedule it is configured to.
- **Schedule Setting** - There can be a maximum of 14 schedules. This parameter determines the number of TOU schedules available for the TOU calendar setting. Each schedule can be divided up into time segments and assigned a tariff.
- **Segment Setting** - A segment is included in a schedule and each schedule can have up to a maximum of 14 time segments. Each segment is assigned a tariff.

## Acuvim II Series Power Meter

- **Tariff Setting** - The Acuvim II supports up to 4 tariffs in the TOU function. The range is 0-3 for this setting where 0 means 1 tariff and 3 means all 4 tariffs are used.
  - 0 - Sharp
  - 1 - Sharp, Peak
  - 2 - Sharp, Peak, Valley
  - 3 - Sharp, Peak, Valley, Normal
- **Weekend Setting** - Allows users to assign which day(s) of the week to consider as weekends. The weekend setting can be set by making use of the following relationship where the 7 days of the week can be represented by 7 bits. The least significant bit (bit0) represents Sunday and bit1-bit6 represent Monday to Saturday.
  - A bit that is **0** represents the day is not a weekend
  - A bit that is **1** represents the day is a weekend
  - The decimal representation of the binary value is what is entered in the setting and the range is from 0-127. For example, to set Saturday and Sunday as weekend, the binary number would be 1000001, which is 65 in decimal.
- **Weekend Schedule** - If there are weekend settings, the user can configure which schedule to use for the weekend. Select the schedule number that is in reference to the weekend rates.
- **Holiday Setting** - A maximum of 30 holidays can be programmed to the TOU calendar. If the holiday setting parameter is set as 3, the first 3 slots of the holiday schedule must be set, otherwise, it will be considered as an invalid input (TOU function will be disabled).
- **Fault Status Word** - This will display a hex word if there is an error present in the TOU settings. This word should read 0 if all settings are correct. Table 4-4 explains the different error codes that can be displayed on the software. The Hex values are displayed in the Acuvim software.

Table 4-4 Fault Status Word Translation Table

| Error Code (Hex) | Error Code (Decimal) | Meaning of Error Code              |
|------------------|----------------------|------------------------------------|
| 0                | 0                    | Correct TOU settings               |
| 1                | 1                    | Tariff number setting error        |
| 4                | 4                    | Schedule setting Error             |
| 8                | 8                    | Season Setting Error               |
| A                | 10                   | Segment Setting Error              |
| C                | 12                   | Schedule Setting Error             |
| 10               | 16                   | Parameter of Season Setting Error  |
| 20               | 32                   | Holiday Number Setting Error       |
| 40               | 64                   | Parameter of Holiday Setting Error |

| Error Code (Hex) | Error Code (Decimal) | Meaning of Error Code                   |
|------------------|----------------------|---|
| 100              | 256                  | Tariff of Schedule Setting Error        |
| 200              | 512                  | Time of Schedule Setting Error          |
| 400              | 1024                 | Time sequence on schedule setting Error |
| 800              | 2048                 | Weekend Schedule Number Setting Error   |
| 1000             | 4096                 | Weekend Setting Error                   |

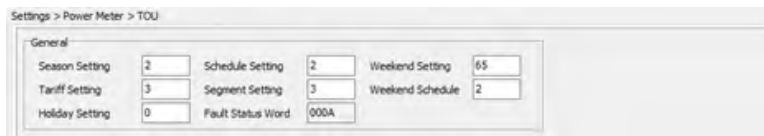

Figure 4-24 - TOU General Settings

#### 4.11.2 Monthly Billing Mode

Users can select the monthly billing that matches their billing requirement, where the billing mode can be at the end of every month or a specific time and date. The format for the time method is DD HH:MM:SS.

In this section, users can enable the TOU function in the Acuvim II meter by checking the box from the software. Users also have the option to restore the TOU setting back to its default settings from this section.

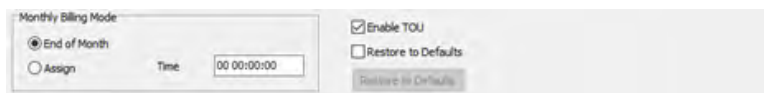

Figure 4-25 - TOU Monthly Billing Mode

#### 4.11.3 TOU Seasons

Enter the start date into the TOU season table slot following format **MM-DD ID**.

- MM stands for month (range is from 1 to 12)
- DD stands for date/day (range is from 1 to 31)
- ID represents the TOU schedule to run (range is from 1-14)

The dates should be organized so that they are in sequence according to the calendar year (the earlier date comes first and the later date comes last). For example, if 2 seasons are selected,

## Acuvim II Series Power Meter

the date parameters are March 31 and November 4, and TOU schedule 01, 02 will be used respectively, the first TOU season table slot shall enter 03-31 01, and the second slot shall enter 11-04 02. With this configuration the first season would be from March 31st to November 4th, and the second season would be from November 4th to March 31st.

**NOTE:** If the slot is filled incorrectly, the TOU function will be disabled

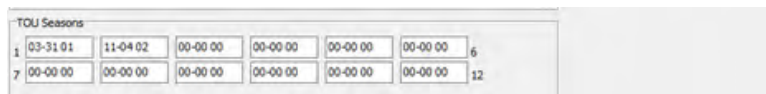

| TOU Seasons |          |          |          |          |          |          |    |
|-------------|----------|----------|----------|----------|----------|----------|----|
| 1           | 03-31 01 | 11-04 02 | 00-00 00 | 00-00 00 | 00-00 00 | 00-00 00 | 6  |
| 7           | 00-00 00 | 00-00 00 | 00-00 00 | 00-00 00 | 00-00 00 | 00-00 00 | 12 |

Figure 4-26 - TOU Season Configuration

### 4.11.4 TOU Schedule

The TOU Schedule Format can be seen in Figure 4-27, where each TOU schedule represents a 24-hour cycle. Similar to the TOU season format, enter the start time into the TOU schedule table slot following this format: HH:MM ID:

- HH stands for hour (range is in 24-hour format, 0 to 24 hours)
- MM stands for minutes (range is from 00 to 60 minutes)
- ID stands for tariffs (available from 00 to 03).

The time should be organized according to the hour sequence. For example, if 3 segments are configured, timing parameters are 01:00, 15:30, 22:45, the order of the 3 segments should be one of the following: 01:00, 15:30, 22:45 or 15:30, 22:45, 01:00 or 22:45, 01:00, 15:30. Entering time information in a wrong sequence (for example, entering 15:30, 01:00, 22:45) is considered as an invalid operation and the TOU function will be disabled.

In figure 4-27 below, TOU Schedule #1 can be described as follows:

- From 12AM to 11AM all energy consumed will be accumulate under the Sharp Tariff (Tariff ID 0)
- From 11AM to 5PM all energy consumed will be accumulated under the Peak Tariff (Tariff ID 1)
- From 5PM to 6PM all energy consumed will be accumulated under the Valley Tariff (Tariff ID 2)
- From 6PM to 8PM all energy consumed will be accumulated under the Normal Tariff (Tariff ID 3)
- From 8PM to 11AM all energy consumed will be accumulated under the Sharp Tariff (Tariff ID 0)

| TOU Schedule #1 |          |          |          |          |          |          |          |    |
|-----------------|----------|----------|----------|----------|----------|----------|----------|----|
| 1               | 00:00 00 | 11:00 01 | 17:00 02 | 18:00 03 | 20:00 00 | 00:00 00 | 00:00 00 | 7  |
| 8               | 00:00 00 | 00:00 00 | 00:00 00 | 00:00 00 | 00:00 00 | 00:00 00 | 00:00 00 | 14 |

| TOU Schedule #2 |          |          |          |          |          |          |          |    |
|-----------------|----------|----------|----------|----------|----------|----------|----------|----|
| 1               | 00:00 00 | 10:00 01 | 00:00 00 | 00:00 00 | 00:00 00 | 00:00 00 | 00:00 00 | 7  |
| 8               | 00:00 00 | 00:00 00 | 00:00 00 | 00:00 00 | 00:00 00 | 00:00 00 | 00:00 00 | 14 |

| TOU Schedule #3 |          |          |          |          |          |          |          |    |
|-----------------|----------|----------|----------|----------|----------|----------|----------|----|
| 1               | 00:00 00 | 00:00 00 | 00:00 00 | 00:00 00 | 00:00 00 | 00:00 00 | 00:00 00 | 7  |
| 8               | 00:00 00 | 00:00 00 | 00:00 00 | 00:00 00 | 00:00 00 | 00:00 00 | 00:00 00 | 14 |

Figure 4-27 - TOU Schedule Configuration

#### 4.11.5 Weekend Settings

**Weekends (Alternative):** In the case where a TOU schedule supports multiple schedules for a weekday or weekend within a season, the **Weekends (Alternative)** can be enabled to allow that day to run a specific schedule.

**NOTE:** If this feature is not enabled, the days configured as a weekend in the "Weekend Setting" will follow the "Weekend Schedule".

Each season can be configured to run an alternative schedule:

- Assign each season with the day(s) that will run the alternative schedule.
- Enter the decimal representation of the binary value for the days that will run the alternative schedule in the first column of the boxes in the setting. These boxes are numbered to represent each of the 12 seasons that can be configured for TOU. The decimal representation can be determined as follows (same as in the "Weekend Setting")

Recall that the weekend setting can be set by making use of the following relationship:

The 7 days of the week can be represented by 7 bits. The least significant bit (bit0) represents Sunday and bit1-bit6 represent Monday to Saturday.

- A bit that is 0 means the day is not considered as a weekend.
- A bit that is 1 means the day is considered as a weekend.

Next, for the days that are configured to run an alternative schedule, these days of the week will need to be assigned a schedule to run. In the second column, enter the schedule number (01-14) for each day that will run the alternative schedule. Sunday to Saturday are represented from left to right.

## Acuvim II Series Power Meter

**NOTE:** The days to fill in with the schedule number must correspond to the decimal representation set in the box to the left of this field.

| Weekends (Alternative) |    |                      |   |                      |    |
|------------------------|----|----------------------|---|----------------------|----|
| 1                      | 65 | 02,00,00,00,00,00,02 | 0 | 00,00,00,00,00,00,00 | 2  |
| 3                      | 0  | 00,00,00,00,00,00,00 | 0 | 00,00,00,00,00,00,00 | 4  |
| 5                      | 0  | 00,00,00,00,00,00,00 | 0 | 00,00,00,00,00,00,00 | 6  |
| 7                      | 0  | 00,00,00,00,00,00,00 | 0 | 00,00,00,00,00,00,00 | 8  |
| 9                      | 0  | 00,00,00,00,00,00,00 | 0 | 00,00,00,00,00,00,00 | 10 |
| 11                     | 0  | 00,00,00,00,00,00,00 | 0 | 00,00,00,00,00,00,00 | 12 |

Figure 4-28 - Weekends Alternative Setting

### 4.11.6 Holiday Settings

The Acuvim II supports holiday configuration within its TOU function, where a maximum of 30 holidays can be programmed to the TOU calendar. Users can program the amount of holidays within the TOU calendar by entering a number from 0-30 on the holiday setting in the General section of the TOU settings. For example if the holiday setting parameter is set as 3, the first 3 slots of the holiday schedule must be set, otherwise, it will be considered as an invalid input (TOU function will be disabled).

To configure the Holiday timing users must set the holiday schedule, which uses the same format as the TOU seasons MM-DD ID. Users can select which TOU schedule to be used for the holiday. The dates of the holiday schedule do not need to be organized in sequential order (i.e. the first slot can be January 1, the second slot can be December 26 and the third slot can be December 25).

| Holidays |          |          |          |          |          |          |    |
|----------|----------|----------|----------|----------|----------|----------|----|
| 1        | 12-25 04 | 05-24 04 | 11-11 01 | 00-00 00 | 00-00 00 | 00-00 00 | 6  |
| 7        | 00-00 00 | 00-00 00 | 00-00 00 | 00-00 00 | 00-00 00 | 00-00 00 | 12 |
| 13       | 00-00 00 | 00-00 00 | 00-00 00 | 00-00 00 | 00-00 00 | 00-00 00 | 18 |
| 19       | 00-00 00 | 00-00 00 | 00-00 00 | 00-00 00 | 00-00 00 | 00-00 00 | 24 |
| 25       | 00-00 00 | 00-00 00 | 00-00 00 | 00-00 00 | 00-00 00 | 00-00 00 | 30 |

Figure 4-29 - TOU Holiday Schedule Configuration

### Ten Year Holiday Setting

Users can preset holidays for the upcoming 10 years via the meter software. Since holiday dates change as the years go by, this feature allows users to preset the dates.

The holiday format is MM-DD ID, where the ID number is the schedule number to use for that holiday. Input all the holidays in the **Make Holiday Settings (10 year)** option located on the bottom of the page. Enter in the holiday dates, holiday code, and Schedule setting number. The holiday

codes are defined as follows:

- 0- Holiday only occurs once
- 1- Holiday occurs on the same date each year
- 2- Holiday occurs on the first Sunday on or after the date entered
- 3- Holiday occurs on the first Monday on or after the date entered
- 4- Holiday occurs on the first Thursday on or after the date entered
- 5- Holiday moved from Sunday to Monday
- 6- Holiday moved from Saturday to Friday or Sunday to Monday

Once all the holidays are entered in the TOU Holiday Code Settings, users can click on **Generate** to automatically populate and load all the holidays in the 10-year holiday settings. If the current year of the meter does not fall into the 10-year holiday setting, it remains as the current TOU settings.

**NOTE:** The holiday schedule has the highest priority among all the schedules. The weekend schedule's priority is followed by the Holiday schedule. When the holiday schedule is not enabled, the weekend schedule has the highest priority, overriding the normal (weekday) schedule.

Settings > Power Meter > Ten Years Holiday

Enable Holidays Years Settings

Start Year  Ending Year

1st Year Holidays

|    |          |          |          |          |          |          |    |
|----|----------|----------|----------|----------|----------|----------|----|
| 1  | 01-01 1  | 02-01 2  | 03-01 3  | 04-01 4  | 05-01 5  | 00-00 00 | 6  |
| 7  | 00-00 00 | 00-00 00 | 00-00 00 | 00-00 00 | 00-00 00 | 00-00 00 | 12 |
| 13 | 00-00 00 | 00-00 00 | 00-00 00 | 00-00 00 | 00-00 00 | 00-00 00 | 18 |
| 19 | 00-00 00 | 00-00 00 | 00-00 00 | 00-00 00 | 00-00 00 | 00-00 00 | 24 |
| 25 | 00-00 00 | 00-00 00 | 00-00 00 | 00-00 00 | 00-00 00 | 00-00 00 | 30 |

Settings Year  Holiday Number

2nd Year Holidays

|    |          |          |          |          |          |          |    |
|----|----------|----------|----------|----------|----------|----------|----|
| 1  | 01-01 1  | 02-01 2  | 03-01 3  | 04-01 4  | 05-01 5  | 06-01 6  | 6  |
| 7  | 07-01 7  | 08-01 8  | 09-01 9  | 10-01 10 | 00-00 00 | 00-00 00 | 12 |
| 13 | 00-00 00 | 00-00 00 | 00-00 00 | 00-00 00 | 00-00 00 | 00-00 00 | 18 |
| 19 | 00-00 00 | 00-00 00 | 00-00 00 | 00-00 00 | 00-00 00 | 00-00 00 | 24 |
| 25 | 00-00 00 | 00-00 00 | 00-00 00 | 00-00 00 | 00-00 00 | 00-00 00 | 30 |

Figure 4-30 - TOU 10 Years Holiday Configuration

Acuvim II Series Power Meter

TOU Holiday Code Definition

| Holiday Sched # | Actual Date (MM/DD/YYYY) | Holiday Code | Sched Setting | Holiday Sched # | Actual Date (MM/DD/YYYY) | Holiday Code | Sched Setting | Holiday Sched # | Actual Date (MM/DD/YYYY) | Holiday Code | Sched Setting |
|-----------------|--------------------------|--------------|---------------|-----------------|--------------------------|--------------|---------------|-----------------|--------------------------|--------------|---------------|
| 1.              | 12/25/2020               | 1            | 1             | 18.             | 00/00/2000               | 0            | 1             | 35.             | 00/00/2000               | 0            | 1             |
| 2.              | 05/24/2020               | 2            | 1             | 19.             | 00/00/2000               | 0            | 1             | 36.             | 00/00/2000               | 0            | 1             |
| 3.              | 00/00/2000               | 0            | 1             | 20.             | 00/00/2000               | 0            | 1             | 37.             | 00/00/2000               | 0            | 1             |
| 4.              | 00/00/2000               | 0            | 1             | 21.             | 00/00/2000               | 0            | 1             | 38.             | 00/00/2000               | 0            | 1             |
| 5.              | 00/00/2000               | 0            | 1             | 22.             | 00/00/2000               | 0            | 1             | 39.             | 00/00/2000               | 0            | 1             |
| 6.              | 00/00/2000               | 0            | 1             | 23.             | 00/00/2000               | 0            | 1             | 40.             | 00/00/2000               | 0            | 1             |
| 7.              | 00/00/2000               | 0            | 1             | 24.             | 00/00/2000               | 0            | 1             | 41.             | 00/00/2000               | 0            | 1             |
| 8.              | 00/00/2000               | 0            | 1             | 25.             | 00/00/2000               | 0            | 1             | 42.             | 00/00/2000               | 0            | 1             |
| 9.              | 00/00/2000               | 0            | 1             | 26.             | 00/00/2000               | 0            | 1             | 43.             | 00/00/2000               | 0            | 1             |
| 10.             | 00/00/2000               | 0            | 1             | 27.             | 00/00/2000               | 0            | 1             | 44.             | 00/00/2000               | 0            | 1             |
| 11.             | 00/00/2000               | 0            | 1             | 28.             | 00/00/2000               | 0            | 1             | 45.             | 00/00/2000               | 0            | 1             |
| 12.             | 00/00/2000               | 0            | 1             | 29.             | 00/00/2000               | 0            | 1             | 46.             | 00/00/2000               | 0            | 1             |
| 13.             | 00/00/2000               | 0            | 1             | 30.             | 00/00/2000               | 0            | 1             | 47.             | 00/00/2000               | 0            | 1             |
| 14.             | 00/00/2000               | 0            | 1             | 31.             | 00/00/2000               | 0            | 1             | 48.             | 00/00/2000               | 0            | 1             |
| 15.             | 00/00/2000               | 0            | 1             | 32.             | 00/00/2000               | 0            | 1             | 49.             | 00/00/2000               | 0            | 1             |
| 16.             | 00/00/2000               | 0            | 1             | 33.             | 00/00/2000               | 0            | 1             | 50.             | 00/00/2000               | 0            | 1             |
| 17.             | 00/00/2000               | 0            | 1             | 34.             | 00/00/2000               | 0            | 1             |                 |                          |              |               |

**Holiday code explain:**

- 0 - Holiday only occurs once
- 1 - Holiday same date each year
- 2 - First sunday on or after date
- 3 - First monday on or after date
- 4 - First thursday on or after date
- 5 - Holiday moved from Sun. to Mon.
- 6 - Holiday moved from Sat. to Fri. or Sun. to Mon.

Save Load Generate Close

Figure 4-31 - TOU Holiday Code Definition

#### 4.11.7 DST Settings

The Acuvim II series meter can adjust for the Daylight Savings Time and this function can be enabled from the Acuvim software. DST can be configured to follow one of two formats:

- 1. Fixed date option** - If you choose a fixed date option, you set the format according to a fixed date for the DST switch. The format is Month/ Day/ Hour/ Minute/ adjusted time (in minutes).
- 2. Non-Fixed date option** - If you choose the non-fixed option, DST will be implemented by which day of which week is selected. The format is Month/ Which Day/ Which Week/ Hour/ Minute/ adjusted time (in minutes).

Setting DST will cause the meter to automatically switch to and from daylight saving time. When the clock starts to follow daylight savings time, the meter will automatically adjust its clock to the new, correct time. When daylight savings time ends, the meter will automatically adjust again back to standard time.

Daylight Saving Time

DST Enable      DST Format: Format 1

Format 1

DST Start

Mar 31 Day 3 Hour 0 Min Adjust Time 60 Minutes

DST Ending

Nov 4 Day 3 Hour 0 Min Adjust Time 60 Minutes

Format 2

DST Start

Mar 1st Sun at 3:00 Adjust Time 60 Minutes

DST Ending

Nov 1st Sun at 3:00 Adjust Time 60 Minutes

Figure 4-32 - Daylight Savings Time Settings

#### 4.11.8 Reading the TOU data

Users can read the TOU data under the **Current Month TOU** option in the Readings tab. From here, users will be able to view all consumption for each tariff as well as the consumption total during the TOU period. Acuvim II can also record maximum power and current demand under different tariffs, as well as the timestamp of the maximum value. From here, the maximum demand value can be cleared for different tariffs.

## Acuvim II Series Power Meter

The Current Month TOU is divided into two sections: Accumulated and Incremental.

**Current Month TOU (Accumulated):** Refers to the TOU energy accumulated in the current month.

**Current Month TOU (Incremental):** Refers to the TOU energy accumulated in this month minus the TOU energy accumulated in the prior month.

Readings > Energy > Current Month TOU

| Current Month TOU (Accumulated) |             |            |            |            |             |
|---------------------------------|-------------|------------|------------|------------|-------------|
|                                 | Sharp       | Peak       | Valley     | Normal     | Total       |
| Ep_imp                          | 2025.3 kWh  | 4560.3 kWh | 1169.8 kWh | 1170.2 kWh | 12925.6 kWh |
| Ep_exp                          | 0.0 kWh     | 0.0 kWh    | 0.0 kWh    | 0.0 kWh    | 0.0 kWh     |
| Eq_imp                          | 0.0 kWh     | 0.0 kWh    | 0.0 kWh    | 0.0 kWh    | 0.0 kWh     |
| Eq_exp                          | 2503.9 kWh  | 1618.7 kWh | 409.1 kWh  | 412.1 kWh  | 4943.8 kWh  |
| Es                              | 11632.8 kWh | 7571.8 kWh | 1937.7 kWh | 1939.2 kWh | 23081.5 kWh |

| Current Month TOU (Incremental) |             |            |            |            |             |
|---------------------------------|-------------|------------|------------|------------|-------------|
|                                 | Sharp       | Peak       | Valley     | Normal     | Total       |
| Ep_imp                          | 2025.3 kWh  | 4560.3 kWh | 1169.8 kWh | 1170.2 kWh | 12925.6 kWh |
| Ep_exp                          | 0.0 kWh     | 0.0 kWh    | 0.0 kWh    | 0.0 kWh    | 0.0 kWh     |
| Eq_imp                          | 0.0 kWh     | 0.0 kWh    | 0.0 kWh    | 0.0 kWh    | 0.0 kWh     |
| Eq_exp                          | 2503.9 kWh  | 1618.7 kWh | 409.1 kWh  | 412.1 kWh  | 4943.8 kWh  |
| Es                              | 11632.8 kWh | 7571.8 kWh | 1937.7 kWh | 1939.2 kWh | 23081.5 kWh |

Figure 4-33 - Current Month TOU Readings

Maximum Demand

|            | Sharp                                 | Peak                                  | Valley                                | Normal                                | Total                                 |
|------------|---------------------------------------|---------------------------------------|---------------------------------------|---------------------------------------|---------------------------------------|
| Watt (imp) | 2.080 kW<br>2020-05-08<br>15:02:34    | 2.080 kW<br>2020-05-08<br>15:05:21    | 2.080 kW<br>2020-05-08<br>18:00:00    | 2.080 kW<br>2020-05-08<br>20:00:00    | 2.080 kW<br>2020-05-08<br>15:02:34    |
| Watt (exp) | 0.000 kW<br>2020-05-08<br>15:02:34    | 0.000 kW<br>2020-05-08<br>15:05:21    | 0.000 kW<br>2020-05-08<br>18:00:00    | 0.000 kW<br>2020-05-08<br>20:00:00    | 0.000 kW<br>2020-05-08<br>15:02:34    |
| VAR (imp)  | 0.000 kvar<br>2020-05-08<br>15:02:34  | 0.000 kvar<br>2020-05-08<br>15:05:21  | 0.000 kvar<br>2020-05-08<br>18:00:00  | 0.000 kvar<br>2020-05-08<br>20:00:00  | 0.000 kvar<br>2020-05-08<br>15:02:34  |
| VAR (exp)  | -0.800 kvar<br>2020-05-22<br>07:54:33 | -0.800 kvar<br>2020-05-21<br>14:37:15 | -0.720 kvar<br>2020-05-08<br>18:00:00 | -0.720 kvar<br>2020-05-08<br>20:00:00 | -0.800 kvar<br>2020-05-21<br>14:37:15 |
| VA         | 3.600 kVA<br>2020-05-19<br>08:17:23   | 3.600 kVA<br>2020-05-19<br>13:00:28   | 3.520 kVA<br>2020-05-08<br>18:00:00   | 3.520 kVA<br>2020-05-08<br>20:00:00   | 3.600 kVA<br>2020-05-19<br>08:17:23   |
| I A        | 5.040 A<br>2020-05-19<br>09:28:24     | 5.120 A<br>2020-05-21<br>14:52:16     | 4.960 A<br>2020-05-21<br>18:00:00     | 4.960 A<br>2020-05-19<br>21:04:35     | 5.120 A<br>2020-05-21<br>14:52:16     |
| I B        | 5.040 A<br>2020-05-19<br>09:26:24     | 5.120 A<br>2020-05-21<br>14:52:16     | 4.960 A<br>2020-05-19<br>19:32:34     | 4.960 A<br>2020-05-19<br>21:04:35     | 5.120 A<br>2020-05-21<br>14:52:16     |
| I C        | 5.040 A<br>2020-05-19<br>09:27:24     | 5.120 A<br>2020-05-21<br>14:52:16     | 4.960 A<br>2020-05-19<br>19:32:34     | 4.960 A<br>2020-05-19<br>21:04:35     | 5.120 A<br>2020-05-21<br>14:52:16     |

Clear Sharp    Clear Peak    Clear Valley    Clear Normal    Clear Total

Figure 4-34 - Peak Demand Readings

## Chapter 4: Detailed Functions and Software

The TOU function displays the prior month TOU readings from the Acuvue software. This allows users to compare the current month and previous month's readings for billing and analytical purposes. These readings can be viewed in the software by clicking on the **Prior Month TOU** option under the **Readings tab**. Similar to the current month, the prior month also allows users to view the Max Demand readings.

Readings > Energy > Prior Month TOU

| Prior Month TOU (Accumulated) |          |          |          |          |          |
|-------------------------------|----------|----------|----------|----------|----------|
|                               | Sharp    | Peak     | Valley   | Normal   | Total    |
| Ep_imp                        | 0.0 kWh  | 0.0 kWh  | 0.0 kWh  | 0.0 kWh  | 0.0 kWh  |
| Ep_exp                        | 0.0 kWh  | 0.0 kWh  | 0.0 kWh  | 0.0 kWh  | 0.0 kWh  |
| Eq_imp                        | 0.0 kVAh | 0.0 kVAh | 0.0 kVAh | 0.0 kVAh | 0.0 kVAh |
| Eq_exp                        | 0.0 kVAh | 0.0 kVAh | 0.0 kVAh | 0.0 kVAh | 0.0 kVAh |
| Es                            | 0.0 kWh  | 0.0 kWh  | 0.0 kWh  | 0.0 kWh  | 0.0 kWh  |

| Prior Month TOU (Incremental) |          |          |          |          |          |
|-------------------------------|----------|----------|----------|----------|----------|
|                               | Sharp    | Peak     | Valley   | Normal   | Total    |
| Ep_imp                        | 0.0 kWh  | 0.0 kWh  | 0.0 kWh  | 0.0 kWh  | 0.0 kWh  |
| Ep_exp                        | 0.0 kWh  | 0.0 kWh  | 0.0 kWh  | 0.0 kWh  | 0.0 kWh  |
| Eq_imp                        | 0.0 kVAh | 0.0 kVAh | 0.0 kVAh | 0.0 kVAh | 0.0 kVAh |
| Eq_exp                        | 0.0 kVAh | 0.0 kVAh | 0.0 kVAh | 0.0 kVAh | 0.0 kVAh |
| Es                            | 0.0 kWh  | 0.0 kWh  | 0.0 kWh  | 0.0 kWh  | 0.0 kWh  |

Figure 4-35 - Prior Month TOU Readings

| Prior Month Maximum Demand |                                      |                                      |                                      |                                      |                                      |
|----------------------------|--------------------------------------|--------------------------------------|--------------------------------------|--------------------------------------|--------------------------------------|
|                            | Sharp                                | Peak                                 | Valley                               | Normal                               | Total                                |
| Watt (imp)                 | 0.000 kW<br>2000-00-00<br>00:00:00   | 0.000 kW<br>2000-00-00<br>00:00:00   | 0.000 kW<br>2000-00-00<br>00:00:00   | 0.000 kW<br>2000-00-00<br>00:00:00   | 0.000 kW<br>2000-00-00<br>00:00:00   |
| Watt (exp)                 | 0.000 kW<br>2000-00-00<br>00:00:00   | 0.000 kW<br>2000-00-00<br>00:00:00   | 0.000 kW<br>2000-00-00<br>00:00:00   | 0.000 kW<br>2000-00-00<br>00:00:00   | 0.000 kW<br>2000-00-00<br>00:00:00   |
| VAR (imp)                  | 0.000 kvar<br>2000-00-00<br>00:00:00 | 0.000 kvar<br>2000-00-00<br>00:00:00 | 0.000 kvar<br>2000-00-00<br>00:00:00 | 0.000 kvar<br>2000-00-00<br>00:00:00 | 0.000 kvar<br>2000-00-00<br>00:00:00 |
| VAR (exp)                  | 0.000 kvar<br>2000-00-00<br>00:00:00 | 0.000 kvar<br>2000-00-00<br>00:00:00 | 0.000 kvar<br>2000-00-00<br>00:00:00 | 0.000 kvar<br>2000-00-00<br>00:00:00 | 0.000 kvar<br>2000-00-00<br>00:00:00 |
| VA                         | 0.000 kVA<br>2000-00-00<br>00:00:00  | 0.000 kVA<br>2000-00-00<br>00:00:00  | 0.000 kVA<br>2000-00-00<br>00:00:00  | 0.000 kVA<br>2000-00-00<br>00:00:00  | 0.000 kVA<br>2000-00-00<br>00:00:00  |
| IA                         | 0.000 A<br>2000-00-00<br>00:00:00    | 0.000 A<br>2000-00-00<br>00:00:00    | 0.000 A<br>2000-00-00<br>00:00:00    | 0.000 A<br>2000-00-00<br>00:00:00    | 0.000 A<br>2000-00-00<br>00:00:00    |
| IB                         | 0.000 A<br>2000-00-00<br>00:00:00    | 0.000 A<br>2000-00-00<br>00:00:00    | 0.000 A<br>2000-00-00<br>00:00:00    | 0.000 A<br>2000-00-00<br>00:00:00    | 0.000 A<br>2000-00-00<br>00:00:255   |
| IC                         | 0.000 A<br>2000-00-00<br>00:00:00    | 0.000 A<br>2000-00-00<br>00:00:00    | 0.000 A<br>2000-00-00<br>00:00:00    | 0.000 A<br>2000-00-00<br>00:00:00    | 10.20 A<br>2000-255-00<br>255:00:255 |

Figure 4-36 - Prior Month TOU Peak Demand Readings

## Acuvim II Series Power Meter

---

When setup appropriately and when TOU is enabled, energy will be accumulated on a month-to-month basis. The current energy usage will be stored under Current Month TOU (or Current Accumulation Month TOU) and is divided up into different tariffs. When the next month (or counting period) starts, all Current Month TOU values will be moved to the Prior Month TOU (or Prior Accumulation Month TOU).

The current month TOU will be reset depending on the billing method specified in the TOU settings, which can be either End of Month or Assigned Clock.

**1. End of Month:** This is the default method. All values from Current Month TOU (Accumulated) will be copied over to Prior Month TOU (Accumulated) at the very beginning of each month (the first day of each month at time 00:00:00). Current Accumulation Month TOU will continue to accumulate and all values from Current Month TOU will be copied over to Prior Month TOU at the very beginning of each month (the first day of each month at time 00:00:00) be cleared and reset to 0.

**2. Assigned Clock:** User can select when the values from Current Month TOU (Accumulated) or Current Month TOU would be copied over to Prior Month TOU (Accumulated) or Prior Month TOU. Users can set the time in the following format: **DD HH:MM:SS**, where **DD** stands for day, **HH** stands for hour, **MM** stands for minute, **SS** stands for second. Similar to the previous method, once Current Month TOU (Accumulated) is transferred to Prior Month TOU (Accumulated), Current Accumulation Month TOU will continue to accumulate. Once Current Month TOU is transferred to Prior Month TOU, Current Month TOU will be cleared and reset to 0.

### 4.12 Power Quality Event Logging and Waveform Capture

The Acuvim II meter supports a waveform capture function that allows users to monitor and record power quality events such as voltage swells, voltage sags, and over currents. This is very useful for users that are trying to track slow changing variation in electrical waveforms, and allows them to root out causes of mechanical equipment failure due to these power quality events.

Voltage sags and swells are the reduction(sag) and enlargement(swell) of voltage over a short time. Voltage sags are the most common events which can affect power quality significantly and are often the most costly. Power quality events such as voltage swells/sags affect equipment ranging from PLCs, relays, controllers and everything in between. When a voltage sag occurs the power supply inside most of these devices become over compensated and could potentially can damage the internal circuits of the device causing malfunctions. Although these are typically blamed on the utility the reality is these are often caused within the site and include grounding, bonding, and coding issues or from powering different equipment from the same supply.

**NOTE:** *If using 400Hz type Acuvim IIR, event logging and wave capture are not supported.*

### 4.12.1 Waveform Capture

The waveform capture function in the Acuvim IIW enables users to have the ability to capture 20 cycles of waveforms (10 cycles before and 10 cycles after the event) over three channels and log up to 100 groupings in the meters dedicated internal memory. The Acuvim IIW is the only model of the Acuvim II series that has 16MB of internal memory; 8MB is dedicated for the data logging function and another 8MB is dedicated for capturing power quality events.

The meter's waveform capture settings can be configured from the Acuvim software in the **Waveform** option under the **Settings** tab. Alternatively, the waveform settings can be configured by via the Modbus registers which are listed in Chapter 6 of the user manual.

**DI Triggering Waveform Capture:** The Acuvim II meter can be programmed to capture a waveform based on certain Digital Input settings including whether the DI has any change, from ON to OFF, or from OFF to ON.

Table 4-5 - DI Waveform Setting Translation

| DI Waveform Setting | DI Channel        | I/O Module |
|---------------------|-------------------|------------|
| DI 111 - DI 116     | Digital Input 1-6 | AXM-IO1-1  |
| DI 211 - DI 214     | Digital Input 1-4 | AXM-IO2-1  |
| DI 311 - DI 314     | Digital Input 1-4 | AXM-IO3-1  |

**NOTE:** The DI must be in Digital Status mode in order to be used for waveform triggering.

**Rated Voltage:** The rated voltage of the system should be entered here. The range is from 50-400V for wye systems or 50-690V for delta systems.

**Voltage Swell:** When any phase of the three-phase voltage is higher than the set value (voltage rated value x threshold %), there will be a voltage swell event. When a one phase voltage swell happens, the other phase will not respond to voltage swell event logging. Only once all of the phase voltages are restored back to normal will there be a response to a new voltage swell event.

- **Triggering Waveform Capture** - Check this box to enable voltage swell events.
- **Threshold** - Enter in the percentage of the voltage swell to be captured. The range is from 50-140%. For example, if the rated voltage is 277V and the voltage swell threshold is set for 110%, the swell event would be captured when the voltage is 110% above 277V, which is roughly 304V.

**Voltage Sag:** When any phase of the three-phase voltage is lower than the set value (voltage rated value x threshold %), there will be a voltage sag event. When a one phase voltage sag happens, the other phase will not respond to voltage sag event logging. Only once all of the phase voltages are restored back to normal will there be a response to a new voltage sag event.

- **Triggering Waveform Capture** - Select Enable to capture voltage sag events

## Acuvim II Series Power Meter

- **Threshold** - Enter in the percentage of the voltage sag to be captured. The range is from 20-100%. For example, if the rated voltage is 277V, and the voltage sag threshold is set for 50%, the sag event would be captured when the voltage drops 50% below 277V, which is roughly 138V.
- **Half-cycle Threshold** - Enter in the half cycle threshold for the sag event. The range is from 4-200 half cycles.

**NOTE:** The rated voltage setting is used for both Voltage Swell and Voltage Sag events

**Rated Current:** The rated current for the over current should be entered here and the range will be dependent on the CT1 value configured on the meter. The rated current range will be from 50-100% of the CT1 value. For example, if CT1 is configured as 1000A, the rated current range for the Power Quality event is from 500A to 1000A.

**Over Current:** Will trigger a waveform capture when the current is over the threshold configured. When over-current triggering is enabled, if any phase of the three-phase current is higher than the set value (rated value x threshold %), there will be an over current waveform captured by the Acuvim II meter. If one phase is over-current, any other phase over-current cannot implement the waveform capture. Only when all the phase currents are restored back to normal will waveform capture respond.

- **Triggering Waveform Capture** - Select enable to capture over current events
- **Threshold** - Enter in the percentage of the over current to be captured. The range is from 50-150%. For example, if the rated current is 1000A and the over current threshold is set for 50%, the over current event would be captured when the current is 50% of the rated current, which is 500A

Settings > Power Meter > Waveform

DI Triggering Waveform Capture

|                        |                    |                    |
|------------------------|--------------------|--------------------|
| DI 111: Any Change     | DI 112: Any Change | DI 113: Any Change |
| DI 114: Disabled       | DI 115: Disabled   | DI 116: Disabled   |
| DI 211: Disabled       | DI 212: Any Change |                    |
| DI 213: From OFF to ON | DI 214: Disabled   |                    |
| DI 311: Disabled       | DI 312: Disabled   |                    |
| DI 313: From ON to OFF | DI 314: Disabled   |                    |

Rated Voltage: 200 V      Rated Current: 5 A

**Voltage Swell**

Threshold: 100 %

Triggers Waveform Capture

Over-Current Triggering Waveform Capture

Threshold: 50 %

**Voltage Sag**

Level Threshold: 50 %

Half-cycle Threshold: 10 Half-cycle

Triggers Waveform Capture

Note: Voltage swells and voltage sags will trigger the event log.

Update Device

Figure 4-33 - Waveform Capture Settings

### 4.12.2 Power Quality Event Logging

When a power quality event happens, such as voltage sag and swell, Acuvim IIW will record the event timestamp and the triggering condition. It can save up to 50,000 events. The events can be viewed from Acuvim software in the **Events Log** located under the **Readings** tab.

The event log displays the newest even number and then allows users to view the events by either reading the latest 10 event records, the latest 50 event records, or 1000 records where users can enter in the starting record number. Once the record amount is set from the drop-down menu, click on **Read** to view the records in the event log.

The event log displays the record number, the timestamp (YYYY-MM-DD hh:mm:ss ms format) of when the event occurred, the reason for the event (sag or swell), the voltage rating, and the threshold configured as well as the half cycle configured.

The records can be saved either in text, .csv, or Excel format. Users can also clear the events log from Acuvim.

Once the event log reaches 50,000 events, no more events will be logged even if the triggering condition happens. The user must clear the event log to continue logging power quality events. Once the log is cleared, new events will be logged once an event occurs.

**NOTE:** The event log does not lose data when the power is shut off.

| No. | Time Stamp          | ms  | Reason                | Rating (V) | Threshold (...) | Half-cycle |
|-----|---------------------|-----|-----------------------|------------|-----------------|------------|
| 222 | 2020-04-09 18:17:39 | 515 | Voltage Sag (A/B)     | 200        | 20              | 10         |
| 223 | 2020-04-09 18:18:13 | 963 | Voltage Swell (A)     | 200        | 100             | 0          |
| 224 | 2020-04-09 18:20:30 | 569 | Voltage Swell (A/B/C) | 200        | 100             | 0          |
| 225 | 2020-04-09 18:20:42 | 432 | Voltage Swell (A/B/C) | 200        | 100             | 0          |
| 226 | 2020-04-09 18:21:23 | 800 | Voltage Sag (A/B/C)   | 200        | 50              | 10         |
| 227 | 2020-04-09 18:28:47 | 796 | Voltage Sag (A/B/C)   | 200        | 50              | 10         |
| 228 | 2020-04-14 10:18:47 | 604 | Voltage Sag (A/B/C)   | 200        | 50              | 10         |
| 229 | 2020-05-03 07:25:07 | 737 | Voltage Sag (A/B/C)   | 200        | 50              | 10         |
| 230 | 2020-05-19 00:28:53 | 140 | Voltage Sag (A/B/C)   | 200        | 50              | 10         |
| 231 | 2020-05-22 17:12:31 | 462 | Voltage Sag (A/B/C)   | 200        | 50              | 10         |

Figure 4-34 - Event Log Records

### 4.12.3 Waveform Retrieval

Once the power quality event is logged, users can retrieve the waveform from either the Acuvim software or by polling Modbus registers (discussed later in Chapter 6). In the Acuvim software, the waveform can be retrieved from the **Waveform Log** page under the **Readings** tab. Similar to the event log, the waveform log provides users with a log of all power quality events that occurred. Users can navigate and select which waveform record they wish to view, and the waveform can be read by clicking on the **Retrieve Waveform** button.

## Acuvim II Series Power Meter

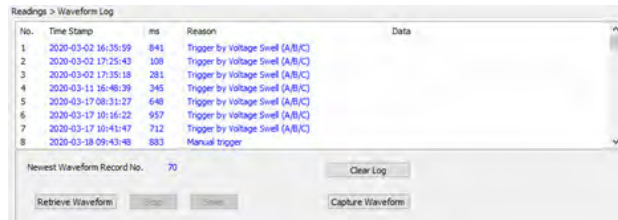

| No. | Time Stamp          | ms  | Reason                           | Data |
|-----|---------------------|-----|----------------------------------|------|
| 1   | 2020-03-02 16:35:59 | 841 | Trigger by Voltage Swell (A,B/C) |      |
| 2   | 2020-03-02 17:25:43 | 108 | Trigger by Voltage Swell (A,B/C) |      |
| 3   | 2020-03-02 17:35:18 | 281 | Trigger by Voltage Swell (A,B/C) |      |
| 4   | 2020-03-11 16:48:39 | 345 | Trigger by Voltage Swell (A,B/C) |      |
| 5   | 2020-03-17 08:31:27 | 648 | Trigger by Voltage Swell (A,B/C) |      |
| 6   | 2020-03-17 10:16:22 | 957 | Trigger by Voltage Swell (A,B/C) |      |
| 7   | 2020-03-17 10:41:47 | 712 | Trigger by Voltage Swell (A,B/C) |      |
| 8   | 2020-03-18 09:43:48 | 883 | Manual trigger                   |      |

Newest Waveform Record No. 70

Buttons: Retrieve Waveform, Clear Log, Capture Waveform

Figure 4-35 - Waveform Log

Users have the option to also manually capture a waveform on the Acuvim II meter, on the Acuvim software click on **Capture Waveform**. This may take 1-2 minutes to capture the waveform, and the waveform will show up in the Waveform Log with Reason description as Manual (refer to record number 8 in Figure 4-35 above). Manual capture allows users to capture and view the voltage and current waveform at any time once the meter is connected to the Acuvim software. This can be useful in comparing normal waveforms of the voltage and current with power quality event waveforms which show either voltage swell, sag or over current.

In the Waveform graph displayed on the Acuvim software, users can select which phases of voltage and current they want to view. The figure below displays only Phase B voltage and current waveforms. The Waveform Capture can log up to 100 groups of waveform data. Once the 100-group data is full, it does not respond to any waveform triggering condition. Only when all the waveform data is reset/emptied will the waveform capturing function resume. When the waveform data is emptied, new waveform data starts from the 1st group.

**NOTE:** Since the amount of each waveform group data is large, it takes more time to write into the flash memory. Therefore, Waveform Capture only responds to one triggering condition at one time. During the process of writing data into the flash memory, it does not respond to a new triggering condition. After the process of memory writing, it will respond to new waveform triggering conditions.

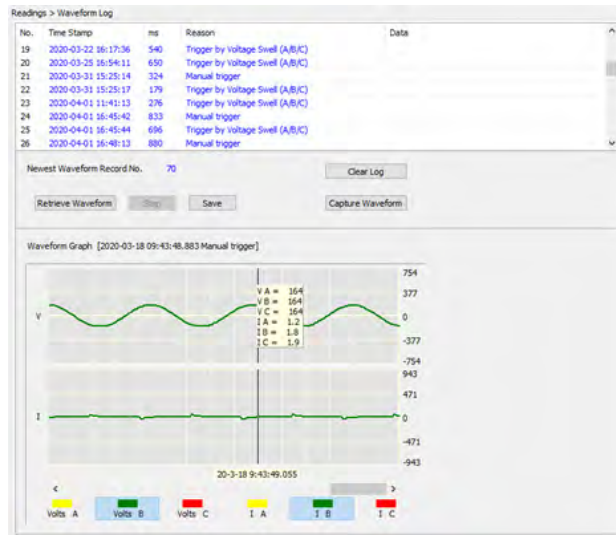

Figure 4-36 - Manual Capture Waveform

### Reading the Voltage and Current waveform

When the waveforms are displayed on the Acuvue software, the voltage and current are displayed as peak-to-peak values. In order to view the RMS values, users must convert the peak-to-peak values into RMS.

$$V_{rms} = \frac{V_{peak}}{\sqrt{2}}$$

For example, in Figure 4-37 the voltage for phase B reads 138. Converted to RMS, this value would be 97.58V (which is  $138/\sqrt{2}$ ).

The current is also displayed in peak values where the RMS current is calculated as follows:

$$I_{rms} = \frac{I_{peak}}{\sqrt{2}}$$

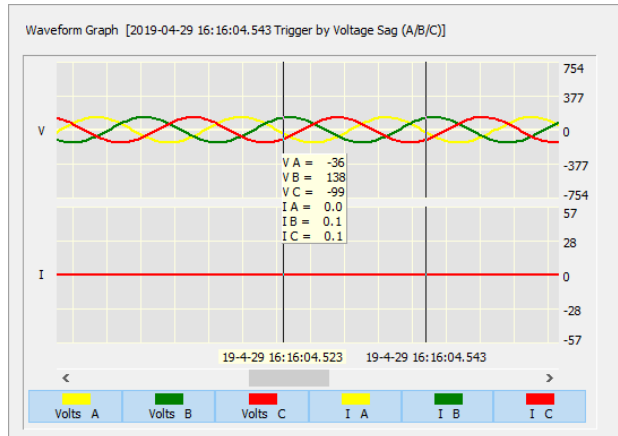

Figure 4-37 - Waveform Capture Retrieval Screen

### 4.13 Dual Source Energy

The Acuvim II series meters have bi-directional energy capability that allows users to control the direction (Grid/Generator) of the energy accumulation. The user can control the direction either by the Digital Input and through communication. There are two directions in which the energy can be changed to, "Grid" and "Generator".

Users can change the direction of the energy based on the Active Energy, Reactive Energy and Apparent Energy. Below is a table of that represents all options available for this feature.

Table 4-6 Bi-Directional Energy Parameters

| Parameters              | Config Option |
|-------------------------|---------------|
| Active Energy           | Ep            |
| Phase A Active Energy   | Epa           |
| Phase B Active Energy   | Epb           |
| Phase C Active Energy   | Epc           |
| Reactive Energy         | Eq            |
| Phase A Reactive Energy | Eqa           |
| Phase B Reactive Energy | Eqb           |
| Phase C Reactive Energy | Eqc           |
| Apparent Energy         | Es            |
| Phase A Apparent Energy | Esa           |
| Phase B Apparent Energy | Esb           |
| Phase C Apparent Energy | Esc           |

The bi-directional energy function can be enabled in the General Settings on the Acuvim software. Users can select the enabled option and configure the settings accordingly.

**Switching Mode:** Select the method in which the user wants to change the direction of the energy. Users can change the direction using the Digital Input (DI1-DI28), or they can use "Comm" control which changes the direction via Modbus register write to the control register.

**Metering Direction:** Can be selected as either "To Grid" or "To Generator".

**Energy 1/2/3:** Select the energy parameter desired, refer to table 4-6 for parameter list.

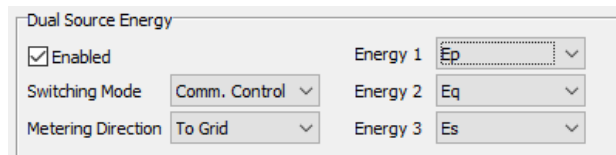

Figure 4-38 - Dual Source Energy Settings

#### 4.13.1 Controlling the Energy Direction

There are two methods to control the energy direction, either by communication or by the Digital Input. If the communication method is used, users must write to the Modbus energy direction register, see details of the register below.

Table 4-7 Dual Source Direction Register

| Address (H) | Address (D) | Parameter                       | Range                             | Data Type | Access Property |
|-------------|-------------|---------------------------------|-----------------------------------|-----------|-----------------|
| 1685H       | 5765        | Bi-Directional Energy Direction | 0: "To Grid"<br>1: "To Generator" | Word      | R/W             |

When DI1 ~ DI28 are selected as control input, the direction will be changed when the DI status is ON (High), and will change again when the status changes to OFF (Low). The following table lists the DI mapping from 1-28 with the corresponding I/O modules for the Acuvim II meter.

Table 4-8 DI Mapping for Dual Source Control Input

| I/O Module | DI Channel Mapping |
|------------|--------------------|
| AXM-IO11   | DI1-DI6            |
| AXM-IO21   | DI7-DI10           |
| AXM-IO31   | DI11-DI14          |
| AXM-IO12   | DI15-DI20          |
| AXM-IO22   | DI21-DI24          |
| AXM-IO32   | DI25-DI28          |

### 4.13.2 Bi-Directional Energy Switching Record

Whenever there is a change in direction for the energy, the Acuvim II meter will keep the historical changes in the Switching Record. The record supports 20 event records, and will overwrite from the earliest entry once the records reach the max amount. Users can reset the switch log and can also reset the dual source energy from Acuvim.

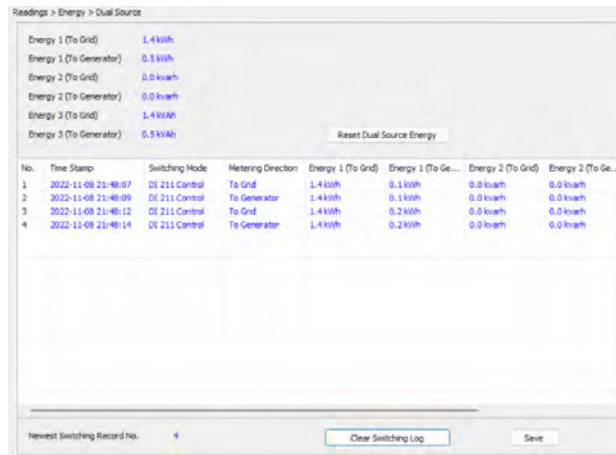

Figure 4-39 - Dual Source Energy Record

### 4.14 Seal Function

The Acuvim II supports a sealing function where the Acuvim II meter can be electronically sealed to prevent tampering of the meter settings or readings. The seal function can only be configured by writing to the Modbus registers and not from the meters display or Acuvim software. The register addressing for the seal function can be found in Chapter 6.

When the meter is sealed, some meter functions and certain parameters will be blocked. These parameters will still be accessible from the meter display or by Modbus however, they cannot be changed or modified.

**NOTE:** By default, the Acuvim II meter is not sealed.

## Chapter 4: Detailed Functions and Software

When the meter is in sealed status, the parameters listed in the tables below will be blocked.

**Table 4-9 System Parameters Settings blocked in Sealed Status**

| Parameters                              | Meter Display Keys | Modbus Communication |
|---|--------------------|----------------------|
| Voltage Input Wiring Mode               | √                  | √                    |
| Current Input Wiring Mode               | √                  | √                    |
| PT1(High 16 bit)                        | √                  | √                    |
| PT1(Low 16 bit)                         | √                  | √                    |
| PT2                                     | √                  | √                    |
| CT1                                     | √                  | √                    |
| CT2                                     | √                  | √                    |
| kWh pulse constant                      | √                  | √                    |
| kvarh pulse constant                    | √                  | √                    |
| Demand slide window time                | √                  | √                    |
| Demand calculating mode                 | √                  | √                    |
| Clear demand memory                     | √                  | √                    |
| Current I1 direction                    | √                  | √                    |
| Current I2 direction                    | √                  | √                    |
| Current I3 direction                    | √                  | √                    |
| VAR/PF convention                       | √                  | √                    |
| Energy clear                            | √                  | √                    |
| Energy Calculation Mode                 | √                  | √                    |
| Reactive Power Calculation Method       | √                  | √                    |
| Energy Display Mode                     | √                  | √                    |
| Basic Parameter Mode                    | √                  | √                    |
| Sealed Nonstandard Parameters Selection | ---                | √                    |

**NOTE:** “√” means these addresses will be blocked from the meter’s display keys and Modbus communication. The “-” symbol indicates this function is unavailable.

**Table 4-10 Energy Parameters Blocked in Sealed Status:**

| Parameters            | Meter Display Keys | Modbus Communication |
|-----------------------|--------------------|----------------------|
| Energy IMP            | ---                | √                    |
| Energy EXP            | ---                | √                    |
| Reactive energy IMP   | ---                | √                    |
| Reactive energy EXP   | ---                | √                    |
| Energy TOTAL          | ---                | √                    |
| Energy NET            | ---                | √                    |
| Reactive energy TOTAL | ---                | √                    |

## Acuvim II Series Power Meter

| Parameters                  | Meter Display Keys | Modbus Communication |
|-----------------------------|--------------------|----------------------|
| Reactive energy NET         | ---                | √                    |
| Apparent energy             | ---                | √                    |
| Phase A Energy IMP          | ---                | √                    |
| Phase A Energy EXP          | ---                | √                    |
| Phase B Energy IMP          | ---                | √                    |
| Phase B Energy EXP          | ---                | √                    |
| Phase C Energy IMP          | ---                | √                    |
| Phase C Energy EXP          | ---                | √                    |
| Phase A Reactive energy IMP | ---                | √                    |
| Phase A Reactive energy EXP | ---                | √                    |
| Phase B Reactive energy IMP | ---                | √                    |
| Phase B Reactive energy EXP | ---                | √                    |
| Phase C Reactive energy IMP | ---                | √                    |
| Phase C Reactive energy EXP | ---                | √                    |
| Phase A Apparent energy     | ---                | √                    |
| Phase B Apparent energy     | ---                | √                    |
| Phase C Apparent energy     | ---                | √                    |

Table 4-11 Digital Output Parameters blocked in Sealed Status

| Parameters                  | Meter Display Keys | Modbus Communication |
|-----------------------------|--------------------|----------------------|
| Working mode of DO1 and DO2 | √                  | √                    |
| DO pulse width              | √                  | √                    |
| DO1 output                  | √                  | √                    |
| DO2 output                  | √                  | √                    |
| Working mode of DO3 and DO4 | √                  | √                    |
| DO pulse width              | √                  | √                    |
| DO3 output                  | √                  | √                    |
| DO4 output                  | √                  | √                    |

### 4.14.1 Sealed Nonstandard Parameters

The following parameters are not sealed when the meter is in Sealed Status. However, they can be manually configured to be sealed. These non-standard parameters can be sealed from either the Acuvim software or by writing to the Modbus registers. From the Acuvim software, sealing can be configured from the **General** page under the **Settings** tab.

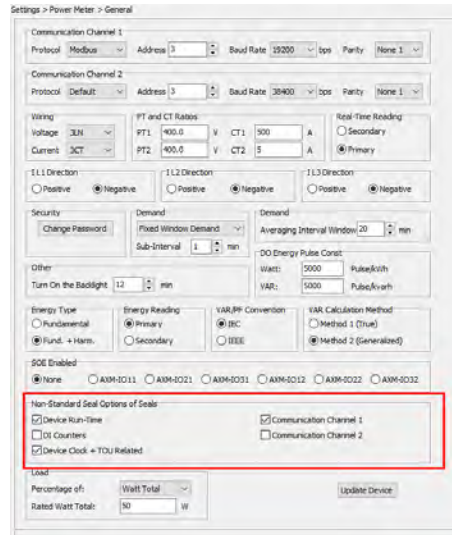

Figure 4-40 - Sealed Nonstandard Parameter Configuration

There are five categories that can be optionally sealed:

- Device Run Time
- DI Counters
- Device Clock & TOU
- Communication Channel 1
- Communication Channel 2

The following tables explain what functions are blocked if any of these are selected to be sealed.

Table 4-12 Run Time Clear in Sealed Status

| Parameters     | Meter Display Keys | Modbus Communication |
|----------------|--------------------|----------------------|
| Run time clear | √                  | √                    |

Table 4-13 DI Counter Functions Blocked in Sealed Status

| Parameters          | Meter Display Keys | Modbus Communication |
|---------------------|--------------------|----------------------|
| Pulse counter clear | √                  | √                    |
| DI1-6 type          | √                  | √                    |

## Acuvim II Series Power Meter

| Parameters        | Meter Display Keys | Modbus Communication |
|-------------------|--------------------|----------------------|
| DI pulse constant | √                  | √                    |
| DI7-10 type       | √                  | √                    |
| DI pulse constant | √                  | √                    |
| DI11-14 type      | √                  | √                    |
| DI pulse constant | √                  | √                    |
| DI15-20 type      | √                  | √                    |
| DI pulse constant | √                  | √                    |
| DI21-24 type      | √                  | √                    |
| DI pulse constant | √                  | √                    |
| DI25-28 type      | √                  | √                    |
| DI pulse constant | √                  | √                    |

Table 4-14 TOU Functions blocked in Sealed Status

| Parameters                               | Meter Display Keys | Modbus Communication |
|--|--------------------|----------------------|
| <b>TOU</b>                               |                    |                      |
| Ten years of download setting enabled    | ---                | √                    |
| Fee of sharp demand clear                | ---                | √                    |
| Fee of peak demand clear                 | ---                | √                    |
| Fee of valley demand clear               | ---                | √                    |
| Fee of normal demand clear               | ---                | √                    |
| Total fee of demand clear                | ---                | √                    |
| <b>Current and last month TOU energy</b> |                    |                      |
| Current and last month TOU energy        | ---                | √                    |
| <b>DST setting</b>                       |                    |                      |
| DST setting                              | ---                | √                    |
| <b>Season setting</b>                    |                    |                      |
| Basis parameter of TOU                   | ---                | √                    |
| Season setting                           | ---                | √                    |
| <b>Ten years of holiday setting</b>      |                    |                      |
| Ten years of holiday setting             | ---                | √                    |

Table 4-15 Communication Channel 1 Sealed Parameters

| Parameters              | Meter Display Keys | Modbus Communication |
|-------------------------|--------------------|----------------------|
| Run time clear          | √                  | √                    |
| Parity Setting 1        | √                  | √                    |
| Communication Address 1 | √                  | √                    |

Table 4-16 Communication Channel 2 Sealed Parameters

| Parameters                 | Meter Display Keys | Modbus Communication |
|----------------------------|--------------------|----------------------|
| Baud rate 2                | √                  | √                    |
| Parity setting 2           | √                  | √                    |
| Communication address 2    | √                  | √                    |
| <b>Ethernet Module</b>     |                    |                      |
| DHCP setting               | √                  | √                    |
| IP address 1st byte (high) | √                  | √                    |
| IP address 2nd byte (low)  | √                  | √                    |
| IP address 3rd byte (high) | √                  | √                    |
| IP address 4th byte (low)  | √                  | √                    |
| Submask 1st byte (high)    | √                  | √                    |
| Submask 2nd byte (low)     | √                  | √                    |
| Submask 3rd byte (high)    | √                  | √                    |
| Submask 4th byte (low)     | √                  | √                    |
| Gateway 1st byte (high)    | √                  | √                    |
| Gateway 2nd byte (low)     | √                  | √                    |
| Gateway 3rd byte (high)    | √                  | √                    |
| Gateway 4th byte (low)     | √                  | √                    |
| DNS1 1st byte (high)       | √                  | √                    |
| DNS1 2nd byte (low)        | √                  | √                    |
| DNS1 3rd byte (high)       | √                  | √                    |
| DNS1 4th byte (low)        | √                  | √                    |
| DNS2 1st byte (high)       | √                  | √                    |
| DNS2 2nd byte (low)        | √                  | √                    |
| DNS2 3rd byte (high)       | √                  | √                    |
| DNS2 4th byte (low)        | √                  | √                    |
| Modbus TCP/IP port         | √                  | √                    |
| HTTP port                  | √                  | √                    |
| <b>BACnet Module</b>       |                    |                      |
| BACnet module enable       | √                  | √                    |
| DHCP setting               | √                  | √                    |
| IP address 1st byte (high) | √                  | √                    |
| IP address 2nd byte (low)  | √                  | √                    |
| IP address 3rd byte (high) | √                  | √                    |
| IP address 4th byte (low)  | √                  | √                    |
| Submask 1st byte (high)    | √                  | √                    |
| Submask 2nd byte (low)     | √                  | √                    |
| Submask 3rd byte (high)    | √                  | √                    |
| Submask 4th byte (low)     | √                  | √                    |

## Acuvim II Series Power Meter

| Parameters              | Meter Display Keys | Modbus Communication |
|-------------------------|--------------------|----------------------|
| Gateway 1st byte (high) | √                  | √                    |
| Gateway 2nd byte (low)  | √                  | √                    |
| Gateway 3rd byte (high) | √                  | √                    |
| Gateway 4th byte (low)  | √                  | √                    |
| DNS1 1st byte (high)    | √                  | √                    |
| DNS1 2nd byte (low)     | √                  | √                    |
| DNS1 3rd byte (high)    | √                  | √                    |
| DNS1 4th byte (low)     | √                  | √                    |
| DNS2 1st byte (high)    | √                  | √                    |
| DNS2 2nd byte (low)     | √                  | √                    |
| DNS2 3rd byte (high)    | √                  | √                    |
| DNS2 4th byte (low)     | √                  | √                    |
| MAC address             | √                  | √                    |
| BACnet baud rate        | √                  | √                    |
| Max info frames         | √                  | √                    |
| BACnet Port             | √                  | √                    |
| <b>PROFIBUS Module</b>  |                    |                      |
| PROFIBUS address        | √                  | √                    |

## Chapter 5: Extended Modules

### 5.1 I/O Modules

The standard Acuvim II meter base does not have any built-in I/O functions. However, with the addition of the extended modules, multiple I/O options can be added. These functions include digital input status, pulse counter, relay output, analog output, and analog input. These I/O functions can be useful for a variety of metering applications such as counting/outputting pulse signals to/from water/gas meters, outputting 4-20mA analog signals to a PLC controller, or measuring the analog signal from a temperature sensor.

The Acuvim II series supports three types of I/O modules: the AXM-IO1, AXM-IO2 and AXM-IO3. There is a maximum of three external modules that can be attached to the Acuvim II meter, and this includes communication modules. If users have communication modules with I/O modules, the communication module is required to be installed on to the meter first, followed by the I/O modules. There can be no more than two of the same type of I/O module attached to the meter and, if there are two of the same type of I/O module connected to the meter, they must have a unique logic number. For example, if a user wants two AXM-IO2 modules, they will need to designate an AXM-IO2-1 and an AXM-IO2-2. In this case, the logic numbers for the modules are 1 and 2, respectively.

**NOTE:** When using a communications module with an I/O module, ensure that the communications module is installed on to the meter first.

#### 5.1.1 Appearance and Dimensions

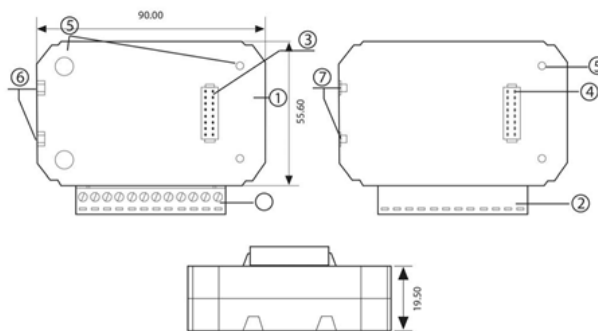

Figure 5-1 I/O Module Dimensions

Table 5-1 I/O Module Description Table

| Number | Description         |
|--------|---------------------|
| 1      | Enclosure           |
| 2      | Wiring Terminals    |
| 3      | Linking Pins        |
| 4      | Linking Socket      |
| 5      | Installation Screw  |
| 6      | Counterpart of Clip |
| 7      | Installation Clip   |

### 5.1.2 I/O Functionality

The AXM-IO1 module is composed of:



Figure 5-2 AXM-IO1 Module

- **6 Digital Inputs (DI)**

- Each digital input can be used in pulse counter or digital status mode. In digital status mode, the DI will be used to detect remote signals and the meter will log the time/date of the detection and store it in the SOE (sequence of events) log of the Acuvim II, if enabled. In pulse counter mode, the DI will be used to count digital pulses.
- Terminals **DI1** to **DIC** are the Digital Input terminals, where DIC is the common terminal for DI1-DI6 circuits.

- **2 Relay Outputs (RO)**

- The relay outputs can be used in two different modes, control mode or alarm mode, where both relays channels operate in the same mode. In control mode, users can configure the relay to work in either latch mode (ON/OFF) or momentary mode (ON/OFF for a certain time interval). When it operates in alarm mode, the relay will turn ON/OFF based on the status on the alarm configured in the Acuvim II meter.
- Terminals **RO1** to **ROC** are the Relay Output terminals, where ROC is the common terminal

for RO1 and RO2 circuits.

- **24Vdc Power Supply**

- Used as an auxiliary power supply for the digital input pulse circuits.
- The voltage of the DI auxiliary power supply is 24V(1W).
- Terminals **V+** and **V-** are the terminals for the 24Vdc power supply.

The **AXM-IO2** module is composed of:



Figure 5-3 AXM-IO2 Module

- **4 Digital Inputs (DI)**

- Each digital input can be used in pulse counter or digital status mode. In digital status mode, the DI will be used to detect remote signals where the meter will log the time/date of the detection and store it in the SOE (sequence of events) log of the Acuvim II, if enabled. In pulse counter mode, the DI will be used to count digital pulses.
- Terminals **DI1** to **DI-C** are the Digital Input terminals, where DI-C is the common terminal for DI1-DI4 circuits.

- **2 Analog Outputs (AO)**

- Depending on the model the AXM-IO2 can output an analog voltage or analog current based on certain parameters measures by the Acuvim II meter.
  - When it outputs analog voltage, the range of voltage is from 0 to 5V or from 1 to 5V.
  - When it outputs analog current, the range of current is from 0 to 20mA or from 4 to 20mA.
- Terminals **AO1+** to **AO2-** are the Analog Output terminals.

**NOTE:** The AXM-IO2 module can only output one type of analog signal.

- **2 Digital Outputs (DO)**

- The digital output can be used in either alarm mode or energy pulse output mode and both DO channels will operate in the same mode. In energy pulse mode, the DO will send digital pulses based on various types of energy (consumed/generated or real/reactive) reading

## Acuvim II Series Power Meter

measured by the Acuvim II meter. In alarm mode, the DO will output a digital pulse when an alarm is triggered.

- Terminals **DO1** to **DOC** are the Digital Output terminals, where **DOC** is the common terminals for **DO1** and **DO2**.

The **AXM-IO3** module is composed of:



Figure 5-4 AXM-IO3 Module

- **4 Digital Inputs (DI)**

- Each digital input can be used in pulse counter or digital status mode. In digital status mode, the DI will be used to detect remote signals and the meter will log the time/date of the detection and store it in the SOE (sequence of events) log of the Acuvim II, if enabled. In pulse counter mode, the DI will be used to count digital pulses.
- Terminals **DI1** to **DIC** are the Digital Input terminals, where **DIC** is the common terminal for **DI1**-**DI4** circuits.

- **2 Relay Outputs (RO)**

- The relay outputs can be used in two different modes, control mode or alarm mode, where both relay channels operate in the same mode. In control mode, users can configure the relay to work in either latch mode (ON/OFF) or momentary mode (ON/OFF for a certain time interval). When it operates in alarm mode, the relay will turn ON/OFF based on the status on the alarm configured in the Acuvim II meter.
- Terminals **RO1** to **ROC** are the Relay Output terminals, where **ROC** is the common terminal for **RO1** and **RO2** circuits.

- **2 Analog Inputs (AI)**

- Can detect input analog voltage or analog current.
  - When it detects input analog voltage, the range of voltage is from 0 to 5V or from 1 to 5V.
  - When it detects input analog current, the range of current is from 0 to 20mA or from 4 to 20mA.
- Terminals **AI1+** to **AI2-** are the Analog Input terminals.

**NOTE:** The AXM-IO3 can only read input from one type of analog signal.

Table 5-2 I/O Module Functionality Table

| Functions                   | AXM-IO1 | AXM-IO2 | AXM-IO3 |
|-----------------------------|---------|---------|---------|
| Detection of remote signals | •       | •       | •       |
| SOE Recording               | •       | •       | •       |
| Pulse Counting              | •       | •       | •       |
| Relay Control               | •       |         | •       |
| Relay Control by Alarm      | •       |         | •       |
| Digital Output by Alarm     |         | •       |         |
| Digital Pulse Output        |         | •       |         |
| Analog Output               |         | •       |         |
| Analog Input                |         |         | •       |
| 24Vdc Power Supply          | •       |         |         |

### 5.1.3 Installation Method

#### Environment

Please verify that the installation environment meets the following requirements:

#### Temperature:

Operation: -25°C to 70°C

Storage: -40°C to 85°C

#### Humidity:

5% to 95% non-condensing

#### Location:

The Acuvim II meter and I/O modules should be installed in a dry, dust-free environment away from heat, radiation, and high electrical noise/interference.

#### Installation Method:

Remove the **Ext. Port** cover from the back of the meter and any I/O module so that the linking pins are visible.

## Acuvim II Series Power Meter



Figure 5-5 External Port Cover

**NOTE:** Use a small, flat, thin screwdriver to remove the external port cover from the back of the meter.

1. Insert the counterpart clips of the module into the Acuvim II meter and then press the module down lightly to establish the linking.
2. Tighten the installation screws.
3. Install other modules using the steps above.

**NOTE:** Install modules carefully to avoid damage. Under no circumstances should any installation be done with the meter powered on. Failure to do so may cause damage to the meter.

**NOTE:** The maximum number of modules that can be attached to the meter is three. Ensure that any communication modules are installed prior to installing any I/O modules.

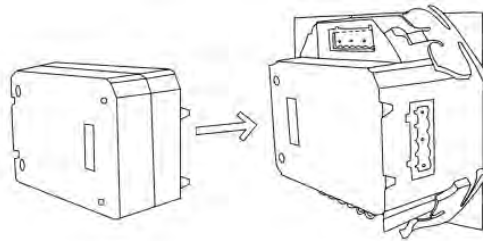

Figure 5-6 Installation of IO module to Acuvim II meter

### 5.1.4 I/O Module Wiring

#### Digital Input

##### Wiring of Digital Input Circuit:

There are six DI channels in the AXM-IO1 and four DI channels in the AXM-IO2 and AXM-IO3 modules. The Digital Input circuits within each of the modules are the same for both pulse counter and digital status modes. The digital input circuitry is described in Figure 5-6 below. From the wiring schematic, when K is open, OUT is in high state. When K is closed, OUT is in the low state.

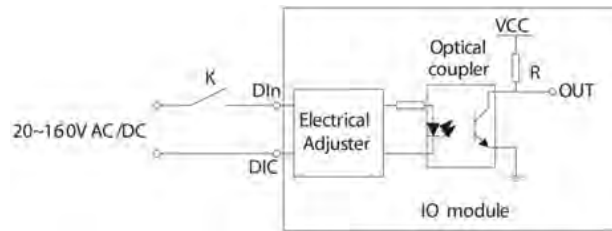

Figure 5-7 Digital Input Wiring Schematic

Digital Input ratings:

- External Power Supply Rating: 20-160Vac/Vdc
- Maximum loop current: 2mA
- Start Voltage: 15V
- Stop Voltage: 5V
- Max Pulse Frequency: 100Hz, 50% Duty Cycle (5ms ON and 5ms OFF)

#### Typical Digital Input Wiring

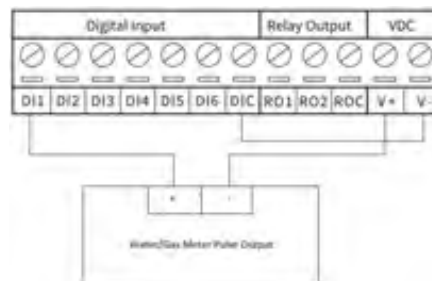

Figure 5-8 Digital Input pulse counter wiring using 24Vdc on AXM-IO1 module

## Acuvim II Series Power Meter

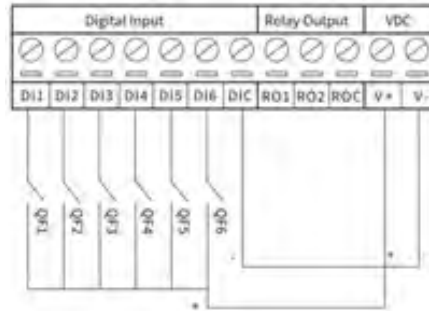

Figure 5-9 Multiple channel Digital Input wiring using 24Vdc on AXM-IO1 module

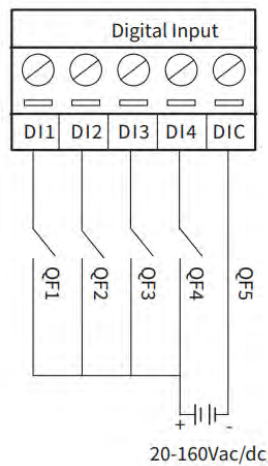

Figure 5-10 Digital Input Wiring Using AXM-IO2 and AXM-IO3 Modules

**NOTE:** The wire gauge to use with the DI should be between AWG22~16.

### Relay Output

There are two Relay Output channels in the AXM-IO1 and AXM-IO3 modules. The RO circuits can work in either control mode or alarm mode. The following diagram shows the schematic of the relay output circuit, which is the same regardless of the operating mode.

The relay type is a mechanical form A contact with 3A/250Vac or 3A/30Vdc. When using the relay output, it is recommended that an intermediate relay is used to control the output device.

Relay Output ratings:

- **Switching Voltage (Max):** 250Vac, 30Vdc
- **Load Current:** 5A (R), 2A (L)
- **Set Time:** 10ms (Max)
- **Contact Resistance:** 30mΩ (Max)
- **Isolation Voltage:** 2500Vac
- **Mechanical Life:** 1.5e7

#### Typical Relay Output Wiring

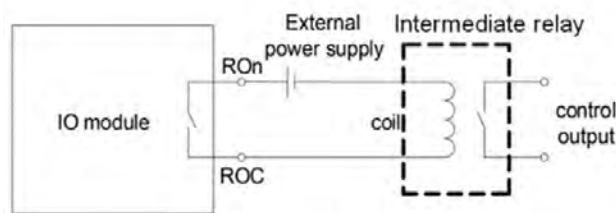

Figure 5-11 Relay Output Diagram

**NOTE:** The wire gauge to use with the relay output should be between AWG22~16.

#### Digital Output

There are two Digital Output channels on the AXM-IO2 module. The DO circuit can operate in either alarm mode or in energy pulse output mode.

The DO circuit is of Photo-MOS form. The simplified circuit is shown in Fig 5-11.

Digital Output ratings:

- **Voltage Range:** 0-250Vac/dc
- **Load Current:** 100mA (Max)
- **Output Frequency:** 25Hz, 50% Duty Ratio (20ms ON, 20ms OFF)
- **Isolation Voltage:** 2500Vac

## Acuvim II Series Power Meter

### Wiring of Digital Output Circuit

When the internal signal J is in the low state, OUT is also in a low state and, therefore, there is no pulse output. When J is in a high state, OUT is in the high state which will then output a pulse.

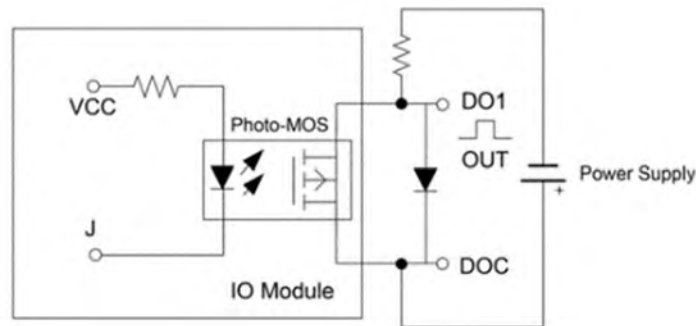

Figure 5-12 Digital Output Circuit

**NOTE:** The Digital Output is a dry contact and requires a voltage supply in order to generate the pulse signal.

The circuit for the alarm mode with a buzzer is shown in Figure 5-12.

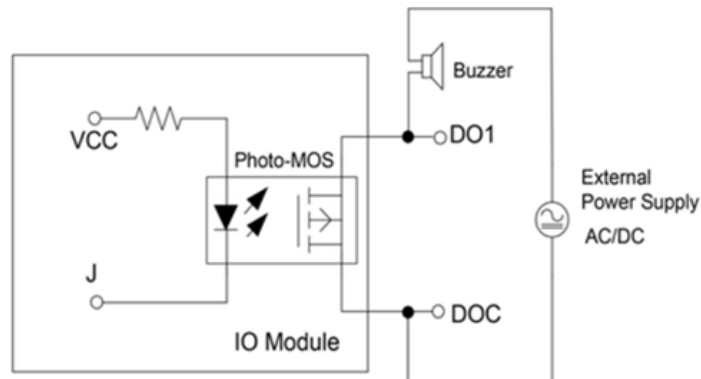

Figure 5-13 Digital Output as Alarm Mode

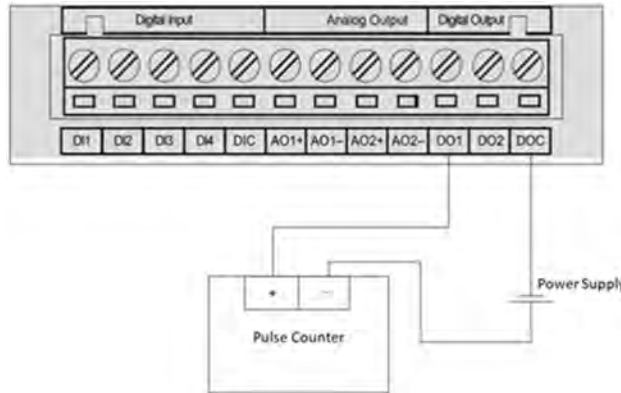

Figure 5-14 Digital Output to a pulse counter

**NOTE:** The power supply can be 0-250Vac/dc.

**NOTE:** The wire gauge to use for the DO should be between AWG22-16.

**Analog Output**

There are two Analog Output channels on the AXM-IO2 module. The AO circuit can convert metering parameters into an AO signal as either a voltage or current signal. One AXM-IO2 module supports either voltage or current where the AO circuit can provide either a 0-20mA or 4-20mA output or it can provide a 0-5V and 1-5V output.

**Wiring of Analog Output Circuit:**

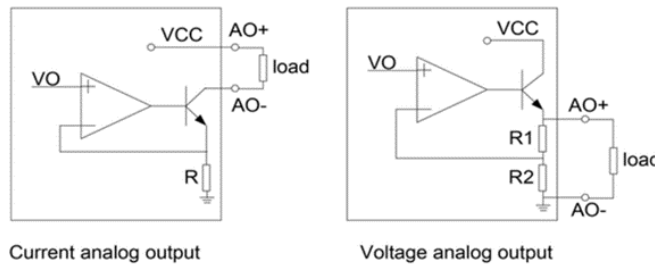

Figure 5-15 Analog Output circuit for voltage and current on AXM-IO2 module

## Acuvim II Series Power Meter

Analog Output Ratings:

- **For the current output (0-20mA/4-20mA):** The max load resistance is 500Ohms.
- **For the voltage output (0-5V/1-5V):** The max load current is 20mA.
- **Accuracy:** 0.5%
- **Temperature Drift:** 50ppm/°C Typical
- **Isolation Voltage:** 500Vdc
- **Open Circuit Voltage:** 15V

### Analog Input

#### Wiring of Analog Input Circuit:

There are two Analog Input channels on the AXM-IO3 modules. One AXM-IO3 module supports either voltage or current. The AI circuit can provide either a 0-20mA or 4-20mA input or it can provide a 0-5V and 1-5V input.

The simplified circuit is as shown in Fig 5-15

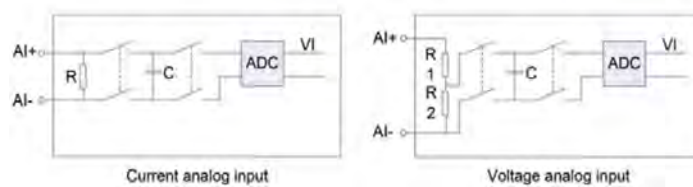

Figure 5-16 Analog Input Circuit for Voltage and Current on the AXM-IO3 Module

### 5.1.5 IO Module Readings

#### 5.1.6 Detection of Remote Signals

By default, the Digital Input on all I/O modules are configured in **State** mode, where the meter provides a digital signal status (ON/OFF). When the DI circuit detects a sufficient voltage input, it will show a **1** on the screen and **ON** from the Acuvim software. Otherwise, it will show a **0** on the screens and **OFF** on the software.

##### Viewing the Digital status from the Meters Display:

- Press **H** and **V/A** at the same time. The screen will go blank, and Meter will begin flashing.
- Press the **P** or **E** button to move the flashing cursor over to Digital I/O and press **V/A** to enter.
- Next, users will see the I/O selection screen, select the appropriate I/O module and press **V/A**.
- With the cursor on **DI**, press **V/A** to view the Digital Input Status readings.

**NOTE:** Refer to Chapter 3 section 3.7.4 on how to configure the DI from the meter's display.

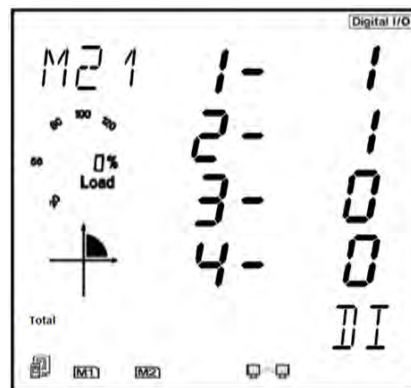

Figure 5-17 Digital Status Reading from Acuvim II Display

##### Viewing the Digital status from the Acuvim software:

The Digital Input mode can be configured from the Acuvim software, on the **I/O Modules \*1**, or **I/O Modules \*2** page under the **Settings** tab. The difference between I/O pages 1 and 2 is the module's logic number. For example, if users have an AXM-IO3-2, they will configure the settings on I/O Modules\*2.

## Acuvim II Series Power Meter

The DI settings must be set to **State** to monitor the Digital Status. If any changes are made to the I/O settings, click on **Update Device** at the bottom of the Settings page in order to save the configurations.

The image shows three configuration panels for digital input (DI) types. Each panel has a title and a grid of settings. In all panels, the 'State' radio button is selected for every DI channel, and the 'Counter' radio button is unselected.

- AXM-IO11:** DI 1 Type, DI 2 Type, DI 3 Type, DI 4 Type, DI 5 Type, DI 6 Type. All are set to State.
- AXM-IO21:** DI 1 Type, DI 2 Type, DI 3 Type, DI 4 Type. All are set to State.
- AXM-IO31:** DI 1 Type, DI 2 Type, DI 3 Type, DI 4 Type. All are set to State.

Figure 5-18 Digital Input Status Configuration

Under the **Readings** tab select either **I/O Modules \*1** or **I/O Modules \*2** depending on the I/O module's logic number. From there, users can see the digital input status on the software as either **ON** or **OFF**. Figure 5-18 shows the status of an AXM-IO2-1 module, where channels 1 and 2 have the status as ON and channels 3 and 4 have the status as OFF.

**NOTE:** AXM-IO11, AXM-IO21, and AXM-IO31 have logic number of 1. AXM-IO12, AXM-IO22, and AXM-IO32 have logic number of 2.

The screenshot displays the 'Readings > I/O Modules \*1' page. It shows three modules with their respective relay and digital input (DI) status. The AXM-IO21 module shows DI 1 and 2 as ON (red text) and DI 3 and 4 as OFF (green text). Analog output (AO) readings are also visible.

| Module   | Relay 1 | Relay 2 | DI 1 | DI 2 | DI 3 | DI 4 | DI 5 | DI 6 | AO 1     | AO 2     |
|----------|---------|---------|------|------|------|------|------|------|----------|----------|
| AXM-IO11 | OFF     | OFF     | OFF  | OFF  | OFF  | OFF  | OFF  | OFF  |          |          |
| AXM-IO21 |         |         | ON   | ON   | OFF  | OFF  |      |      | 3.999 mA | 3.999 mA |
| AXM-IO31 | OFF     | OFF     |      |      |      |      |      |      |          |          |

Figure 5-19 Digital Input Status Readings from the Acuvim Software

### Sequence of Events Record (SOE)

When the Digital Input is configured to detect remote signals, users have the option to monitor the digital status change using the sequence of events log on the Acuvim II meter. Users can select which I/O module to log from the **General** page under the **Settings** tab on the software. The SOE can also be enabled from the meter's display in the system settings of the Acuvim II meter. Refer to Chapter 3 of the manual for more details on configuring the settings from the display.

Users can select which module to record the status change events or can disable the SOE function by selecting **None**.

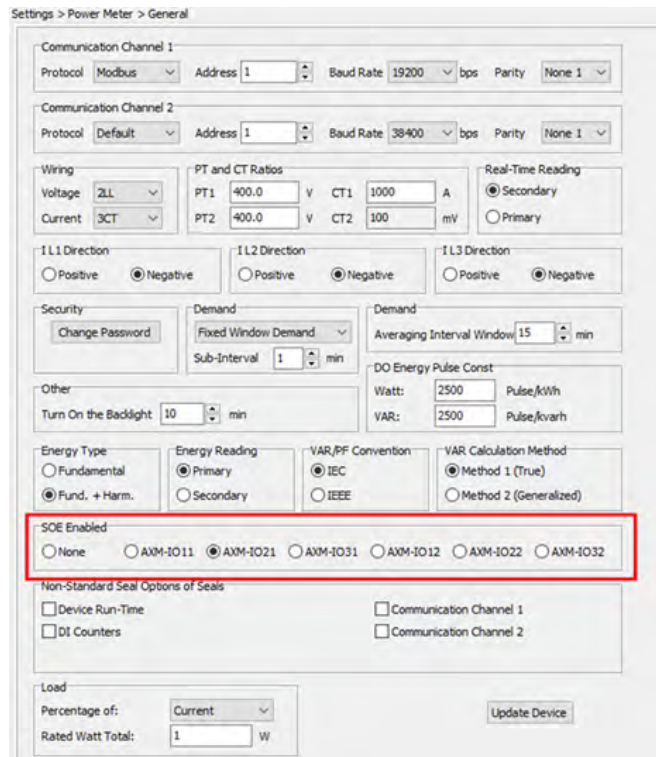

Figure 5-20 SOE Enable configuration

### SOE Records

The Sequence of Events log can record up to 20 events. When more than 20 events have been recorded, the SOE will overwrite the oldest record and continue recording. The SOE record includes the status from DI1-DI6 as well as the timestamp for when the change occurred.

## Acuvim II Series Power Meter

When the Acuvim II series meter is powered, the SOE will begin to record immediately. The data in the SOE Log is saved when the meter is powered down.

When a new I/O module is selected to be recorded from, the records will be overwritten immediately.

The SOE log can be read from the Acuvim software by selecting the **SOE Log** under the **Readings** tab.

**NOTE:** The Acuvim II meter will only log SOE events when the DI is configured for Status mode. If the DI is configured for pulse mode, there will be no change in the SOE Log.

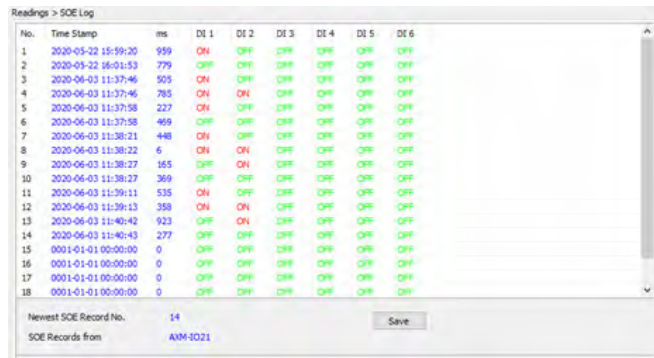

| No. | Time Stamp          | ms  | DI 1 | DI 2 | DI 3 | DI 4 | DI 5 | DI 6 |
|-----|---------------------|-----|------|------|------|------|------|------|
| 1   | 2020-05-22 15:59:30 | 959 | ON   | OFF  | OFF  | OFF  | OFF  | OFF  |
| 2   | 2020-05-22 16:01:53 | 779 | OFF  | OFF  | OFF  | OFF  | OFF  | OFF  |
| 3   | 2020-06-03 11:37:46 | 505 | ON   | OFF  | OFF  | OFF  | OFF  | OFF  |
| 4   | 2020-06-03 11:37:46 | 785 | ON   | ON   | OFF  | OFF  | OFF  | OFF  |
| 5   | 2020-06-03 11:37:58 | 227 | ON   | OFF  | OFF  | OFF  | OFF  | OFF  |
| 6   | 2020-06-03 11:37:58 | 469 | OFF  | OFF  | OFF  | OFF  | OFF  | OFF  |
| 7   | 2020-06-03 11:38:21 | 448 | ON   | OFF  | OFF  | OFF  | OFF  | OFF  |
| 8   | 2020-06-03 11:38:22 | 6   | ON   | ON   | OFF  | OFF  | OFF  | OFF  |
| 9   | 2020-06-03 11:38:27 | 165 | OFF  | ON   | OFF  | OFF  | OFF  | OFF  |
| 10  | 2020-06-03 11:38:27 | 369 | OFF  | OFF  | OFF  | OFF  | OFF  | OFF  |
| 11  | 2020-06-03 11:39:11 | 535 | ON   | OFF  | OFF  | OFF  | OFF  | OFF  |
| 12  | 2020-06-03 11:39:13 | 358 | ON   | ON   | OFF  | OFF  | OFF  | OFF  |
| 13  | 2020-06-03 11:40:42 | 923 | OFF  | ON   | OFF  | OFF  | OFF  | OFF  |
| 14  | 2020-06-03 11:40:43 | 277 | OFF  | OFF  | OFF  | OFF  | OFF  | OFF  |
| 15  | 0001-01-01 00:00:00 | 0   | OFF  | OFF  | OFF  | OFF  | OFF  | OFF  |
| 16  | 0001-01-01 00:00:00 | 0   | OFF  | OFF  | OFF  | OFF  | OFF  | OFF  |
| 17  | 0001-01-01 00:00:00 | 0   | OFF  | OFF  | OFF  | OFF  | OFF  | OFF  |
| 18  | 0001-01-01 00:00:00 | 0   | OFF  | OFF  | OFF  | OFF  | OFF  | OFF  |

Newest SOE Record No. 14  
SOE Records from AMM-0021

Figure 5-21 SOE Log Readings

### 5.1.7 Pulse Counter

The DI channels can also be configured to count pulses. Once the appropriate DI channel is configured to count pulses, the meter will be able to show this count on the meter display or from the Acuvim software.

#### Viewing the Digital Input pulse count from the Meters Display:

- Press **H** and **V/A** at the same time. The screen will go blank, and **Meter** will begin flashing.
- Press the **P** or **E** button to move the flashing cursor over to **Digital I/O** and press **V/A** to enter.
- Next, users will see the I/O selection screen. Select the appropriate I/O module and press **V/A**.
- Press either **P** or **E** to move the cursor down to **CTR** and press **V/A** to view the Digital Input Pulse Counter readings.
- Once on the Counter page, press **P** or **E** to navigate between different counters.

**NOTE:** Refer to section 3.7.4 in Chapter 3 for directions for configuring the DI from the meter's display.

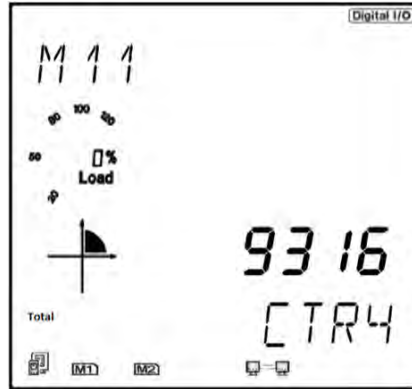

Figure 5-22 Digital Input Pulse Count from meters display

**NOTE:** The counter value is read from top to bottom on the meter display. For example, if the count value is 123456789, it will be displayed on the meter as 1 on the top line, 2345 on the second line, and 6789 on the bottom line.

**How to view and configure the Pulse Input from the Acuvview software:**

The Digital Input can be configured as Pulse Counter on the *I/O Modules \*1* or *I/O Modules \*2* page depending on the logic number of the module being configured. The DI mode must be set to **Counter** for the Digital Input to count the pulse signals. Users can also configure the pulse counter constant. This number represents how many pulses will equate to 1 count on the Digital Input; the range is from 1-65535.

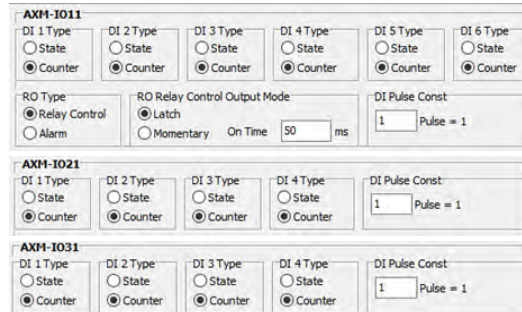

Figure 5-23 Pulse Counter configuration from Acuvview software

The DI pulse count data can be read on the Acuvview software from the **Readings** tab by selecting either *I/O Modules \*1* or *I/O Modules \*2* depending on the logic address of the module that is connected to the meter.

## Acuvim II Series Power Meter

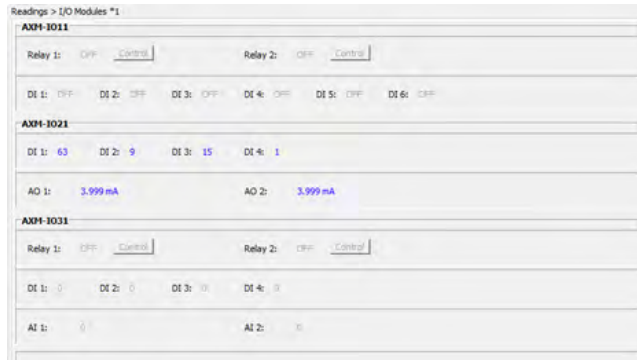

Fig 5-24 Pulse Counter Readings from the Acuvim software

### Scaling Pulse Count Values

The pulse count can be scaled from the Acuvim software. This allows users to scale or multiply the raw pulse count values and can be useful when converting pulse counts from a water or gas meter. To configure, go to **Pulse Input** under the **Settings tab**. From here, users will have the option to configure the Name, the Category, unit, and ratio multiplier.

Users can select the options from the drop-down menu under Category and Unit. However, if the required category/unit is not available, users can create their own by clicking on the **Advanced Options** button at the bottom of the page. Refer to Figure 5-24 for the Advanced Options.

Once all values have been entered, click on **Apply** to save the settings.

| DI Name | DI Type | Name          | Category | Unit | Ratio |
|---------|---------|---------------|----------|------|-------|
| DI_111  | State   |               |          |      | 1     |
| DI_112  | State   |               |          |      | 1     |
| DI_113  | State   |               |          |      | 1     |
| DI_114  | State   |               |          |      | 1     |
| DI_115  | State   |               |          |      | 1     |
| DI_116  | State   |               |          |      | 1     |
| DI_211  | Counter | Water Meter 1 | Water    | mL   | 0.5   |
| DI_212  | Counter | Gas Meter     | Gas      | m3   | 0.33  |
| DI_213  | Counter | Counter       | Energy   | \$   | 12    |
| DI_214  | Counter | Test          |          | kWh  | 1     |
| DI_311  | Counter |               |          |      | 1     |
| DI_312  | Counter |               |          |      | 1     |

Figure 5-25 Pulse Input Scaling from Acuvim software

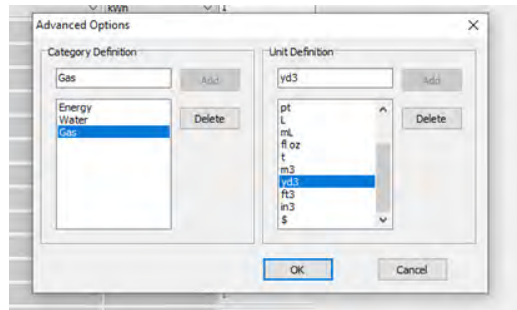

Figure 5-26 Pulse Category/Unit configuration

To view the scaled pulse input readings, go to **Real-Time** under **Energy** in the **Readings** tab. The multiplied pulse count values will be displayed in the Pulse Input table.

| Name          | Category | Reading | Unit           |
|---------------|----------|---------|----------------|
| Water Meter 1 | Water    | 31.5    | mL             |
| Gas Meter     | Gas      | 2.97    | m <sup>3</sup> |
| Counter       | Energy   | 100     | \$             |
| Test          |          | 1       | kWh            |

Figure 5-27 Scaled Pulse Input Readings

**NOTE:** These scaled readings will only be displayed on the Acuvue software. The readings from the meter's display, Modbus registers, and I/O readings page on Acuvue will only display the raw count value.

### Clearing the Pulse Count

The pulse count can be cleared from the meter's display, Acuvue software, or by Modbus registers. For directions on how to clear the pulse count using the meter's display, refer to Chapter 3. For Modbus directions, refer to Chapter 6.

To clear the pulse count from the Acuvue software, go to the **Pulse Input** page under the **Settings** tab. At the bottom of the page, use the drop-down menu to select which I/O module DI count to clear. Once selected, click on **Reset DI Counters**.



Figure 5-28 Reset DI Counter from Acuvue software

### 5.1.8 Relay Output

The relay output is supported on the AXM-IO1 and AXM-IO3 modules. Users can read the relay output status from either the meter's display, Acuvim software, or through Modbus registers.

#### Reading Relay Output from Meter Display:

- Press **H** and **V/A** at the same time. The screen will go blank and **Meter** will begin flashing.
- Press the **P** or **E** button to move the flashing cursor over to **Digital I/O** and press **V/A** to enter.
- Next users will see the I/O selection screen, select the appropriate I/O module and press **V/A**.
- Press either **P** or **E** to move the cursor down to **RO** and press **V/A** to view the Digital Input Pulse Counter readings.

By default, the relay will be in **OFF** state (normally open). When the relay output is triggered, the relay status will switch to **ON**.



Figure 5-29 Relay Output Status Readings

#### How to view and configure the Relay Output from the Acuvim software:

The Relay Output settings can be configured from the Acuvim software on the **I/O Modules \*1** or **I/O Modules \*2** page under the **Settings** tab depending on the logic number of the I/O module being used. There are two RO types that the module can be configured as:

- **Relay Control:** When configured as relay control, users can manually switch the relay ON/OFF. There are two additional modes, if the relay is set for Relay Control: Latch and Momentary.

- **Latch:** When the control mode is set for Latch, the relay will only be switched ON/OFF manually by the user.
- **Momentary:** When the control mode is set for Momentary, the relay will only switch ON for certain time period which can be configured by user. The range for this time period is from 50-3000ms.
- **Alarm:** When configured as alarm, the relay will switch ON/OFF based on the alarm condition set in the Acuvim II meter. Users can configure a certain alarm to trigger the relay if its value is over/under a certain condition.



Figure 5-30 Relay Output Configuration from Acuvim Software

Settings > Power Meter > Alarm

Enable Alarm     Enable Backlight Flashing    Update Device

| Limit ID | Enable                              | Alarm Channel          | Setting | Setpoint | Delay (ms) | AND | DO211                    | DO212                    | DO221                    | DO222                    | RO*** |
|----------|-------------------------------------|------------------------|---------|----------|------------|-----|--------------------------|--------------------------|--------------------------|--------------------------|-------|
| #1       | <input checked="" type="checkbox"/> | Frequency (Hz)         | <       | 60       | 0          |     | <input type="checkbox"/> | <input type="checkbox"/> | <input type="checkbox"/> | <input type="checkbox"/> | 112   |
| #2       | <input checked="" type="checkbox"/> | Watt A (kW)            | >       | 250.0    | 0          |     | <input type="checkbox"/> | <input type="checkbox"/> | <input type="checkbox"/> | <input type="checkbox"/> | 111   |
| #3       | <input type="checkbox"/>            | Volts AN (V)           | >       | 100.0    | 0          |     | <input type="checkbox"/> | <input type="checkbox"/> | <input type="checkbox"/> | <input type="checkbox"/> |       |
| #4       | <input type="checkbox"/>            | I A (A)                | <       | 10.00    | 0          |     | <input type="checkbox"/> | <input type="checkbox"/> | <input type="checkbox"/> | <input type="checkbox"/> |       |
| #5       | <input type="checkbox"/>            | Frequency (Hz)         | >       | 0.00     | 0          |     | <input type="checkbox"/> | <input type="checkbox"/> | <input type="checkbox"/> | <input type="checkbox"/> |       |
| #6       | <input checked="" type="checkbox"/> | DI 212                 | =       | 25       | 0          |     | <input type="checkbox"/> | <input type="checkbox"/> | <input type="checkbox"/> | <input type="checkbox"/> |       |
| #7       | <input type="checkbox"/>            | Reverse Phase Sequence |         |          | 0          |     | <input type="checkbox"/> | <input type="checkbox"/> | <input type="checkbox"/> | <input type="checkbox"/> |       |
| #8       | <input type="checkbox"/>            | Frequency (Hz)         | >       | 0.00     | 0          |     | <input type="checkbox"/> | <input type="checkbox"/> | <input type="checkbox"/> | <input type="checkbox"/> |       |
| #9       | <input type="checkbox"/>            | Frequency (Hz)         | >       | 0.00     | 0          |     | <input type="checkbox"/> | <input type="checkbox"/> | <input type="checkbox"/> | <input type="checkbox"/> |       |
| #10      | <input type="checkbox"/>            | Frequency (Hz)         | >       | 0.00     | 0          |     | <input type="checkbox"/> | <input type="checkbox"/> | <input type="checkbox"/> | <input type="checkbox"/> |       |
| #11      | <input type="checkbox"/>            | Frequency (Hz)         | >       | 0.00     | 0          |     | <input type="checkbox"/> | <input type="checkbox"/> | <input type="checkbox"/> | <input type="checkbox"/> |       |
| #12      | <input checked="" type="checkbox"/> | Watt Demand (kW)       | >       | 75.00    | 0          |     | <input type="checkbox"/> | <input type="checkbox"/> | <input type="checkbox"/> | <input type="checkbox"/> |       |
| #13      | <input type="checkbox"/>            | Frequency (Hz)         | >       | 0.00     | 0          |     | <input type="checkbox"/> | <input type="checkbox"/> | <input type="checkbox"/> | <input type="checkbox"/> |       |
| #14      | <input type="checkbox"/>            | Frequency (Hz)         | >       | 0.00     | 0          |     | <input type="checkbox"/> | <input type="checkbox"/> | <input type="checkbox"/> | <input type="checkbox"/> |       |
| #15      | <input type="checkbox"/>            | Frequency (Hz)         | >       | 0.00     | 0          |     | <input type="checkbox"/> | <input type="checkbox"/> | <input type="checkbox"/> | <input type="checkbox"/> |       |
| #16      | <input type="checkbox"/>            | Frequency (Hz)         | >       | 0.00     | 0          |     | <input type="checkbox"/> | <input type="checkbox"/> | <input type="checkbox"/> | <input type="checkbox"/> |       |

Figure 5-31 Alarm relay trigger configuration from Acuvim software.

To read the status of the relay output from the Acuvim software, click on either the **I/O Modules \*1** or **I/O Modules \*2** page under the **Readings** tab depending on the logic number of the I/O module being used. The relay status will read **ON** when the relay switch is closed and will read **OFF** when the relay switch is open.

If the relay is in Control Mode, users can manually turn the relay ON/OFF from the Acuvim software by clicking on the **Control** button. Users will be prompted to enter the password of the meter (**0000** by default) in order to control the relay output.



Figure 5-32 Relay Output Readings from Acuvim Software

### 5.1.9 Digital Output

The AXM-IO2 module supports the Digital Output and has two digital output channels that can be configured for either Alarm mode or Energy Pulse mode. The DO can be configured from the meter's display (refer to Chapter 3), from the Acuvim software, or from the Modbus registers (refer to Chapter 6).

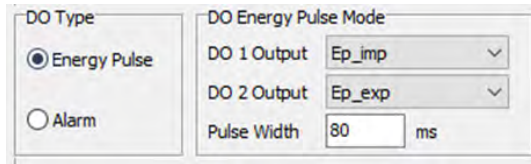

Figure 5-33 Digital Output Configuration from Acuvim Software

- **Energy Pulse:** In energy pulse mode, the DO will send pulses based on the energy accumulation that the meter is measuring. When selected, users can configure DO 1 and 2 Output to one of the following:
  - **Ep\_imp:** Import Energy
  - **Ep\_exp:** Export Energy
  - **Eq\_imp:** Import Reactive Energy
  - **Eq\_exp:** Export Reactive Energy
- **Pulse Width:** Users can configure the pulse width from 20-1000ms; the default is 80ms.
- **Alarm:** When configured in alarm mode, the module will send a pulse signal whenever an alarm is triggered.

Whenever the meter sends a pulse signal, a pulse icon can be seen on the meter's display. This icon will flash whenever a pulse signal is sent out from the digital output. Figure 5-33 shows where and how the pulse signal indicator is displayed.

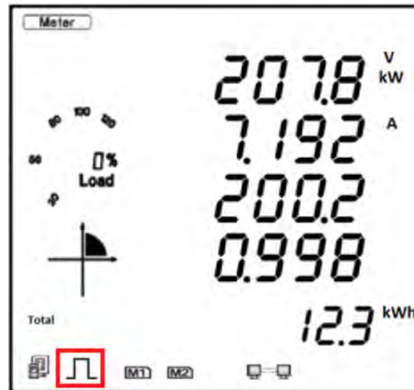

Figure 5-34 Pulse Signal Indicator on meter's display

#### Digital Output Pulse Constant Configuration

If the DO is configured for Energy Pulse Output mode, users will need to configure the pulse constant so that the meter will know how often to send a pulse signal out. In order to determine the correct pulse constant, users must know the rated current and rated voltage of their system. Below is an example on how to manually calculate the pulse constant.

#### Manual Pulse Constant Calculator:

The pulse constant must be configured in order for the meter to output the pulses accurately.

The following shows how to calculate the pulse constant manually:

- Determine how many pulses represent 1kWh or how many kWh represents 1 pulse.

*Example 1 pulse = 1 kWh*

- Multiply the PT ratio and CT ratio i.e.,  $PT1/PT2 * CT1/CT2$

*Example: PT ratio is 6600V/120V, and the CT ratio is 2000:5A.*

$$\left(\frac{6600}{120}\right) \times \left(\frac{2000}{5}\right) = 22,000$$

**NOTE:** If no PTs were used, enter the default PT ratio of 400/400. If the CT2 output is 333mV, RCT, or 80/100/200mA use 1 as the CT2 value.

- Divide 1kWh by 22,000 i.e.,  $(1/22000)$  kWh

## Acuvim II Series Power Meter

- This means 1 pulse = (1/22000) kWh; therefore 22000 pulses = 1 kWh
- Since we get 22000 pulse/kWh, 22000 is the pulse constant.

Once the pulse constant value has been calculated, users can configure the pulse constant setting from the setting menu in the meter display (refer to Chapter 3), via Modbus registers (refer to Chapter 6), or Acuvim software.

In the Acuvim software, users can configure the pulse constant by clicking on the **General** page under the **Settings** tab. Users can configure the pulse constant for either real energy (Pulse/kWh) or reactive energy (Pulse/kvarh).

The screenshot shows the 'Settings > Power Meter > General' configuration page. The 'DO Energy Pulse Const' section is highlighted with a red box, containing the following fields:

|       |       |             |
|-------|-------|-------------|
| Watt: | 22000 | Pulse/kWh   |
| VAR:  | 5000  | Pulse/kvarh |

Other visible settings include:

- Communication Channel 1: Protocol: Modbus, Address: 1, Baud Rate: 19200 bps, Parity: None 1
- Communication Channel 2: Protocol: Default, Address: 1, Baud Rate: 38400 bps, Parity: None 1
- Wiring: Voltage: 3LN, Current: 3CT
- PT and CT Ratios: PT1: 400.0 V, CT1: 1000 A, PT2: 400.0 V, CT2: 100 mV
- Real-Time Reading: Secondary (selected), Primary (unselected)
- I L1, I L2, I L3 Direction: All set to Positive
- Security: Change Password button
- Demand: Fixed Window Demand, Averaging Interval Window: 15 min, Sub-Interval: 1 min
- Other: Turn On the Backlight: 10 min

Figure 5-35 DO Energy Pulse Constant Configuration from Acuvim software

### Pulse Constant Configuration using Pulse Calculator:

If users are accessing the meter using the Acuvim software, there is a pulse constant calculator tool that can be used to determine the correct pulse constant. Click on the **Tools** menu and select **Calculate Pulse Constant**.

- Under the **PT and CT Ratios** section of the page, enter the PT1 and PT2 which represent the rated input and output of the Potential Transformer (PT) that is being used with the meter. If PTs are not being used, leave these settings as the default of 400 for both PT1 and PT2.
- Enter the CT1 and CT2 values which represent the rated input and output of the Current Transformer (CT) being used with the meter.

**NOTE:** If this is a 333mV current input meter, consider CT2 as 1A. If this is a Rope CT meter, consider CT2 as 1A.

- Enter the value of the **Primary Maximum Power** by performing the following calculation:  **$3 \cdot (PT1 \cdot CT1) / 1000$**
- Next enter in the desired pulse width and minimum interval for the energy pulse. The range for the pulse width is 20-1000ms.
- Once all values are entered, click on **Calculate Pulse Constant**
- The calculator will return the Maximum/Minimum values for the number of pulses as well as how much one pulse will represent with the configured PT/CT ratios and Primary Maximum Power.
- In the '**(Primary) 1 Pulse =**', enter in the amount of energy (kWh) needed to represent 1 pulse.
- Next, click on the **Update** button. The pulse constant will be displayed in the '**(Secondary) 1 kWh(kvarh) =**' section of the window.
- Once the pulse constant is determined, it will need to be configured in the general settings. In Figure 5-35, the pulse constant that is entered into the meter is 100.

Figure 5-36 Pulse Constant Calculator from Accuview software

### 5.1.10 Analog Output

The analog output is supported in the AXM-IO2 module where users can convert measured electrical parameters into an analog voltage (0-5V/1-5V) or current (4-20mA/0-20mA).

#### Viewing the Digital status from the Meters Display:

- Press **H** and **V/A** at the same time. The screen will go blank, and **Meter** will begin flashing.
- Press the **P** or **E** button to move the flashing cursor over to **Digital I/O** and press **V/A** to enter.
- Next users will see the I/O selection screen. Select the appropriate I/O module and press **V/A**.
- With the cursor on **AO** press **V/A** to view the Analog Output readings.

**NOTE:** Refer to Chapter 3 section 3.7.4 on how to configure the AO from the meter's display.

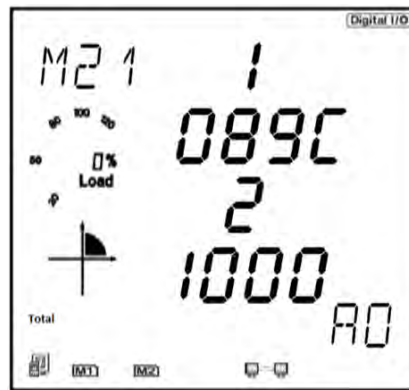

Figure 5-37 Analog Output readings from the meter's display

The values on the meter's display are in hex. The following equations will allow user to convert to the correct mA or voltage value. Using the equations below, the value of 089C for AO1 converts to 10.76mA or 2.69V and the value of 1000 for AO2 converts to 20mA or 5V.

$$\text{Real Value} = \frac{\text{Displayed value}}{4096} \times 20\text{mA}$$

$$\text{Real Value} = \frac{\text{Displayed value}}{4096} \times 5\text{V}$$

Figure 5-38 Analog Output conversion equations

**How to view and configure the Analog Output from the Acuvue software:**

The Analog Output settings can be configured from the Acuvue software on the **I/O Modules \*1** or **I/O Modules \*2** page under the **Settings** tab depending on the logic number of the I/O module being used. There are two AO channels that can be configured under the **Raw Channel** of **AO** section.

- **AO1/AO2:** Can be set to any of the parameters in Table 5-3
- **AO Type:** Can be set to 0-20mA/4-20mA (mA model) or 0-5V/1-5V (V model)

**NOTE:** The Setting value in Table 5-3 refers to the value configured when setting the analog output from the meter's display.

**Table 5-3 Analog Output Parameters**

| Setting Value | Parameter                    |
|---------------|------------------------------|
| 0             | Frequency                    |
| 1             | Phase A Voltage              |
| 2             | Phase B Voltage              |
| 3             | Phase C Voltage              |
| 4             | Average Line-Neutral Voltage |
| 5             | Line Voltage AB              |
| 6             | Line Voltage BC              |
| 7             | Line Voltage CA              |
| 8             | Average Line-Line Voltage    |
| 9             | Phase A Current              |
| 10            | Phase B Current              |
| 11            | Phase C Current              |
| 12            | Average Current              |
| 13            | Neutral Current              |
| 14            | Phase A Power                |
| 15            | Phase B Power                |
| 16            | Phase C Power                |
| 17            | Total System Power           |
| 18            | Phase A Reactive Power       |
| 19            | Phase B Reactive Power       |
| 20            | Phase C Reactive Power       |
| 21            | Total Reactive Power         |
| 22            | Phase A Apparent Power       |
| 23            | Phase B Apparent Power       |
| 24            | Phase C Apparent Power       |
| 25            | Total Apparent Power         |
| 26            | Phase A Power Factor         |
| 27            | Phase B Power Factor         |

| Setting Value | Parameter            |
|---------------|----------------------|
| 28            | Phase C Power Factor |
| 29            | Total Power Factor   |



Figure 5-39 Analog Output settings

In the **AO Input/Output Transfer Curve** section, users can configure the scaling of the Analog Output signal relative to the parameter selected.

- **Single Slope:** When a single slope is selected, only the minimum (X1) and maximum (X4) values need to be specified to represent the AO signal. I.e., if the AO is a 4-20mA signal, the minimum value of the parameter will be 4mA (Y1) and the maximum will be 20mA (Y2).
- **Dual Slope:** When dual slope is selected, the minimum (X1), maximum (X4) and middle point (X2) need to be specified to represent the AO signal. I.e., if the AO is a 4-20mA signal, the minimum value of the parameter will be 4mA (Y1), the middle point of the parameter will be 12mA (Y2) and the maximum will be 20mA (Y2).
- **Triple Slope:** When the triple slope is selected, four points need to be specified for both the input parameter and Analog Output. The four points should be configured in increasing order.

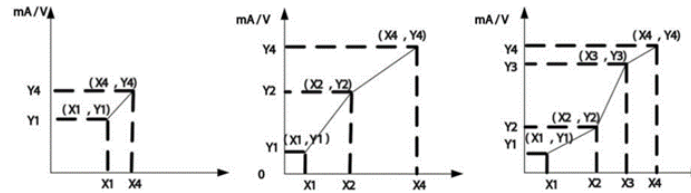

Figure 5-40 Relationship between analog output and electrical parameters

Certain parameters have a range that can be configured for the AO.

- Frequency: 45Hz-65Hz
- Phase Voltage: V1, V2, V3, and Vavg: 0-480V
- Line Voltage: V12, V23, V31, and Vavg: 0-831V
- Current: I1, I2, I3, and Iavg depend on the current input of the meter
  - 5A:  $0-(CT1*10)/CT2$  A
  - 1A:  $0-(CT1*10)/CT2$  A
  - 333mV/RCT/mA:  $0-(CT1/(CT2/10))$  A
- Power Factor: -1.0 to 1.0
- Power:  $-(3*480*I)$  to  $(3*480*I)$ , where "I" is the CT1 value
  - Phase Power:  $480*I$ , where "I" is the CT1 value

**NOTE:** The maximum value of the AO will be 1.2 times the range. For example, 6V for analog voltage and 24mA for analog current.

**NOTE:** When the wiring mode of the meter is in either 2LL or 3LL, the phase measurements for the voltage, active, reactive, apparent power, and power factor will be 0.

**Reading the Analog Output from the Acuvue software:**

To read the value of the Analog Output from the Acuvue software, click on either the **I/O Modules \*1** or **I/O Modules \*2** page under the **Readings** tab depending on the logic number of the I/O module being used.

## Acuvim II Series Power Meter



Figure 5-41 Analog Output readings on the Acuvim software

### 5.1.11 Analog Input

The analog input is supported in the AXM-IO3 module where users can read either 0-20mA/4-20mA or 0-5V/1-5V. Analog input can measure into an analog voltage (0-5V) or current (4-20mA).

#### Viewing the Analog Input reading from the Meters Display:

- Press **H** and **V/A** at the same time. The screen will go blank, and **Meter** will begin flashing.
- Press the **P** or **E** button to move the flashing cursor over to **Digital I/O** and press **V/A** to enter.
- Next users will see the I/O selection screen. Select the appropriate I/O module and press **V/A**.
- With the cursor on **AI** press **V/A** to view the Analog Input readings.

**NOTE:** Refer to Chapter 3 section 3.7.4 on how to configure the AI from the meters display.

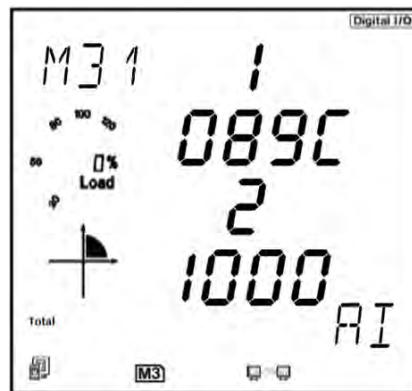

Figure 5-42 Analog Input reading from the meter display

The analog input value can be viewed on the meter's display as a hex number. The AI value ranges from 0-4095.

The figure below shows the relationship between the AI value and the input analog value. Similar to the analog output, the analog input can be converted.

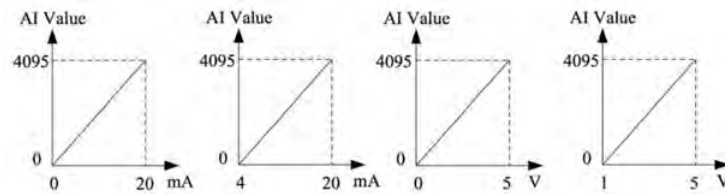

Figure 5-43 relationship between AI value and input analog value

$$Real\ Value = \frac{Displayed\ value}{4096} \times 5V$$

$$Real\ Value = \frac{Displayed\ value}{4096} \times 20mA$$

Figure 5-44 Analog Input conversion equation

**Viewing the Analog Input Reading from the Acuview software:**

The Analog Input settings can be configured from the Acuview software on the *I/O Modules \*1* or *I/O Modules \*2* page under the **Settings** tab depending on the logic number of the I/O module being used. Users can configure the input signal type. If they have a mA version, the input can be configured as 0-20mA/4-20mA, or if the voltage type is used, the input can be configured as 0-5V/1-5V.

## Acuvim II Series Power Meter

The screenshot shows the configuration interface for three modules: AXH-1011, AXH-1021, and AXH-1031. The AXH-1031 module configuration is the focus, with the 'AI Type' dropdown menu highlighted in red. The 'AI Type' is currently set to '4 ~ 20mA'. Other settings for AXH-1031 include DI 1 Type: State, DI 2 Type: State, DI 3 Type: Counter, DI 4 Type: Counter, DI Pulse Const: 1, Pulse = 1, RO Type: Relay Control, and RO Relay Control Output Mode: Momentary with an On Time of 50 ms. An 'Update Device' button is located at the bottom right of the configuration area.

Figure 5-45 Analog Input Type Setting

### Reading the analog input value from the Acuvim software:

Similar to the display, the analog input value is read as a hex number and needs to be converted to the correct mA or V signal. In the figure below, AI1 reads 9 which converts to 0.01V or 0.044mA and AI2 reads 3420 which converts to 4.17V or 16.7mA.

The screenshot displays the 'Readings > [IO Modules \*1]' window. It shows the status of three modules: AXH-1011, AXH-1021, and AXH-1031. For each module, Relay 1 and Relay 2 are shown as OFF with a 'Control' button. DI 1 through DI 6 are shown as 0. For AXH-1021, AO 1 is 10.000 mA and AO 2 is 16.724 mA. For AXH-1031, AI 1 is 9 and AI 2 is 3420.

| Module   | Relay 1 | Relay 2 | DI 1 | DI 2 | DI 3 | DI 4 | DI 5 | DI 6 | AO 1      | AO 2      | AI 1 | AI 2 |
|----------|---------|---------|------|------|------|------|------|------|-----------|-----------|------|------|
| AXH-1011 | OFF     | OFF     | 0    | 0    | 0    | 0    | 0    | 0    |           |           |      |      |
| AXH-1021 |         |         | 0    | 0    | 0    | 0    |      |      | 10.000 mA | 16.724 mA |      |      |
| AXH-1031 | OFF     | OFF     | OFF  | OFF  | 0    | 0    |      |      |           |           | 9    | 3420 |

Figure 5-46 Analog Input Readings on the Acuvim software

## 5.2 Profibus Module AXM-PROFI

### 5.2.1 Introduction of PROFIBUS Technology

Profibus (Process Field Bus) is an international field bus standard that is widely used in the automation technology of manufactures and the flow industry. It is a widely used, open digital communication system which is suitable for high speed, time-critical and high-reliability communications.

PROFIBUS is one kind of open style field bus standard which is promoted by SIEMENS Corporation. In 1989, it became the German standard DIN19245, in 1996, it became the European standard EN50170, in 1999 it was accepted as part of the international standard IEC 61158 and in 2001 it became the Chinese national standard JB/T 10308.3-2001 for field bus of machinery industry controlling systems.

There are 3 types of PROFIBUS: PROFIBUS-DP(Decentralized Periphery), PROFIBUS-PA(Process Automation) and PROFIBUS(Field bus Specification Message). All types follow the same protocol.

With optimized, high-speed, low-cost communication links, PROFIBUS-DP is especially used in automatic controlling systems and equipment level decentralized I/O communication. It can meet real-time response, stability and reliability of equipment level and distributed control systems.

The PROFIBUS module uses the PROFIBUS-DP(V0) protocol.

### 5.2.2 PROFIBUS module application notes

The PROFIBUS technical data and specifications should be read for the AXM-PROFI before using it. In addition, familiarity with the Modbus parameter addresses would be an asset.

The AXM-PROFI can only be used as a slave in the PROFIBUS network. The slave address can range from 0-126 and can only be set through the entrance. If the address is changed, it will take effect immediately.

The AXM-PROFI can operate with baud rates between 9.6kbps to 12Mbps.

The AXM-PROFI terminals should be connected properly to avoid problems during installation.

Please read the GSD file of the PROFIBUS module carefully before using it. The GSD file contains the technical information such as device name, ID number, and other important details.

***Please contact Technical Support (support@accuenergy.com) to obtain the GSD file.***

### 5.2.3 Appearance and Dimensions

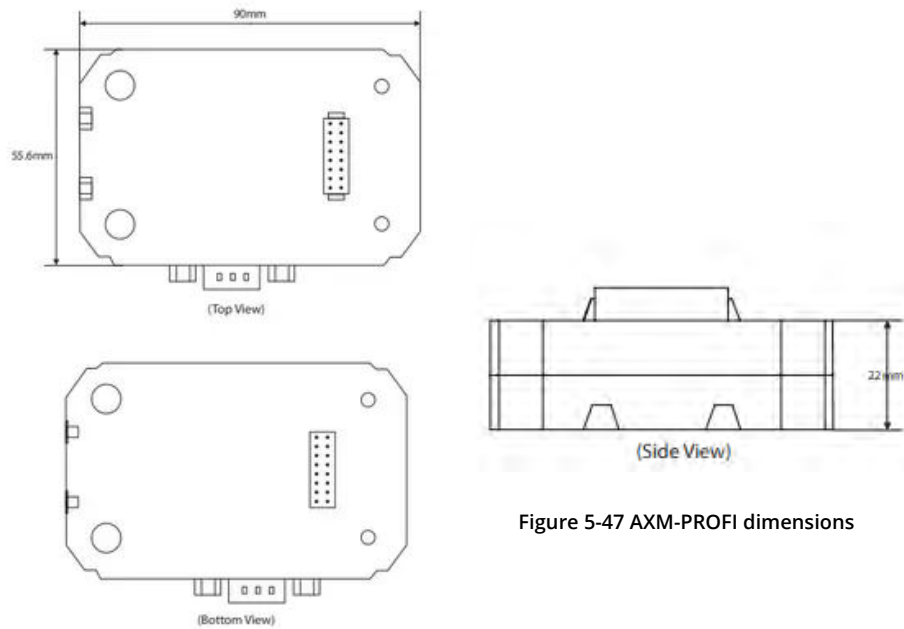

Figure 5-47 AXM-PROFI dimensions

### 5.2.4 Installation Method

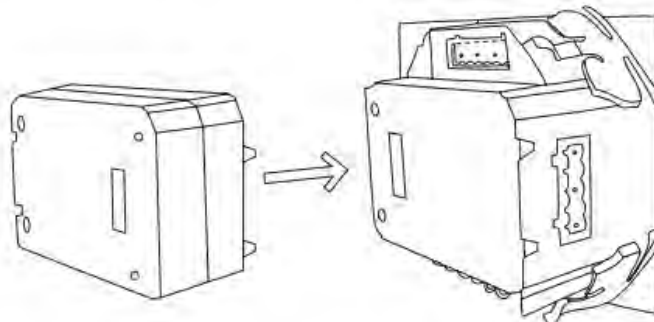

Figure 5-48 AXM-PROFI Installation to Acuvim II meter

The AXM-PROFI module is linked to the Acuvim II series meter by a communication plug. Other extended modules, such as the I/O modules, can be linked to the Acuvim II series meter through the AXM-PROFI.

1. Insert the installation clips to the counterpart of the Acuvim II meter and then press the AXM-PROFI module lightly to establish the linking.
2. Tighten the installation screws.

**NOTE:** Do not install any modules when power is applied to the meter.

### 5.2.5 Definition of DP Interface

The AXM-PROFI module uses a standard 9-pin, D-type connector to access the PROFIBUS network. The mechanical and electrical characteristics of the connector are consistent with the requirements of IEC 807-3. The PROFIBUS connector is a socket, and the counterpart connector of cable is a plug.

The connector pins are as followed:

**Table 5-4 AXM-PROFI Connector Table**

| Pins | RS-485 | ID        | Content               | Used by PROFIBUS |
|------|--------|-----------|-----------------------|------------------|
| 1    | --     | Shield    | Power GND             | NO               |
| 2    | --     | N24V      | -24V output           | NO               |
| 3    | B      | RXD/TXD-P | Data P (Receive/Send) | YES              |
| 4    | --     | CNTR-P    | Controlling P         | YES              |
| 5    | C      | DGND      | Digital Ground        | YES              |
| 6    | --     | Vp        | Positive Voltage      | YES              |
| 7    | --     | P24V      | +24V output           | NO               |
| 8    | A      | RXD/TXD-N | Data N (Receive/Send) | YES              |
| 9    | --     | CNTR-N    | Controlling N         | NO               |

**NOTE:** Pin 4 is used for RTS controlling and TTL, which is optional.

### 5.2.6 Cable

A shielded twisted pair cable is recommended as reference to the EIA RS-485 standard. If the interference is within the EIA RS-485 standard, then a non-shielded twisted pair cable may be used.

### 5.2.7 Bus Terminal

Based on the DP standard, the first station and the last station in the PROFIBUS-DP network should connect the bus terminal (resistor) and it is not necessary for other stations, as shown in the figure below.

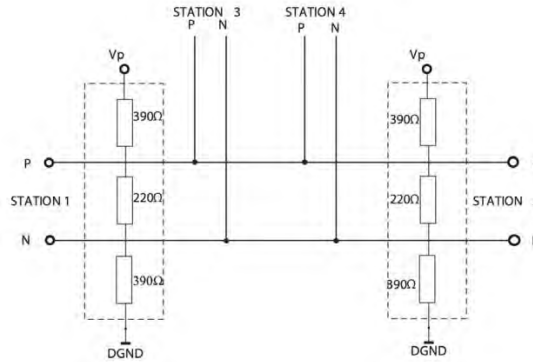

Figure 5-49 DP station Connection Diagram

The bus terminal is composed of three resistors and a connection wire, where Vp is the supply positive voltage and DGND is the Digital Ground. When the bus is idle, the bus terminal makes the data P level higher than data N so the bus's idle signal is always 1.

### 5.2.8 Address Setting

The AXM-PROFI module can only be used as a slave in the PROFIBUS network. Its slave address ranges from 0-126, which can only be configured from the meter display. If the address is changed, it will take effect immediately.

The figure below shows the configuration setting for the AXM-PROFI:



Figure 5-50 AXM-PROFI address setting on meter display

### 5.2.9 Baud Rate

The AXM-PROFI supports baud rates from 9.6kbps to 12Mbps in the PROFIBUS network.

### 5.2.10 GSD Files

A PROFIBUS-DP Master can exchange data with various slave devices. In order to identify a slave device, it is not necessary to obtain the technical data of the device itself. The file where the data is described is called the Device Description Data File (GSD).

Because of the importance of the GSD file, please read it carefully before using the AXM-PROFI module. The GSD file is provided in pure text format with detailed comments.

- As a DP slave device, the AXM-PROFI module supports the protocol of V0 revision.
- The AXM-PROFI module data interface is optional. It supports module 1 and module 2. Module 1 is a 16-bit word input/output interface. Module 2 is a 32-bit input with 1 output interface.

### 5.2.11 Information Exchange

A variety of information from the Acuvim II meter can be transmitted by the AXM-PROFI module, such as electrical measurements and other parameters. The basic communication method of the Acuvim II series meter is RS-485, which uses the Modbus-RTU protocol. In order to use the same addresses as Modbus, the communication format of PROFIBUS-DP is 16-bit word input/output.

It is recommended to refer to the communication part of the Acuvim II manual (Chapter 6) for the list of Modbus addresses, function codes, the relationship between values, and other details.

Some examples are:

1. There are various function codes, such as 01H, 02H, 04H, 05H, and 10H for the various categorized parameters. Different function codes have different formats for the query and response frames.
2. There are specific relationships between numerical values in the registers and the real physical value.
3. Different parameters may have different data length and data type.

These three points are also suitable for the PROFIBUS-DP protocol in the AXM-PROFI modules.

Function codes, such as 01H, 02H, and 03H, are inquiry commands. For users to quickly switch the inquiry contents, 8 channels are defined, from 1 to 8, in order to update the data more quickly.

### 5.2.12 Format of Function code 01H

Function code 01H is used to the read relay status. The format of this function code is defined as follows:

**Query:**

Table 5-5 Function Code 01H Query Format

|   | Frame Bytes | Caption                     |
|---|-------------|-----------------------------|
| 1 | Byte 1      | Channels 1 to 8             |
| 2 | Byte 2      | 01H                         |
| 3 | Byte 3      | Starting Address high byte  |
| 4 | Byte 4      | Starting Address low byte   |
| 5 | Byte 5      | Quantity of coils high byte |
| 6 | Byte 6      | Quantity of coils low byte  |
| 7 | Byte 7-32   | 0                           |

Here, 16-bit words are usually required for I/O data in GSD file so that all other bytes after Byte 7 are set to 0.

**Response:**

Below is the response of the slave device sending its information to the master device.

Table 5-6 Function 10 Response Format

|   | Frame Bytes | Caption                      |
|---|-------------|------------------------------|
| 1 | Byte 1      | The channel of inquiry frame |
| 2 | Byte 2      | 01H                          |
| 3 | Byte 3      | byte count                   |
| 4 | Byte 4      | coil status                  |
| 5 | Byte 5~32   | 0                            |

The coils in the response message are packed as one coil per bit of the data field. Status is indicated as 1=ON and 0=OFF. The LSB of the first data byte contains the output addressed in the query. The other coils follow toward the high order end of this byte, and from low order to high order in subsequent bytes.

Example: reading Relay1 and Relay2 status (start register address is 0000H). Use 4 channels.

**Query:**

| Byte1 | Byte2 | Byte3 | Byte4 | Byte5 | Byte6 | Byte7-32 |
|-------|-------|-------|-------|-------|-------|----------|
| 04H   | 01H   | 00H   | 00H   | 00H   | 02H   | 00H      |

**Response:**

| Byte1 | Byte2 | Byte3 | Byte4 | Byte5 | Byte6 | Byte7-32 |
|-------|-------|-------|-------|-------|-------|----------|
| 04H   | 01H   | 01H   | 02H   | 00H   | 00H   | 00H      |

**Coil Status:**

| 7 | 6 | 5 | 4 | 3 | 2 | 1 | 0 |
|---|---|---|---|---|---|---|---|
| 0 | 0 | 0 | 0 | 0 | 0 | 1 | 0 |

MSB LSB

(Relay 1 = OFF, Relay 2=ON)

**5.2.13 Format of function code 05H**

The message with function code (05H) in MODBUS-RTU forces a single relay to either the on or off position. The data value FFOOH will set the relay on and the value 0000H will turn it off. All other values are invalid and will not affect the relay. In PROFIBUS-DP, the format of function code 05H is defined as follows:

**Query:**

Table 5-7 Function Code 05H Query Format

|   | Frame Bytes | Caption                   |
|---|-------------|---------------------------|
| 1 | Byte 1      | FAH                       |
| 2 | Byte 2      | 05H                       |
| 3 | Byte 3      | outputs address high byte |
| 4 | Byte 4      | outputs address low byte  |
| 5 | Byte 5      | outputs value high byte   |
| 6 | Byte 6      | outputs value low byte    |
| 7 | Byte 7-32   | 0                         |

**NOTE:** Because PROFIBUS-DP V0 exchanges information periodically, controlling information such as function code 05H should be used carefully.

**Response:**

The normal response to the command request is to re-transmit the message as received after the relay status has been altered.

Table 5-8 Function Code 05H Response Format

|   | Frame Bytes | Caption                   |
|---|-------------|---------------------------|
| 1 | Byte 1      | FAH                       |
| 2 | Byte 2      | 05H                       |
| 3 | Byte 3      | outputs address high byte |
| 4 | Byte 4      | outputs address low byte  |
| 5 | Byte 5      | outputs value high byte   |
| 6 | Byte 6      | outputs value low byte    |
| 7 | Byte 7~32   | 0                         |

Example: setting Relay2 on.

**Query:**

| Byte1 | Byte2 | Byte3 | Byte4 | Byte5 | Byte6 | Byte7~32 |
|-------|-------|-------|-------|-------|-------|----------|
| FAH   | 05H   | 00H   | 01H   | FFH   | 00H   | 00H      |

**Response:**

| Byte1 | Byte2 | Byte3 | Byte4 | Byte5 | Byte6 | Byte7~32 |
|-------|-------|-------|-------|-------|-------|----------|
| FAH   | 05H   | 00H   | 01H   | FFH   | 00H   | 00H      |

**5.2.14 Format of function code 02H**

Function code 02H is used to read DI status in MODBUS-RTU. In PROFIBUS-DP, the format of function code 02H is defined as follows:

**Query:**

Table 5-9 Function Code 02H Query Format

|   | Frame Bytes | Caption                              |
|---|-------------|--------------------------------------|
| 1 | Byte 1      | Channels can be chosen from 1 to 8   |
| 2 | Byte 2      | 02H                                  |
| 3 | Byte 3      | starting address high byte           |
| 4 | Byte 4      | starting address low byte            |
| 5 | Byte 5      | quantity of digital inputs high byte |
| 6 | Byte 6      | quantity of digital inputs low byte  |
| 7 | Byte 7~32   | 0                                    |

**Response:**

Table 5-10 Function Code 02H Response Format

|   | Frame Bytes | Caption                      |
|---|-------------|------------------------------|
| 1 | Byte 1      | The channel of inquiry frame |
| 2 | Byte 2      | 02H                          |
| 3 | Byte 3      | byte count                   |

|   | Frame Bytes | Caption               |
|---|-------------|-----------------------|
| 4 | Byte 4      | inputs status1        |
| 5 | Byte 5      | inputs status2 (or 0) |
| 6 | Byte 6      | inputs status3 (or 0) |
| 7 | Byte 7      | inputs status4 (or 0) |
| 8 | Byte 8-32   | 0                     |

The digital inputs in the response message are packed as one input per bit of the data field. Status is indicated as 1=ON; 0=OFF. The LSB of the first data byte contains the input addressed in the query. The other inputs follow towards the high order end of this byte, and from low order to high order in subsequent bytes.

Example: reading 4 DI statuses (starting address is 0000H). Use 6 channels.

**Query:**

| Byte1 | Byte2 | Byte3 | Byte4 | Byte5 | Byte6 | Byte7-32 |
|-------|-------|-------|-------|-------|-------|----------|
| 06H   | 02H   | 00H   | 00H   | 00H   | 04H   | 00H      |

**Response:**

| Byte1 | Byte2 | Byte3 | Byte4 | Byte5-32 |
|-------|-------|-------|-------|----------|
| 06H   | 02H   | 01H   | 06H   | 00H      |

**DI Status:**

| 7 | 6 | 5 | 4 | 3 | 2 | 1 | 0 |
|---|---|---|---|---|---|---|---|
| 0 | 0 | 0 | 0 | 0 | 1 | 1 | 0 |

MSB

LSB

(DI1 = OFF, DI2=ON, DI3 = ON, DI4 = OFF)

**5.2.15 Format of function code 03H**

This function code is used in MODBUS-RTU to read the contents of a contiguous block of holding registers in Acuvim II meter. In PROFIBUS-DP, the format of function code 03H is defined as follows:

**Query:**

Table 5-11 Function Code 03H Query Format

|   | Frame Bytes | Caption                            |
|---|-------------|------------------------------------|
| 1 | Byte 1      | Channels can be chosen from 1 to 8 |
| 2 | Byte 2      | 03H                                |
| 3 | Byte 3      | starting address high byte         |

## Acuvim II Series Power Meter

|   | Frame Bytes | Caption                         |
|---|-------------|---------------------------------|
| 4 | Byte 4      | starting address low byte       |
| 5 | Byte 5      | quantity of registers high byte |
| 6 | Byte 6      | quantity of registers low byte  |
| 7 | Byte 7~32   | 0                               |

“Quantity of registers” identifies how many words will be read.

### Response:

Table 5-12 Function Code 03H Response Format

|   | Frame Bytes | Caption                      |
|---|-------------|------------------------------|
| 1 | Byte 1      | The channel of inquiry frame |
| 2 | Byte 2      | 03H                          |
| 3 | Byte 3      | byte count                   |
| 4 | Byte 4      | Register value1 high byte    |
| 5 | Byte 5      | Register value1 low byte     |
| 6 | Byte 6      | .....                        |
| 7 | Byte 7~32   | .....                        |

“Byte count” identifies how many bytes will be read.

The register data in the response message is packed as two bytes per register, with the binary contents correctly justified with each byte. For each register, the first byte contains the high order bits and the second contains the low order bits.

**NOTE:** The response has a 16-word frame, so the maximum “quantity of registers” should less than 15. Otherwise, it will return an error result.

Example: Reading 3 measured data (F, V1, V2) from Acuvim II meter.

The data address of F includes 4000H and 4001H. The data address of V1 includes 4002H and 4003H. The data address of V2 includes 4004H and 4005H. (Uses 7 channels)

### Query:

| Byte1 | Byte2 | Byte3 | Byte4 | Byte5 | Byte6 | Byte7~32 |
|-------|-------|-------|-------|-------|-------|----------|
| 07H   | 03H   | 40H   | 00H   | 00H   | 06H   | 00H      |

### Response:

| Byte1 | Byte2  | Byte3  | Byte4  | Byte5  | Byte6  | Byte7  | Byte8     |
|-------|--------|--------|--------|--------|--------|--------|-----------|
| 07H   | 03H    | 0CH    | 42H    | 48H    | 00H    | 00H    | 42H       |
| Byte9 | Byte10 | Byte11 | Byte12 | Byte13 | Byte14 | Byte15 | Byte16~32 |
| C7H   | CCH    | CDH    | 42H    | C8H    | 33H    | 33H    | 00H       |

(F=42480000H(50.00Hz), V1=42C7CCCDH(99.9v), V2=42C83333H(100.1v)).

**NOTE:** The relationship between the numerical value in the register of the meter and the actual physical value is described in Chapter 6.

### 5.2.16 Format of function code 10H

This function code is used in MODBUS-RTU to write a block of continuous registers in the Acuvim II meter, such as system parameters setting and so on. In PROFIBUS-DP, the format of function code 10H is defined as follows:

**Query:**

Table 5-13 Function Code 10H Query Format

|    | Frame Bytes | Caption                         |
|----|-------------|---------------------------------|
| 1  | Byte 1      | FAH                             |
| 2  | Byte 2      | 10H                             |
| 3  | Byte 3      | starting address high byte      |
| 4  | Byte 4      | starting address low byte       |
| 5  | Byte 5      | quantity of registers high byte |
| 6  | Byte 6      | quantity of registers low byte  |
| 7  | Byte 7      | byte count                      |
| 8  | Byte 8      | register value 1 high byte      |
| 9  | Byte 9      | register value 1 low byte       |
| 10 | Byte 10     | register value 2 high byte      |
| 11 | Byte 11     | register value 2 high byte      |
| 12 | .....       | .....                           |
| 13 | Byte 32     | 0                               |

“Quantity of registers” indicates how many words will be written.

“Byte count” indicates how many bytes will be written. If the “quantity of register” is N, then “byte count” is (N×2).

**NOTE:** The response has a 16-word frame, so the maximum “quantity of registers” should be less than 13. Otherwise, it will return an error result.

**Response:**

The normal Response returns the function code, starting address, and quantity of registers written.

**Table 5-14 Function Code 10H Response Format**

|   | Frame Bytes | Caption                         |
|---|-------------|---------------------------------|
| 1 | Byte 1      | FAH                             |
| 2 | Byte 2      | 10H                             |
| 3 | Byte 3      | starting address high byte      |
| 4 | Byte 4      | starting address low byte       |
| 5 | Byte 5      | quantity of registers high byte |
| 6 | Byte 6      | quantity of registers low byte  |
| 7 | Byte 7~32   | 0                               |

**Example:** Preset the import active energy (EP\_imp) to 17807783.3 KWh. Based on the relationship between the register value and the physical value, we can get the register value in hex as 0A9D4089H. The data address of EP\_imp includes 4048H and 4049H.

**Query:**

| Byte1 | Byte2 | Byte3 | Byte4 | Byte5 | Byte6 | Byte7 | Byte8 | Byte9 | Byte10 | Byte11 | Byte12~32 |
|-------|-------|-------|-------|-------|-------|-------|-------|-------|--------|--------|-----------|
| FAH   | 10H   | 40H   | 48H   | 00H   | 02H   | 04H   | 0AH   | 9DH   | 40H    | 89H    | 00H       |

**Response:**

| Byte1 | Byte2 | Byte3 | Byte4 | Byte5 | Byte6 | Byte7~32 |
|-------|-------|-------|-------|-------|-------|----------|
| FAH   | 10H   | 40H   | 48H   | 00H   | 02H   | 00H      |

**Example Projects**

To facilitate your understanding of the PROFIBUS module, we have developed a PLC-based DEMO engineering application program. Please read the DEMO procedure documentation for specific information. This DEMO is available upon request; please call Technical Support.

**5.2.17 32 Word Output Interface**

The 32-word output interface is a fixed parameter.

Transmission format is as follows:

- Ua\_rms(2 bytes), Ub\_rms(2 bytes), Uc\_rms(2 bytes), Uavg\_rms(2 bytes);
- Uab\_rms(2 bytes), Ubc\_rms(2 bytes), Uca\_rms(2 bytes), Ulag\_rms(2 bytes);
- Ia\_rms(2 bytes), Ib\_rms(2 bytes), Ic\_rms(2 bytes), Iavg\_rms(2 bytes);
- Pa\_rms(2 bytes), Pb\_rms(2 bytes), Pc\_rms(2 bytes), Pavg\_rms(2 bytes);

Epa\_imp(4 bytes), Epa\_exp(4 bytes);

Epb\_imp(4 bytes), Epb\_exp(4 bytes);

Epc\_imp(4 bytes), Epc\_exp(4 bytes);

Ep\_imp(4 bytes), Ep\_exp(4 bytes);

## 5.3 RS485 Module (AXM-485)

### 5.3.1 Communication Parameters Setting

RS485, also known as EIA-485, is a telecommunications standard for binary serial communications between devices. RS485 is the most versatile communication standard in the standard series defined by the EIA, and it is a widely used communication interface in Data Acquisition and Control applications where multiple nodes communicate with each other.

The RS485 signals are floating, and each signal is transmitted over a differential signal + line and a differential signal - line. The RS485 receiver compares the voltage difference between both lines, instead of the absolute voltage level on a signal line. To obtain better communication performance, the differential signal + and differential signal - lines are twisted. The twisted-pair adds immunity against noise. If high noise immunity is needed, the combination of twisting and shielding is often used. For example, shielded twisted pair or foiled twisted pair networking cables can be used in high noise environments.

### 5.3.2 Function Description of RS485 module

AXM-RS485 module uses RS485 serial communication and the Modbus-RTU protocol, just like the on-board RS485 port of the Acuvim II series meter. It provides a second RS485 port for serial communication and it can work with the on-board RS485 serial communication simultaneously. The terminals of communication are generally A, B, and S where A is for the differential signal +, B is for the differential signal -, and S is connected to the shield of the twisted pair cables.

- Up to 32 devices can be connected on an RS485 bus without repeaters.
- Use good quality shielded twisted pair cable, AWG22 (0.5mm<sup>2</sup>) or higher.
- The overall length of the RS485 cable connecting all devices should not exceed 1200m (4000ft).
- Every A(+) should be connected to A(+), B(-) to B(-), otherwise, it will influence the network or damage the communication interface.
- When using a long communication cable to connect several devices, and anti-signal reflecting resistor (typical value 120Ω-300Ω/0.25W) is normally added to the end of the cable beside the last meter to prevent communication quality degradation.

### 5.3.3 Appearance and Dimensions

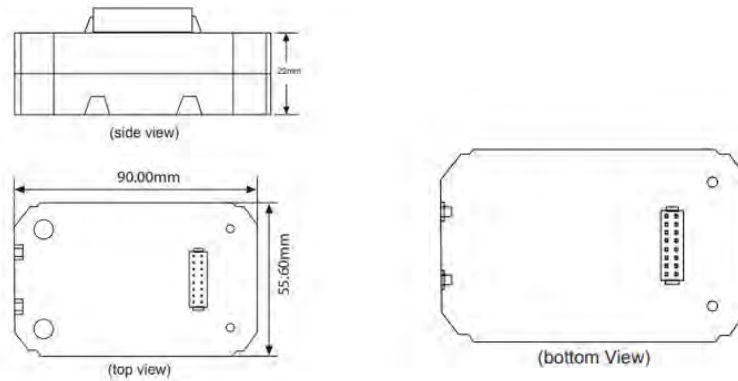

Figure 5-51 AXM-RS485 Dimensions

### 5.3.4 Installation Method

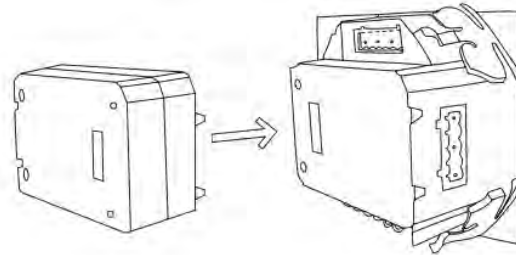

Figure 5-52 AXM-RS485 installation to Acuvim II meter

The RS485 module is linked to the meter by a communication plug. It also can be linked to other extended modules.

1. Insert the installation clips to the counterpart of the meter, and then press the RS485 module lightly, so linking is established.
2. Tighten the installation screws.

**NOTE:** Install AXM-RS485 Module carefully to avoid damage. Under no circumstances should any installation be done with the meter powered on. Failure to do so may result in injury or death.

### 5.3.5 Connection Method

The RS485 module uses 2-wire, half-duplex communication mode, which is the same as what the on-board RS485 port is using. If the master does not have an RS485 communication port, a converter (such as an RS232/RS485 or a USB/RS485 converter) will be required. Typical RS485 Network topologies include line, circle, and star. The shield of each segment of the RS485 cable must be connected to the ground at one end only.

The default baud rate of the RS485 module is 38400 bps. Users can change the baud rate in system settings S03 of the Acuvim II series meter.



Figure 5-53 Baud Rate setting for the AXM-RS485 module

The data format is start bit + 8n data bit + parity + stop bit. NON1, NON2, odd, and even can be selected for parity mode on S31 of Setting page of Acuvim II meter.

- **NON1:** represents non-parity, single stop bit
- **NON2:** represents non-parity, double stop bit
- **Odd:** represents odd-parity, single stop-bit
- **Even:** represents even parity, single stop bit.

The default setting for the parity is NON1.



Figure 5-54 Parity setting for the AXM-RS485 module

**NOTE:** If AXM-WEB/AXM-WEB2 is used, the RS-485 module's parity (PAR2) must be set as None1 so that the meter will recognize the communications module.

### 5.3.6 Communication Address

The communication address used for the AXM-RS485 module is located on page S36.

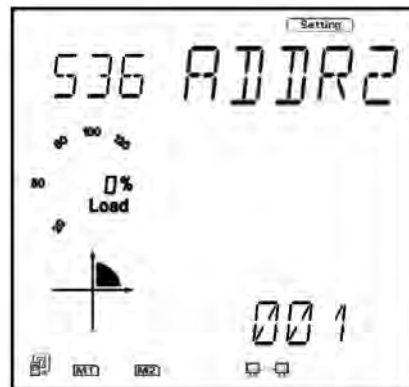

Figure 5-55 Address setting for AXM-RS485

## Chapter 6: Communication Part I

This chapter will mainly discuss how to communicate using the Modbus protocol. It is highly recommended that previous chapters be read before moving onto Chapter 6, a familiarity with Modbus would also be helpful.

### 6.1 Modbus Protocol Introduction

Modbus RTU is the communication protocol used in Acuvim II series meters. Data format and error check methods are defined in the Modbus protocol. The half duplex query and respond mode is adopted in the Modbus protocol. There is only one master device in the communication network. The others are slave devices, waiting for the query of the master.

#### Transmission Mode

The mode of transmission defines the data structure within a frame and the rules used to transmit data. The mode is defined in the following which is compatible with Modbus RTU mode.

#### Framing

Table 6-1 Data Framing

| Address              | Function | Data                               | Check   |
|----------------------|----------|------------------------------------|---------|
| 8-Bits               | 8-Bits   | Nx8-Bits                           | 16-Bits |
| <b>Coding System</b> |          | <b>8-Bit Binary</b>                |         |
| Start Bit            |          | 1                                  |         |
| Data Bits            |          | 8                                  |         |
| Parity               |          | No parity, odd parity, even parity |         |
| Stop Bit             |          | 1 or 2                             |         |
| Error Checking       |          | CC check                           |         |

#### Address Field

The address field of a message frame contains eight bits. Valid slave device addresses are in the range of 0~247 decimal. A master addresses a slave by placing the slave address in the address field of the message. When the slave sends its response, it places its own address in this address field of the response to let the master know which slave is responding.

### Function Field

The function code field of a message frame contains eight bits. Valid codes are in the range of 1~255 decimal. When a message is sent from a master to a slave device the function code field tells the slave what kind of action to perform.

Table 6-2 Function Code Transmission

| Code | Meaning                        | Action   |
|------|--------------------------------|--|
| 01   | Read Relay Output Status       | Obtain current status of Relay Output  |
| 02   | Read Digital Input (DI) Status | Obtain current status of Digital Input                                       |
| 03   | Read Data                      | Obtain current binary value from one or more registers                       |
| 05   | Control Relay Output           | Force relay state to "ON" or "OFF"   |
| 16   | Press Multiple-Register        | Place specific binary values into a series of consecutive Multiple-Registers |

### Data Field

The data field is constructed using sets of two hexadecimal digits, in the range of 00 to FF hexadecimal. The data field of messages sent from a master to slave devices contains additional information which the slave must use to take the action defined by the function code. This can include items such as register addresses, the quantity of items to be handled, and the count of actual data bytes in the field. For example, if the master writes to a group of registers in the slave (function code 10 hexadecimal), the data field specifies the starting register, how many registers to write, the count of data bytes to follow 234 in the data field, and the data to be written into the registers.

If no error occurs, the data field of a response from a slave to a master contains the data requested. If an error occurs, the field contains an exception code that the master application can use to determine the next action to be taken. The data field can be non-existent if there is zero length in certain kinds of messages.

### Error Check Field

Every message includes an error checking field which is based on the Cyclical Redundancy Check (CRC) method. The CRC field checks the contents of the entire message. It is applied regardless of any parity check method used for the individual characters of the message. The CRC field is two bytes long, containing a 16-bit binary value. The CRC value is calculated by the transmitting device, and is appended to the message. The receiving device recalculates the CRC value during reception of the message, and compares the calculated value to the actual value it received in the CRC field. If the two values are not equal, an error will be reported. CRC calculation is first started by

preloading the whole 16-bit register to 1's. The process begins by applying successive 8-bit bytes of the message to the current contents of the register. Only the eight bits of data in each character are used for generating the CRC. Start and stop bits and the parity bit do not apply to the CRC. When generating the CRC, each 8-bit character is exclusive "ORed" with the register contents. The result is shifted towards the least significant bit (LSB), with a zero filled into the most significant bit (MSB) position. The LSB is extracted and examined, if the LSB equals to 1, the register is exclusive "ORed" with a preset, fixed value; if the LSB equals to 0, no action will be taken. This process is repeated until eight shifts have been performed. After the last (eighth) shift, the next 8-bit byte is exclusive ORed with the register's current value, and the process repeats for eight more shifts as described above. After all the bytes of the message have been applied, the final contents of the register, which should exchange the high-byte and the low-byte, is the CRC value. When the CRC is appended to the message, the low-order byte is appended first, followed by the high-order byte.

## 6.2 Communication Format

Table 6-3 Explanation of Frame

| Address | Function | Data start register HI | Data start register LO | Number of data start registers HI | Number of data start registers LO | CRC 16 HI | CRC 16 LO |
|---------|----------|------------------------|------------------------|-----------------------------------|-----------------------------------|-----------|-----------|
| 06H     | 03H      | 00H                    | 00H                    | 00H                               | 21H                               | 84H       | 65H       |

### 1. Reading Relay Status

Function Code 01

This function code is used to read the status of the relay in the meter.

1=On, 0=Off, Relay1's address is 0000H,

Relay2's address is 0001H and so on.

The following query is to read the relay status for the meter with communication address 17.

**Query:**

Table 6-4 Read the Status of Relay1 and Relay2 Query Message

| Address | Function | Data start register HI | Data start register LO | Number of data start registers HI | Number of data start registers LO | CRC 16 HI | CRC 16 LO |
|---------|----------|------------------------|------------------------|-----------------------------------|-----------------------------------|-----------|-----------|
| 11H     | 01H      | 00H                    | 00H                    | 00H                               | 02H                               | BFH       | SBH       |

**Response:**

The Acuvim II series meter response includes the meter address, function code, quantity of data

## Acuvim II Series Power Meter

byte, the data, and error checking. An example response to read the status of Relay1 and Relay2 is shown as Table 6-5. The status of Relay1 and Relay2 are responding to the last 2 bits of the data.

Relay1: bit0, Relay2: bit1

**Table 6-5 Relay Status Response**

| Address | Function | Byte Count | Data | CRC 16 HI | CRC 16 LO |
|---------|----------|------------|------|-----------|-----------|
| 11H     | 01H      | 01H        | 02H  | D4H       | 89H       |

The content of the data is:

| 7 | 6 | 5 | 4 | 3 | 2 | 1 | 0 |
|---|---|---|---|---|---|---|---|
| 0 | 0 | 0 | 0 | 0 | 0 | 1 | 0 |

MSB LSB

Relay1 = OFF (LSB), Relay2 = ON (Left to LSB)

## 2. Read Status of DI

Function Code 02 1=ON, 0=OFF

DI's address is 0000H, DI2's address is 0001H, and so on.

The following query is to read the status of 4 DI's of Acuvim II series meter with communication address 17.

**Query:**

**Table 6-6 Read the Status of Relay1 and Relay2 Query Message**

| Address | Function | Data start register HI | Data start register LO | Number of data start registers HI | Number of data start registers LO | CRC 16 HI | CRC 16 LO |
|---------|----------|------------------------|------------------------|-----------------------------------|-----------------------------------|-----------|-----------|
| 11H     | 02H      | 00H                    | 00H                    | 00H                               | 04H                               | 7BH       | 59H       |

**Response:**

The Acuvim II series meter response includes the meter address, function code, quantity of data characters, the actual data characters and error checking. An example response to read the status of 4 DI's are shown in Table 6-7. The DI status corresponds to the last 4 bits of the data.

DI1: bit0; DI2: bit1; DI3: bit2; DI4: bit3

**Table 6-7 Relay Status Response**

| DI1: bit0                 |                           | DI2: bit1              |                        | DI3: bit2 |           | DI4: bit3       |
|---------------------------|---------------------------|------------------------|------------------------|-----------|-----------|-----------------|
| Transaction Identifier HI | Transaction Identifier LO | Protocol Identifier Hi | Protocol Identifier LO | Length HI | Length LO | Unit Identifier |
| 11H                       | 02H                       | 00H                    | 00H                    | 00H       | 04H       | 7BH             |

| Function | Byte Count | Data |
|----------|------------|------|
| 02H      | 01H        | 0FH  |

The content of the data is:

| 7 | 6 | 5 | 4 | 3 | 2 | 1 | 0 |
|---|---|---|---|---|---|---|---|
| 0 | 0 | 0 | 0 | 1 | 1 | 1 | 1 |

MSB LSB

### 3. Read Data (Function Code 03)

#### Query:

This function allows the master to obtain the measurement results from the Acuvim II series meter. Table 6-8 is an example of reading the measured data (F, V1 and V2) from slave device number 17, the data address of F is 4000H, 4001H; V1's address is 4002H, 4003 and V2's address is 4004H, 4005H.

Table 6-8 Read F, V1, V2 Query Message

| Address | Function | Data start register HI | Data start register LO | Number of data start registers HI | Number of data start registers LO | CRC 16 HI | CRC 16 LO |
|---------|----------|------------------------|------------------------|-----------------------------------|-----------------------------------|-----------|-----------|
| 11H     | 03H      | 40H                    | 00H                    | 00H                               | 06H                               | D2H       | 98H       |

#### Response:

The Acuvim II series meter response includes the meter address, function code, quantity of data bytes, data and error checking. An example response to read F, V1 and V2 (F=42480000H (50.00Hz), V1=42C7CCCDH (99.9V), V2=42C83333H (100.1V)) is shown:

Table 6-9 Read F, V1 and V2 Message

| Address | Function | Byte Count | Data1 HI | Data1 LO | Data2 HI | Data2 LO | Data3 HI | Data3 LO | Data4 HI | Data4 LO |
|---------|----------|------------|----------|----------|----------|----------|----------|----------|----------|----------|
| 11H     | 3H       | 0CH        | 42H      | 48H      | 00H      | 00H      | 42H      | C7H      | CCH      | CDH      |

| Data5 HI | Data5 LO | Data6 HI | Data6 LO | Data16 HI | Data16 LO |
|----------|----------|----------|----------|-----------|-----------|
| 42H      | C8H      | 33H      | 33H      | CAH       | 7FH       |

### 4. Control Relay (Function Code 05)

#### Query:

This message forces a relay to either turn "ON" or "OFF". Any relay that exists within Acuvim II

## Acuvim II Series Power Meter

Series meter can be forced to either “ON” or “OFF” status. The data value FF00H will set the relay on and the value 0000H will turn it off; all other values are invalid and will not affect that relay.

The example below is a request to the Acuvim II Series meter with the address of 17 to turn on Relay1.

**Table 6-10 Control Relay Query Message**

| Address | Function | DO Address HI | DO Address LO | Value HI | Value LO | CRC 16 HI | CRC 16 LO |
|---------|----------|---------------|---------------|----------|----------|-----------|-----------|
| 11H     | 05H      | 00H           | 00H           | FFH      | 00H      | 8EH       | AAH       |

**Response:**

The normal response to the command request is to re-transmit the message as received after the relay status has been altered.

**Table 6-11 Control Relay Response Message**

| Address | Function | Relay Address HI | Relay Address LO | Value HI | Value LO | CRC 16 HI | CRC 16 LO |
|---------|----------|------------------|------------------|----------|----------|-----------|-----------|
| 11H     | 05H      | 00H              | 00H              | FFH      | 00H      | 8EH       | AAH       |

### 5. Preset/Reset Multi-Register (Function Code 16)

**Query:**

Function 16 allows the user to modify the contents of a multi-register. Some registers of Acuvim II series meter can have their contents changed by this message. The example below is a request to an Acuvim II series meter with the address of 17 to preset Ep\_imp as “17807783.3kWh”, while its HEX value is 0A9D4089H. Ep\_imp data address is 4048H and 4049H.

**Table 6-12 Preset Multi-Registers Query Message**

| Address | Function | Data start register HI | Data start register LO | Number of data start registers HI | Number of data start registers LO | Byte Count |
|---------|----------|------------------------|------------------------|-----------------------------------|-----------------------------------|------------|
| 11H     | 10H      | 40H                    | 48H                    | 00H                               | 02H                               | 04H        |

| Value | Value LO | Value LO | Value LO | CRC HI | CRC LO |
|-------|----------|----------|----------|--------|--------|
| 0AH   | 9DH      | 40H      | 89H      | F1H    | 6AH    |

**Response:**

The normal response to a preset multi-register request includes the Acuvim II Series meter address, function code, data start register, the number of registers, and error checking.

Table 6-13 Preset Multi-Register Response Message

| Address | Function | Data start register HI | Data start register LO | Number of data start registers HI | Number of data start registers LO | CRC 16 HI | CRC 16 LO |
|---------|----------|------------------------|------------------------|-----------------------------------|-----------------------------------|-----------|-----------|
| 11H     | 10H      | 40H                    | 48H                    | 00H                               | 02H                               | D6H       | 8EH       |

### 6.3 Data Address Table and Application Details

There are several rules to follow in using the meter:

#### 6.3.1 Data Type

- “word” refers to 16-bit unsigned integer using one data address and 2 bytes of memory, it varies from 0 to 65535.
- “int” refers to 16-bit integer using one data address and 2 bytes of memory, it varies from -32768 to 32767.
- “dword” refers to 32-bit unsigned integer using two data addresses and 4 bytes of memory with high word at the front and low word at the end, it varies from 0 to 4294967295. Rx=high word\*65536+low word.
- “float” refers to 32-bit single value using two data addresses and 4 bytes of memory, it varies from -1.175494E-38 to 3.402823E+38.

#### 6.3.2 Relationship between communication value and numerical value.

It is important to note that the numerical value may not be the same as the communication value. The following table shows how they respond to each other.

- When current output CTs are selected, the value of CT2 is 1A or 5A, and when using the relationship listed below to count primary value, the value of CT2 should be original 1 or 5.
- When a CT has a voltage output, the value of CT2 is 333mV, and when using the relationship listed below to count primary value, the value of CT2 should not be 333, but 1.
- When using Rogowski Coil CTs (output 100mV/50Hz or 120mV/60Hz), the value of CT2 is 100. When using the relationship listed below to count the primary value, the value of CT2 should not be 100, but 1.
- When you select a 80/100/200 mA CT, the value of CT2 is 80, 100 or 200, and use the relationship listed below to count primary value, the value of CT2 should not be 80, 100 or 200, but 1.

Table 6-14 Relationship of Parameters

| Parameters                  | Relationship                                  | Unit         | Format Code |
|-----------------------------|---|--------------|-------------|
| System parameters           | Numerical value equals to communication value | No unit      | F1          |
| Run-time                    | $T=R_x/100$                                   | Hour         | F2          |
| Clock                       | Numerical value equals to communication value | Unit of time | F3          |
| Energy (primary)            | $E_p=R_x/10$                                  | kWh          | F4          |
| Reactive energy (primary)   | $E_p=R_x/10$                                  | kvarh        | F5          |
| Apparent energy (primary)   | $E_p=R_x/10$                                  | kVA          | F6          |
| Energy (secondary)          | $E_p=R_x/1000$                                | kWh          | F7          |
| Reactive energy (secondary) | $E_p=R_x/1000$                                | kvarh        | F8          |
| Apparent energy (secondary) | $E_p=R_x/1000$                                | kVA          | F9          |
| Frequency                   | $E_p=R_x/100$                                 | Hz           | F10         |
| Voltage                     | $U=R_x \times (PT1/PT2)/10$                   | V            | F11         |
| Current, current demand     | $I=R_x \times (CT1/CT2)/1000$                 | A            | F12         |
| Power, demand               | $P=R_x \times (PT1/PT2) \times (CT1/CT2)$     | W            | F13         |
| Reactive power, demand      | $Q=R_x \times (PT1/PT2) \times (CT1/CT2)$     | Var          | F14         |
| Apparent power, demand      | $S=R_x \times (PT1/PT2) \times (CT1/CT2)$     | VA           | F15         |
| Power factor                | $PF=R_x/100$                                  | No unit      | F16         |
| Unbalance factor            | $Unbl=(R_x/10000) \times 100\%$               | No unit      | F17         |
| THD                         | $THD=(R_x/10000) \times 100\%$                | No unit      | F18         |
| Harmonics                   | $HDn=(R_x/10000) \times 100\%$                | No unit      | F19         |
| Total odd HD                | $HD_o=(R_x/10000) \times 100\%$               | No unit      | F20         |
| Total even HD               | $HD_e=(R_x/10000) \times 100\%$               | No unit      | F21         |
| Crest factor                | $CF=R_x/1000$                                 | No unit      | F22         |
| K factor                    | $KF=R_x/10$                                   | No unit      | F23         |
| THFF                        | $THFF=(R_x/10000) \times 100\%$               | No unit      | F24         |
| Phase angle                 | Phase angle= $R_x/10$                         | Degree       | F25         |

**IMPORTANT NOTE:** Regions from “System parameters settings” to “Data logging 3 settings” are the regions that can be set and modified. Please follow these guidelines when communicating with the meter.

1. When function code 10H is used, one communication command can only modify contents in one region, such as “System parameters settings,” “System status parameter,” “Date and time table,” “Over/under limit alarming-Global settings,” “Over/under limit alarming-settings,” I/O Modules settings,” or “Data logging 1 settings, Data logging 2 settings, Data logging 3 settings.”

Modification of the contents in both of two or more regions above cannot be accomplished in a single communication.

- When function code 03H is used, the rules and limitations described above will not be applied.

### 6.3.3 System Parameter Setting

System parameters determine how the meter works. Please refer to Chapter 3 and Chapter 4 for more details.

Function code: 03H for reading, 10H for writing.

Data type: word

Table 6-15

| System Status 03H Read, 10H Write |            |  |  |         |           |                 |
|-----------------------------------|------------|--|--|---------|-----------|-----------------|
| Address(H)                        | Address(D) | Parameter                              | Range  | Default | Data Type | Access Property |
| 0FFDH                             | 4093       | Frequency                              | 0: 50Hz<br>1: 60Hz<br>2: 400Hz                 | 0       | Word      | R/W             |
| 0FFEh                             | 4094       | First Communication Protocol           | 0: Modbus<br>1: DNP3.0                         | 0       | Word      | R/W             |
| 0FFFh                             | 4095       | Parity for Communication Protocol 1    | 0: Even<br>1: Odd<br>2: Non2<br>3: Non1        | 3       | Word      | R/W             |
| 1000H                             | 4096       | Password                               | 0~9999   | 0       | Word      | R/W             |
| 1001H                             | 4097       | Communication Address 1                | 1~247 (Modbus)<br>0~65534 (DNP3.0)             | 1       | Word      | R/W             |
| 1002H                             | 4098       | Baud Rate for Communication Protocol 1 | 1200~38400                                     | 19200   | Word      | R/W             |
| 1003H                             | 4099       | Voltage Input Wiring Type              | 0: 3LN<br>1: 1LN<br>2: 2LL<br>3: 3LL<br>4: 1LL | 0       | Word      | R/W             |
| 1004H                             | 4100       | Current Input Wiring Type              | 0: 3CT<br>1: 1CT<br>2: 2CT                     | 0       | Word      | R/W             |
| 1005H                             | 4101       | PT1 (High 16 bit)                      | 50.0~500000.0                                  | 0       | Word      | R/W             |
| 1006H                             | 4102       | PT2 (Low 16 bit)                       |  | 400     | Word      | R/W             |

## Acuvim II Series Power Meter

| System Status 03H Read, 10H Write |            |                            |   |   |           |                 |
|-----------------------------------|------------|----------------------------|---|---|-----------|-----------------|
| Address(H)                        | Address(D) | Parameter                  | Range   | Default   | Data Type | Access Property |
| 1007H                             | 4103       | PT2                        | 50.0~400.0  | 400   | Word      | R/W             |
| 1008H                             | 4104       | CT1                        | 1~50000   | CT1 = 5, for 5A<br>CT1 = 1, for 333mV<br>CT1 = 1, for 80/100/200mA<br>CT1 = 1000, for RCT                 | Word      | R/W             |
| 1009H                             | 4105       | CT2                        | 1(A), 5(A), 333 (333mV), 80, 100, 200 (mA)                              | CT2 = 5, for 5A<br>CT2 = 333, for 333mV<br>CT2 = 100, for 80/100/200mA<br>CT2 = 120/60 or 100/50, for RCT | Word      | R/W             |
| 100AH                             | 4106       | kWh Pulse Constant         | 1~60000   | 5000  | Word      | R/W             |
| 100BH                             | 4107       | kvarh Pulse Constant       | 1~60000   | 5000  | Word      | R/W             |
| 100CH                             | 4108       | LCD Backlight Time         | 0-120   | 1   | Word      | R/W             |
| 100DH                             | 4109       | Demand Sliding Window Time | 1~30  | 15  | Word      | R/W             |
| 100EH                             | 4110       | Demand Calculation Mode    | 0: Fixed Window<br>1: Sliding Window<br>2: Thermal<br>3: Rolling Window | 1   | Word      | R/W             |
| 100FH                             | 4111       | Clear Demand               | Only 1 works  | 0   | Word      | R/W             |
| 1010H                             | 4112       | Max/Min Clear              | Only 1 works  | 0   | Word      | R/W             |
| 1011H                             | 4113       | Run Time Clear             | Only 1 works  | 0   | Word      | R/W             |
| 1012H                             | 4114       | Current I1 Direction       | 0: Positive<br>1: Negative  | 0   | Word      | R/W             |
| 1013H                             | 4115       | Current I2 Direction       | 0: Positive<br>1: Negative  | 0   | Word      | R/W             |
| 1014H                             | 4116       | Current I3 Direction       | 0: Positive<br>1: Negative  | 0   | Word      | R/W             |
| 1015H                             | 4117       | VAR/PF Convention          | 0: IEC<br>1: IEEE   | 0   | Word      | R/W             |
| 1016H                             | 4118       | Clear Energy               | Only 1 works  | 0   | Word      | R/W             |
| 1017H                             | 4119       | Energy Calculation Mode    | 0: Fundamental<br>1: Full wave  | 1   | Word      | R/W             |

| System Status 03H Read, 10H Write |            |                                  |   |         |           |                 |
|-----------------------------------|------------|----------------------------------|---|---------|-----------|-----------------|
| Address(H)                        | Address(D) | Parameter                        | Range   | Default | Data Type | Access Property |
| 1018H                             | 4120       | Reactive Power Measurement Mode  | 0: Real<br>1: General   | 0       | Word      | R/W             |
| 1019H                             | 4121       | Energy Display Mode              | 0: Primary<br>1: Secondary  | 0       | Word      | R/W             |
| 101AH                             | 4122       | Reset Ethernet Module            | 0: None<br>1: Reset<br>2: Default   | 0       | Word      | R/W             |
| 101BH                             | 4123       | Enable SOE                       | 0: None<br>1: AXM-IO11<br>2: AXM-IO21<br>3: AXM-IO31<br>4: AXM-IO12<br>5: AXM-IO22<br>6: AXM-IO32 | 0       | Word      | R/W             |
| 101CH                             | 4124       | Clear Pulse Counter              | 0: None<br>1: AXM-IO11<br>2: AXM-IO21<br>3: AXM-IO31<br>4: AXM-IO12<br>5: AXM-IO22<br>6: AXM-IO32 | 0       | Word      | R/W             |
| 101DH                             | 4125       | Basic Parameter Mode             | 0: Secondary<br>1: Primary  | 0       | Word      | R/W             |
| 1020H                             | 4128       | Demand Calculation Slipping Time | 1~30  | 1       | Word      | R/W             |

**NOTE:**

1. When register 0FFEh is 0, the first communication protocol is set to MODBUS. When register 0FFEh is 1, the first communication protocol is set to DNP3.0. At this time, special DNP3.0 software is needed.
2. 100AH, 100BH setting method:  $1000 * 3600 / (U * I * n * \text{pulse constant}) = \text{pulse period (S)}$ , pulse period calculated by the pulse constant must be greater than the pulse width (20ms ~ 1000ms) of IO module DO setting, wherein n is applied with the user, and if the three-phase signals are added, then n is 3. U and I generally equal to user settings PT2 and CT2, i.e., rated voltage and rated current.
3. 0x1017H: When selecting 400Hz type; supports full-wave only.

### 6.3.4 System Status Parameters

The “System status” indicates the events that have occurred in the meter, what kinds of flags are read by the user, and the index of the storage events. Flags should be cleared after being read by the controller; otherwise, new data will not be stored properly.

Function code: 03H for reading, 10H for writing.

Data type: word

Table 6-16

| System Status 03H Read, 10H Write |            |                                |   |         |           |                 |
|-----------------------------------|------------|--------------------------------|---|---------|-----------|-----------------|
| Address(H)                        | Address(D) | Parameter                      | Range   | Default | Data Type | Access Property |
| 101EH                             | 4126       | Sealed Non Standard Parameters | Bit0: 1st communication parameters<br>Bit1: 2nd communication parameters<br>Bit2: Clear Run time<br>Bit3: DI Pulse count<br>Bit4: TOU |         | Word      | R/W             |
| 101FH                             | 4127       | Seal Status                    | 0x0A: Sealed<br>Other: Seal opened  |         | Word      | R/W             |
| 1020H                             | 4128       | Reserved                       |   |         | Word      | R/W             |
| 1021H                             | 4129       | Clear Alarm Record             | 0x0A: Clear<br>Other: Not Clear   |         | Word      | R/W             |
| 1022H-102DH                       | 4130-4141  | Reserved                       |   |         | Word      | R/W             |
| 102EH                             | 4142       | System Status                  | Bit0: New alarm record<br>Bit1: New SOE record  |         | Word      | R/W             |
| 102FH                             | 4143       | Baud Rate 2                    | 4800~38400  | 38400   | Word      | R/W             |
| 1030H                             | 4144       | Parity 2                       | 0: Even<br>1: Odd<br>2: Non2<br>3: Non1   | 3       | Word      | R/W             |
| 1031H                             | 4145       | Communication Address 2        | 1~247   | 1       | Word      | R/W             |
| 1032H                             | 4146       | Alarm Record Number            | 0: No alarming record<br>1~16: Last alarm record number   |         | Word      | R/W             |
| 1033H                             | 4147       | SOE Record Number              | 0: No SOE record<br>1~20: Last SOE record number  |         | Word      | R/W             |
| 1034H                             | 4148       | Run Time (High)                | 0~999999999   |         | Word      | R/W             |
| 1035H                             | 4149       | Run Time (Low)                 |   |         | Word      | R/W             |

| System Status 03H Read, 10H Write |            |                                |   |         |           |                 |
|-----------------------------------|------------|--------------------------------|---|---------|-----------|-----------------|
| Address(H)                        | Address(D) | Parameter                      | Range   | Default | Data Type | Access Property |
| 1036H                             | 4150       | Expansion IO Modules Status    | Bit0: AXM-IO11<br>Bit1: AXM-IO12<br>Bit2: AXM-IO21<br>Bit3: AXM-IO22<br>Bit4: AXM-IO31<br>Bit5: AXM-IO32<br>0: Disconnected<br>1: Connected |         | Word      | R/W             |
| 1037H                             | 4151       | Reserved                       |   |         | Word      | R/W             |
| 1038H                             | 4152       | 2nd Communication Selection    | 0: Other Protocol<br>1: BACnet Protocol<br>2: Mesh Protocol<br>3: Wi-Fi   | 0       | Word      | R/W             |
| 1039H                             | 4153       | 10 Year Holiday Setting Enable | 1: Enable   |         | Word      | R/W             |
| 103AH                             | 4154       | Clear Sharp Tariff             | 0x0A: Clear<br>Other: Not Clear   |         | Word      | R/W             |
| 103BH                             | 4155       | Clear Peak Tariff              | 0x0A: Clear<br>Other: Not Clear   |         | Word      | R/W             |
| 103CH                             | 4156       | Clear Valley Tariff            | 0x0A: Clear<br>Other: Not Clear   |         | Word      | R/W             |
| 103DH                             | 4157       | Clear Normal Tariff            | 0x0A: Clear<br>Other: Not Clear   |         | Word      | R/W             |
| 103EH                             | 4158       | Clear Total                    | 0x0A: Clear<br>Other: Not Clear   |         | Word      | R/W             |

**NOTE:**

1. Please refer to Chapter 3 and Chapter 4 for more details about parameter settings.
2. When register 1038H is 2, second communication is set to MESH, the baud rate should be set to "9600bps," and parity should be set to "NON1" for the second communication. When register 1038H is 1, the second communication protocol is set to BACnet protocol. When register 1038H is 0, the second communication protocol is set to other protocols, while second communication should select the second RS-485 module, PROFIBUS module, or Ethernet module. If the selected protocol does not match attached module, communication cannot process. If you use the Ethernet or PROFIBUS module, you should set 38400bps and NON1 for the second communication. While the Ethernet or PROFIBUS module will connect normally, the user cannot change the protocol, baud rate, or parity.

### 6.3.5 Date and Time Registers

Function code: 03H for reading, 10H for presetting.

Table 6-17

| Clock Settings: 03H Read, 10H Write |            |           |           |           |                 |
|-------------------------------------|------------|-----------|-----------|-----------|-----------------|
| Address(H)                          | Address(D) | Parameter | Range     | Data Type | Access Property |
| 103FH                               | 4159       | Week      | 0~6       | Word      | R/W             |
| 1040H                               | 4160       | Year      | 2000~2099 | Word      | R/W             |
| 1041H                               | 4161       | Month     | 1~12      | Word      | R/W             |
| 1042H                               | 4162       | Day       | 1~31      | Word      | R/W             |
| 1043H                               | 4163       | Hour      | 0-23      | Word      | R/W             |
| 1044H                               | 4164       | Minute    | 0-59      | Word      | R/W             |
| 1045H                               | 4165       | Second    | 0-59      | Word      | R/W             |

### 6.3.6 100ms Refresh Metering Parameters

Table 6-18

| Basic Measurements: 03H Read |             |        |                       |                |                |          |           |                 |
|------------------------------|-------------|--------|-----------------------|----------------|----------------|----------|-----------|-----------------|
| Address(H)                   | Address(D)  | Symbol | Parameter             | Parameter Mode |                | Property | Data Type | Access Property |
|                              |             |        |                       | Primary Mode   | Secondary Mode |          |           |                 |
| 3000H-3001H                  | 12288-12289 | F      | Frequency             | F=Rx           | F=Rx           | Hz       | Float     | R               |
| 3002H-3003H                  | 12290-12291 | U1     | Phase 1 Voltage       | U=Rx           | U=Rx*(PT1/PT2) | V        | Float     | R               |
| 3004H-3005H                  | 12292-12293 | U2     | Phase 2 Voltage       | U=Rx           | U=Rx*(PT1/PT2) | V        | Float     | R               |
| 3006H-3007H                  | 12294-12295 | U3     | Phase 3 Voltage       | U=Rx           | U=Rx*(PT1/PT2) | V        | Float     | R               |
| 3008H-3009H                  | 12296-12297 | Uavg   | Average Phase Voltage | U=Rx           | U=Rx*(PT1/PT2) | V        | Float     | R               |
| 300AH-300BH                  | 12298-12299 | U12    | Line Voltage 1-2      | U=Rx           | U=Rx*(PT1/PT2) | V        | Float     | R               |
| 300CH-300DH                  | 12300-12301 | U23    | Line Voltage 2-3      | U=Rx           | U=Rx*(PT1/PT2) | V        | Float     | R               |
| 300EH-300FH                  | 12302-12303 | U31    | Line Voltage 3-1      | U=Rx           | U=Rx*(PT1/PT2) | V        | Float     | R               |
| 3010H-3011H                  | 12304-12305 | U1avg  | Average Line Voltage  | U=Rx           | U=Rx*(PT1/PT2) | V        | Float     | R               |

| Basic Measurements: 03H Read |             |        |                        |                |                                   |          |           |                 |  |
|------------------------------|-------------|--------|------------------------|----------------|-----------------------------------|----------|-----------|-----------------|--|
| Address(H)                   | Address(D)  | Symbol | Parameter              | Parameter Mode |                                   | Property | Data Type | Access Property |  |
|                              |             |        |                        | Primary Mode   | Secondary Mode                    |          |           |                 |  |
| 3012H-3013H                  | 12306-12307 | IL1    | Total Phase A Current  | I=Rx           | $I=Rx*(CT1/CT2)$                  | A        | Float     | R               |  |
| 3014H-3015H                  | 12308-12309 | IL2    | Total Phase B Current  | I=Rx           | $I=Rx*(CT1/CT2)$                  | A        | Float     | R               |  |
| 3016H-3017H                  | 12310-12311 | IL3    | Total Phase C Current  | I=Rx           | $I=Rx*(CT1/CT2)$                  | A        | Float     | R               |  |
| 3018H-3019H                  | 12312-12313 | Iavg   | Average Phase Current  | I=Rx           | $I=Rx*(CT1/CT2)$                  | A        | Float     | R               |  |
| 301AH-301BH                  | 12314-12315 | In     | Neutral Current        | I=Rx           | $I=Rx*(CT1/CT2)$                  | A        | Float     | R               |  |
| 301CH-301DH                  | 12316-12317 | Pa     | Phase A Power          | $P=Rx/1000$    | $P=[Rx*(PT1/PT2)*(CT1/CT2)]/1000$ | kW       | Float     | R               |  |
| 301EH-301FH                  | 12318-12319 | Pb     | Phase B Power          | $P=Rx/1000$    | $P=[Rx*(PT1/PT2)*(CT1/CT2)]/1000$ | kW       | Float     | R               |  |
| 3020H-3021H                  | 12320-12321 | Pc     | Phase C Power          | $P=Rx/1000$    | $P=[Rx*(PT1/PT2)*(CT1/CT2)]/1000$ | kW       | Float     | R               |  |
| 3022H-3023H                  | 12322-12323 | Psum   | Total System Power     | $P=Rx/1000$    | $P=[Rx*(PT1/PT2)*(CT1/CT2)]/1000$ | kW       | Float     | R               |  |
| 3024H-3025H                  | 12324-12325 | Qa     | Phase A Reactive Power | $Q=Rx/1000$    | $Q=[Rx*(PT1/PT2)*(CT1/CT2)]/1000$ | kvar     | Float     | R               |  |
| 3026H-3027H                  | 12326-12327 | Qb     | Phase B Reactive Power | $Q=Rx/1000$    | $Q=[Rx*(PT1/PT2)*(CT1/CT2)]/1000$ | kvar     | Float     | R               |  |
| 3028H-3029H                  | 12328-12329 | Qc     | Phase C Reactive Power | $Q=Rx/1000$    | $Q=[Rx*(PT1/PT2)*(CT1/CT2)]/1000$ | kvar     | Float     | R               |  |
| 302AH-302BH                  | 12330-12331 | Qsum   | Total Reactive Power   | $Q=Rx/1000$    | $Q=[Rx*(PT1/PT2)*(CT1/CT2)]/1000$ | kvar     | Float     | R               |  |
| 302CH-302DH                  | 12332-12333 | Sa     | Phase A Apparent Power | $S=Rx/1000$    | $S=[Rx*(PT1/PT2)*(CT1/CT2)]/1000$ | kVA      | Float     | R               |  |
| 302EH-302FH                  | 12334-12335 | Sb     | Phase B Apparent Power | $S=Rx/1000$    | $S=[Rx*(PT1/PT2)*(CT1/CT2)]/1000$ | kVA      | Float     | R               |  |
| 3030H-3031H                  | 12336-12337 | Sc     | Phase C Apparent Power | $S=Rx/1000$    | $S=[Rx*(PT1/PT2)*(CT1/CT2)]/1000$ | kVA      | Float     | R               |  |

## Acuvim II Series Power Meter

| Basic Measurements: 03H Read |             |        |                      |                |                                    |          |           |                 |
|------------------------------|-------------|--------|----------------------|----------------|------------------------------------|----------|-----------|-----------------|
| Address(H)                   | Address(D)  | Symbol | Parameter            | Parameter Mode |                                    | Property | Data Type | Access Property |
|                              |             |        |                      | Primary Mode   | Secondary Mode                     |          |           |                 |
| 3032H-3033H                  | 12338-12339 | Ssum   | Total Apparent Power | $S=R_x/1000$   | $S=[R_x*(PT1/PT2)*(CT1/CT2)]/1000$ | kVA      | Float     | R               |
| 3034H-3035H                  | 12340-12341 | PFa    | Phase A Power Factor | PF=Rx          | PF=Rx                              |          | Float     | R               |
| 3036H-3037H                  | 12342-12343 | PFb    | Phase B Power Factor | PF=Rx          | PF=Rx                              |          | Float     | R               |
| 3038H-3039H                  | 12344-12345 | PFc    | Phase C Power Factor | PF=Rx          | PF=Rx                              |          | Float     | R               |
| 3403AH-303BH                 | 12346-12347 | PFsum  | Total Power Factor   | PF=Rx          | PF=Rx                              |          | Float     | R               |

### 6.3.7 Real Time Metering Parameters

There are two, different modes to read basic analog measurements. The first is secondary mode and the other is primary mode. In primary mode, the numerical value in the register of the meter is equal to the real, physical value. In secondary mode, the relationship between the numerical value in the register and the real physical value is shown in the following table. (Rx is the numerical value in the register of the Acuvim II Series meter).

**NOTE:** The parameter mode Primary or Secondary corresponds to the Basic Parameter Mode (at address 101DH) in the system parameter settings. You can also configure the parameter mode from the 'S28 PARA MODE' in the system settings through the meter's display. The basic parameter mode of the meter is in Secondary Mode by default.

Table 6-19

| Energy Measurements: 03H Read, 10H Write |             |        |                       |                |                   |          |           |                 |
|--|-------------|--------|-----------------------|----------------|-------------------|----------|-----------|-----------------|
| Address(H)                               | Address(D)  | Symbol | Parameter             | Parameter Mode |                   | Property | Data Type | Access Property |
|  |             |        |                       | Primary Mode   | Secondary Mode    |          |           |                 |
| 4000H-4001H                              | 16384-16385 | F      | Frequency             | F=Rx           | F=Rx              | Hz       | Float     | R               |
| 4002H-4003H                              | 16386-16387 | U1     | Phase 1 Voltage       | U=Rx           | $U=R_x*(PT1/PT2)$ | V        | Float     | R               |
| 4004H-4005H                              | 16388-16389 | U2     | Phase 2 Voltage       | U=Rx           | $U=R_x*(PT1/PT2)$ | V        | Float     | R               |
| 4006H-4007H                              | 16390-16391 | U3     | Phase 3 Voltage       | U=Rx           | $U=R_x*(PT1/PT2)$ | V        | Float     | R               |
| 4008H-4009H                              | 16392-16393 | Uavg   | Average Phase Voltage | U=Rx           | $U=R_x*(PT1/PT2)$ | V        | Float     | R               |

| Energy Measurements: 03H Read, 10H Write |             |        |                        |                |                                   |          |           |                 |
|--|-------------|--------|------------------------|----------------|-----------------------------------|----------|-----------|-----------------|
| Address(H)                               | Address(D)  | Symbol | Parameter              | Parameter Mode |                                   | Property | Data Type | Access Property |
|  |             |        |                        | Primary Mode   | Secondary Mode                    |          |           |                 |
| 400AH-400BH                              | 16394-16395 | U12    | Line Voltage 1-2       | U=Rx           | $U=Rx*(PT1/PT2)$                  | V        | Float     | R               |
| 400CH-400DH                              | 16396-16397 | U23    | Line Voltage 2-3       | U=Rx           | $U=Rx*(PT1/PT2)$                  | V        | Float     | R               |
| 400EH-400FH                              | 16398-16399 | U31    | Line Voltage 3-1       | U=Rx           | $U=Rx*(PT1/PT2)$                  | V        | Float     | R               |
| 4010H-4011H                              | 16400-16401 | Uavg   | Average Line Voltage   | U=Rx           | $U=Rx*(PT1/PT2)$                  | V        | Float     | R               |
| 4012H-4013H                              | 16402-16403 | IL1    | Total Phase A Current  | I=Rx           | $I=Rx*(CT1/CT2)$                  | A        | Float     | R               |
| 4014H-4015H                              | 16404-16405 | IL2    | Total Phase B Current  | I=Rx           | $I=Rx*(CT1/CT2)$                  | A        | Float     | R               |
| 4016H-4017H                              | 16406-16407 | IL3    | Total Phase C Current  | I=Rx           | $I=Rx*(CT1/CT2)$                  | A        | Float     | R               |
| 4018H-4019H                              | 16408-16409 | Iavg   | Average Phase Current  | I=Rx           | $I=Rx*(CT1/CT2)$                  | A        | Float     | R               |
| 401AH-401BH                              | 16410-16411 | In     | Neutral Current        | I=Rx           | $I=Rx*(CT1/CT2)$                  | A        | Float     | R               |
| 401CH-401DH                              | 16412-16413 | Pa     | Phase A Power          | $P=Rx/1000$    | $P=[Rx*(PT1/PT2)*(CT1/CT2)]/1000$ | kW       | Float     | R               |
| 401EH-401FH                              | 16414-16415 | Pb     | Phase B Power          | $P=Rx/1000$    | $P=[Rx*(PT1/PT2)*(CT1/CT2)]/1000$ | kW       | Float     | R               |
| 4020H-4021H                              | 16416-16417 | Pc     | Phase C Power          | $P=Rx/1000$    | $P=[Rx*(PT1/PT2)*(CT1/CT2)]/1000$ | kW       | Float     | R               |
| 4022H-4023H                              | 16418-16419 | Psum   | Total System Power     | $P=Rx/1000$    | $P=[Rx*(PT1/PT2)*(CT1/CT2)]/1000$ | kW       | Float     | R               |
| 4024H-4025H                              | 16420-16421 | Qa     | Phase A Reactive Power | $Q=Rx/1000$    | $Q=[Rx*(PT1/PT2)*(CT1/CT2)]/1000$ | kvar     | Float     | R               |
| 4026H-4027H                              | 16422-16423 | Qb     | Phase B Reactive Power | $Q=Rx/1000$    | $Q=[Rx*(PT1/PT2)*(CT1/CT2)]/1000$ | kvar     | Float     | R               |
| 4028H-4029H                              | 16424-16425 | Qc     | Phase C Reactive Power | $Q=Rx/1000$    | $Q=[Rx*(PT1/PT2)*(CT1/CT2)]/1000$ | kvar     | Float     | R               |
| 402AH-402BH                              | 16426-16427 | Qsum   | Total Reactive Power   | $Q=Rx/1000$    | $Q=[Rx*(PT1/PT2)*(CT1/CT2)]/1000$ | kvar     | Float     | R               |

## Acuvim II Series Power Meter

| Energy Measurements: 03H Read, 10H Write |             |        |                        |                               |                                    |          |           |                 |  |
|--|-------------|--------|------------------------|-------------------------------|------------------------------------|----------|-----------|-----------------|--|
| Address(H)                               | Address(D)  | Symbol | Parameter              | Parameter Mode                |                                    | Property | Data Type | Access Property |  |
|  |             |        |                        | Primary Mode                  | Secondary Mode                     |          |           |                 |  |
| 402CH-402DH                              | 16428-16429 | Sa     | Phase A Apparent Power | $S=R_x/1000$                  | $S=[R_x*(PT1/PT2)*(CT1/CT2)]/1000$ | kVA      | Float     | R               |  |
| 402EH-402FH                              | 16430-16431 | Sb     | Phase B Apparent Power | $S=R_x/1000$                  | $S=[R_x*(PT1/PT2)*(CT1/CT2)]/1000$ | kVA      | Float     | R               |  |
| 4030H-4031H                              | 16432-16433 | Sc     | Phase C Apparent Power | $S=R_x/1000$                  | $S=[R_x*(PT1/PT2)*(CT1/CT2)]/1000$ | kVA      | Float     | R               |  |
| 4032H-4033H                              | 16434-16435 | Ssum   | Total Apparent Power   | $S=R_x/1000$                  | $S=[R_x*(PT1/PT2)*(CT1/CT2)]/1000$ | kVA      | Float     | R               |  |
| 4034H-4035H                              | 16436-16437 | PFa    | Phase A Power Factor   | $PF=R_x$                      | $PF=R_x$                           |          | Float     | R               |  |
| 4036H-4037H                              | 16438-16439 | PFb    | Phase B Power Factor   | $PF=R_x$                      | $PF=R_x$                           |          | Float     | R               |  |
| 4038H-4039H                              | 16440-16441 | PFc    | Phase C Power Factor   | $PF=R_x$                      | $PF=R_x$                           |          | Float     | R               |  |
| 403AH-403BH                              | 16442-16443 | PFsum  | Total Power Factor     | $PF=R_x$                      | $PF=R_x$                           |          | Float     | R               |  |
| 403CH-403DH                              | 16444-16445 | U_unbl | Voltage Unbalance      | $U=R_x*100\%$                 | $U=R_x*100\%$                      | %        | Float     | R               |  |
| 403EH-403FH                              | 16446-16447 | I_unbl | Current Unbalance      | $I=R_x*100\%$                 | $I=R_x*100\%$                      | %        | Float     | R               |  |
| 4040H-4041H                              | 16448-16449 | L/C/R  | Load Characteristic    | 76.0(L)<br>67.0(C)<br>82.0(R) | 76.0(L)<br>67.0(C)<br>82.0(R)      |          | Float     | R               |  |
| 4042H-4043H                              | 16450-16451 | P_Dmd  | Power Demand           | $P=R_x/1000$                  | $P=[R_x*(PT1/PT2)*(CT1/CT2)]/1000$ | kW       | Float     | R               |  |
| 4044H-4045H                              | 16452-16453 | Q_Dmd  | Reactive Power Demand  | $S=R_x/1000$                  | $S=[R_x*(PT1/PT2)*(CT1/CT2)]/1000$ | kVA      | Float     | R               |  |
| 4046H-4047H                              | 16454-16455 | S_Dmd  | Apparent Power Demand  | $Q=R_x/1000$                  | $Q=[R_x*(PT1/PT2)*(CT1/CT2)]/1000$ | kvar     | Float     | R               |  |
| 4600H-4601H                              | 17920-17921 | I1_Dmd | Phase A Current Demand | $I=R_x$                       | $I=R_x*(CT1/CT2)$                  | A        | Float     | R               |  |
| 4602H-4603H                              | 17922-17923 | I2_Dmd | Phase B Current Demand | $I=R_x$                       | $I=R_x*(CT1/CT2)$                  | A        | Float     | R               |  |
| 4604H-4605H                              | 17924-17925 | I3_Dmd | Phase C Current Demand | $I=R_x$                       | $I=R_x*(CT1/CT2)$                  | A        | Float     | R               |  |

### 6.3.8 Energy Parameters

**NOTE:** The Energy Display option of either Primary Mode or Secondary Mode corresponds to the Energy Display Mode (at address 1019H) in the system parameter settings. You can also configure the energy display mode from the 'S24 E SEL' in the system settings through the meters display. The energy display mode is in Primary Mode by default.

Table 6-20

| Energy Measurements: 03H Read, 10H Write |             |         |                           |                |                 |             |           |                 |
|--|-------------|---------|---------------------------|----------------|-----------------|-------------|-----------|-----------------|
| Address(H)                               | Address(D)  | Symbol  | Parameter                 | Parameter Mode |                 | Property    | Data Type | Access Property |
|  |             |         |                           | Primary Mode   | Secondary Mode  |             |           |                 |
| 4048H-4049H                              | 16456-16457 | Ep_Imp  | Consumed Energy           | Ep_Imp=Rx/10   | Ep_Imp=Rx/1000  | 0~999999999 | kWh       | R/W             |
| 404AH-404BH                              | 16458-16459 | Ep_Exp  | Generated Energy          | Ep_Exp=Rx/10   | Ep_Exp=Rx/1000  | 0~999999999 | kWh       | R/W             |
| 404CH-404DH                              | 16460-16461 | Eq_Imp  | Consumed Reactive Energy  | Eq_Imp=Rx/10   | Eq_Imp=Rx/1000  | 0~999999999 | kvarh     | R/W             |
| 404EH-404FH                              | 16462-16463 | Eq_Exp  | Generated Reactive Energy | Eq_Exp=Rx/10   | Eq_Exp=Rx/1000  | 0~999999999 | kvarh     | R/W             |
| 4050H-4051H                              | 16464-16465 | Ep_sum  | Total Energy              | Ep_sum=Rx/10   | Ep_sum=Rx/1000  | 0~999999999 | kWh       | R/W             |
| 4052H-4053H                              | 16466-16467 | Ep_net  | Net Energy                | Ep_net=Rx/10   | Ep_net=Rx/1000  | ±999999999  | kWh       | R/W             |
| 4054H-4055H                              | 16468-16469 | Eq_sum  | Total Reactive Energy     | Eq_sum=Rx/10   | Eq_sum=Rx/1000  | 0~999999999 | kvarh     | R/W             |
| 4056H-4057H                              | 16470-16471 | Eq_net  | Net Reactive Energy       | Eq_net=Rx/10   | Eq_net=Rx/1000  | ±999999999  | kvarh     | R/W             |
| 4058H-4059H                              | 16472-16473 | Es      | Apparent Energy           | Es=Rx/10       | Es=Rx/1000      | 0~999999999 | kVAh      | R/W             |
| 4620H-4621H                              | 17952-17953 | Epa_Imp | Phase A Consumed Energy   | Epa_Imp=Rx/10  | Epa_Imp=Rx/1000 | 0~999999999 | kWh       | R/W             |
| 4622H-4623H                              | 17954-17955 | Epa_Exp | Phase A Generated Energy  | Epa_Exp=Rx/10  | Epa_Exp=Rx/1000 | 0~999999999 | kWh       | R/W             |
| 4624H-4625H                              | 17956-17957 | Epb_Imp | Phase B Consumed Energy   | Epb_Imp=Rx/10  | Epb_Imp=Rx/1000 | 0~999999999 | kWh       | R/W             |
| 4626H-4627H                              | 17958-17959 | Epb_Exp | Phase B Generated Energy  | Epb_Exp=Rx/10  | Epb_Exp=Rx/1000 | 0~999999999 | kWh       | R/W             |

## Acuvim II Series Power Meter

| Energy Measurements: 03H Read, 10H Write |             |         |                                   |                |                 |             |           |                 |
|--|-------------|---------|-----------------------------------|----------------|-----------------|-------------|-----------|-----------------|
| Address(H)                               | Address(D)  | Symbol  | Parameter                         | Parameter Mode |                 | Property    | Data Type | Access Property |
|  |             |         |                                   | Primary Mode   | Secondary Mode  |             |           |                 |
| 4628H-4629H                              | 17960-17961 | Epc_Imp | Phase C Consumed Energy           | Epc_Imp=Rx/10  | Epc_Imp=Rx/1000 | 0~999999999 | kWh       | R/W             |
| 462AH-462BH                              | 17962-17963 | Epc_Exp | Phase C Generated Energy          | Epc_Exp=Rx/10  | Epc_Exp=Rx/1000 | 0~999999999 | kWh       | R/W             |
| 462CH-462DH                              | 17964-17965 | Eqa_Imp | Phase A Consumed Reactive Energy  | Eqa_Imp=Rx/10  | Eqa_Imp=Rx/1000 | 0~999999999 | kvarh     | R/W             |
| 462EH-462FH                              | 17966-17967 | Eqa_Exp | Phase A Generated Reactive Energy | Eqa_Exp=Rx/10  | Eqa_Exp=Rx/1000 | 0~999999999 | kvarh     | R/W             |
| 4630H-4631H                              | 17968-17969 | Eqb_Imp | Phase B Consumed Reactive Energy  | Eqb_Imp=Rx/10  | Eqb_Imp=Rx/1000 | 0~999999999 | kvarh     | R/W             |
| 4632H-4633H                              | 17970-17971 | Eqb_Exp | Phase B Generated Reactive Energy | Eqb_Exp=Rx/10  | Eqb_Exp=Rx/1000 | 0~999999999 | kvarh     | R/W             |
| 4634H-4635H                              | 17972-17973 | Eqc_Imp | Phase C Consumed Reactive Energy  | Eqc_Imp=Rx/10  | Eqc_Imp=Rx/1000 | 0~999999999 | kvarh     | R/W             |
| 4636H-4637H                              | 17974-17975 | Eqc_Exp | Phase C Generated Reactive Energy | Eqc_Exp=Rx/10  | Eqc_Exp=Rx/1000 | 0~999999999 | kvarh     | R/W             |
| 4638H-4639H                              | 17976-17977 | Esa     | Phase A Apparent Energy           | Esa=Rx/10      | Esa=Rx/1000     | 0~999999999 | kVA       | R/W             |
| 463AH-463BH                              | 17978-17979 | Esb     | Phase B Apparent Energy           | Esb=Rx/10      | Esb=Rx/1000     | 0~999999999 | kVA       | R/W             |
| 463CH-463DH                              | 17980-17981 | Esc     | Phase C Apparent Energy           | Esc=Rx/10      | Esc=Rx/1000     | 0~999999999 | kVA       | R/W             |

## 6.3.9 TOU (Time-of-Use) Registers

## Current Month Accumulation TOU Energy

Table 6-21

| Current month accumulation TOU Energy: 03H Read, 10H Write |             |        |                           |             |          |           |                 |
|--|-------------|--------|---------------------------|-------------|----------|-----------|-----------------|
| Address(H)   | Address(D)  | Symbol | Parameter                 | Range       | Property | Data Type | Access Property |
| <b>Sharp</b>   |             |        |                           |             |          |           |                 |
| 7200H-7201H  | 29184-29185 | Ep_Imp | Consumed Energy           | 0-999999999 | kWh      | Dword     | R/W             |
| 7202H-7203H  | 29186-29187 | Ep_Exp | Generated Energy          | 0-999999999 | kWh      | Dword     | R/W             |
| 7204H-7205H  | 29188-29189 | Eq_Imp | Consumed Reactive Energy  | 0-999999999 | kvarh    | Dword     | R/W             |
| 7206H-7207H  | 29190-29191 | Eq_Exp | Generated Reactive Energy | 0-999999999 | kvarh    | Dword     | R/W             |
| 7208H-7209H  | 29192-29193 | Es     | Apparent Energy           | 0-999999999 | kVAh     | Dword     | R/W             |
| <b>Peak</b>  |             |        |                           |             |          |           |                 |
| 720AH-720BH  | 29194-29195 | Ep_Imp | Consumed Energy           | 0-999999999 | kWh      | Dword     | R/W             |
| 720CH-720DH  | 29196-29197 | Ep_Exp | Generated Energy          | 0-999999999 | kWh      | Dword     | R/W             |
| 720EH-720FH  | 29198-29199 | Eq_Imp | Consumed Reactive Energy  | 0-999999999 | kvarh    | Dword     | R/W             |
| 7210H-7211H  | 29200-29201 | Eq_Exp | Generated Reactive Energy | 0-999999999 | kvarh    | Dword     | R/W             |
| 7212H-7213H  | 29202-29203 | Es     | Apparent Energy           | 0-999999999 | kVAh     | Dword     | R/W             |
| <b>Valley</b>  |             |        |                           |             |          |           |                 |
| 7214H-7215H  | 29204-29205 | Ep_Imp | Consumed Energy           | 0-999999999 | kWh      | Dword     | R/W             |
| 7216H-7217H  | 29206-29207 | Ep_Exp | Generated Energy          | 0-999999999 | kWh      | Dword     | R/W             |
| 7218H-7219H  | 29208-29209 | Eq_Imp | Consumed Reactive Energy  | 0-999999999 | kvarh    | Dword     | R/W             |
| 721AH-721BH  | 29210-29211 | Eq_Exp | Generated Reactive Energy | 0-999999999 | kvarh    | Dword     | R/W             |
| 721CH-721DH  | 29212-29213 | Es     | Apparent Energy           | 0-999999999 | kVAh     | Dword     | R/W             |
| <b>Normal</b>  |             |        |                           |             |          |           |                 |
| 721EH-721FH  | 29214-29215 | Ep_Imp | Consumed Energy           | 0-999999999 | kWh      | Dword     | R/W             |

## Acuvim II Series Power Meter

| Current month accumulation TOU Energy: 03H Read, 10H Write |             |        |                           |             |          |           |                 |
|--|-------------|--------|---------------------------|-------------|----------|-----------|-----------------|
| Address(H)   | Address(D)  | Symbol | Parameter                 | Range       | Property | Data Type | Access Property |
| 7220H-7221H  | 29216-29217 | Ep_Exp | Generated Energy          | 0-999999999 | kWh      | Dword     | R/W             |
| 7222H-7223H  | 29218-29219 | Eq_Imp | Consumed Reactive Energy  | 0-999999999 | kvarh    | Dword     | R/W             |
| 7224H-7225H  | 29220-29221 | Eq_Exp | Generated Reactive Energy | 0-999999999 | kvarh    | Dword     | R/W             |
| 7226H-7227H  | 29222-29223 | Es     | Apparent Energy           | 0-999999999 | kVAh     | Dword     | R/W             |
| <b>Total</b>   |             |        |                           |             |          |           |                 |
| 7228H-7229H  | 29224-29225 | Ep_Imp | Consumed Energy           | 0-999999999 | kWh      | Dword     | R/W             |
| 722AH-722BH  | 29226-29227 | Ep_Exp | Generated Energy          | 0-999999999 | kWh      | Dword     | R/W             |
| 722CH-722DH  | 29228-29229 | Eq_Imp | Consumed Reactive Energy  | 0-999999999 | kvarh    | Dword     | R/W             |
| 722EH-722FH  | 29230-29231 | Eq_Exp | Generated Reactive Energy | 0-999999999 | kvarh    | Dword     | R/W             |
| 7230H-7231H  | 29232-29233 | Es     | Apparent Energy           | 0-999999999 | kVAh     | Dword     | R/W             |

## Prior Month Accumulation TOU Energy

Table 6-22

| Prior Month Accumulation TOU Energy: 03H Read, 10H Write |             |        |                           |             |          |           |                 |
|--|-------------|--------|---------------------------|-------------|----------|-----------|-----------------|
| Address(H)   | Address(D)  | Symbol | Parameter                 | Range       | Property | Data Type | Access Property |
| <b>Sharp</b>   |             |        |                           |             |          |           |                 |
| 7232H-7233H  | 29234-29235 | Ep_Imp | Consumed Energy           | 0-999999999 | kWh      | Dword     | R/W             |
| 7234H-7235H  | 29236-29237 | Ep_Exp | Generated Energy          | 0-999999999 | kWh      | Dword     | R/W             |
| 7236H-7237H  | 29238-29239 | Eq_Imp | Consumed Reactive Energy  | 0-999999999 | kvarh    | Dword     | R/W             |
| 7238H-7239H  | 29240-29241 | Eq_Exp | Generated Reactive Energy | 0-999999999 | kvarh    | Dword     | R/W             |
| 723AH-723BH  | 29242-29243 | Es     | Apparent Energy           | 0-999999999 | kVAh     | Dword     | R/W             |
| <b>Peak</b>  |             |        |                           |             |          |           |                 |
| 723CH-723DH  | 29244-29245 | Ep_Imp | Consumed Energy           | 0-999999999 | kWh      | Dword     | R/W             |

| Prior Month Accumulation TOU Energy: 03H Read, 10H Write |             |        |                           |             |          |           |                 |
|--|-------------|--------|---------------------------|-------------|----------|-----------|-----------------|
| Address(H)   | Address(D)  | Symbol | Parameter                 | Range       | Property | Data Type | Access Property |
| 723EH-723FH  | 29246-29247 | Ep_Exp | Generated Energy          | 0-999999999 | kWh      | Dword     | R/W             |
| 7240H-7241H  | 29248-29249 | Eq_Imp | Consumed Reactive Energy  | 0-999999999 | kvarh    | Dword     | R/W             |
| 7242H-7243H  | 29250-29251 | Eq_Exp | Generated Reactive Energy | 0-999999999 | kvarh    | Dword     | R/W             |
| 7244H-7245H  | 29252-29253 | Es     | Apparent Energy           | 0-999999999 | kVAh     | Dword     | R/W             |
| <b>Valley</b>  |             |        |                           |             |          |           |                 |
| 7246H-7247H  | 29254-29255 | Ep_Imp | Consumed Energy           | 0-999999999 | kWh      | Dword     | R/W             |
| 7248H-7249H  | 29256-29257 | Ep_Exp | Generated Energy          | 0-999999999 | kWh      | Dword     | R/W             |
| 724AH-724BH  | 29258-29259 | Eq_Imp | Consumed Reactive Energy  | 0-999999999 | kvarh    | Dword     | R/W             |
| 724CH-724DH  | 29260-29261 | Eq_Exp | Generated Reactive Energy | 0-999999999 | kvarh    | Dword     | R/W             |
| 724EH-724FH  | 29262-29263 | Es     | Apparent Energy           | 0-999999999 | kVAh     | Dword     | R/W             |
| <b>Normal</b>  |             |        |                           |             |          |           |                 |
| 7250H-7251H  | 29264-29265 | Ep_Imp | Consumed Energy           | 0-999999999 | kWh      | Dword     | R/W             |
| 7252H-7253H  | 29266-29267 | Ep_Exp | Generated Energy          | 0-999999999 | kWh      | Dword     | R/W             |
| 7254H-7255H  | 29268-29269 | Eq_Imp | Consumed Reactive Energy  | 0-999999999 | kvarh    | Dword     | R/W             |
| 7256H-7257H  | 29270-29271 | Eq_Exp | Generated Reactive Energy | 0-999999999 | kvarh    | Dword     | R/W             |
| 7258H-7259H  | 29272-29273 | Es     | Apparent Energy           | 0-999999999 | kVAh     | Dword     | R/W             |
| <b>Total</b>   |             |        |                           |             |          |           |                 |
| 725AH-725BH  | 29274-29275 | Ep_Imp | Consumed Energy           | 0-999999999 | kWh      | Dword     | R/W             |
| 725CH-725DH  | 29276-29277 | Ep_Exp | Generated Energy          | 0-999999999 | kWh      | Dword     | R/W             |
| 725EH-725FH  | 29278-29279 | Eq_Imp | Consumed Reactive Energy  | 0-999999999 | kvarh    | Dword     | R/W             |
| 7260H-7261H  | 29280-29281 | Eq_Exp | Generated Reactive Energy | 0-999999999 | kvarh    | Dword     | R/W             |
| 7262H-7263H  | 29282-29283 | Es     | Apparent Energy           | 0-999999999 | kVAh     | Dword     | R/W             |

Current Month Incremental TOU Energy

Table 6-23

| Current Month Incremental TOU Energy: 03H Read, 10H Write |             |        |                           |             |          |           |                 |
|---|-------------|--------|---------------------------|-------------|----------|-----------|-----------------|
| Address(H)  | Address(D)  | Symbol | Parameter                 | Range       | Property | Data Type | Access Property |
| <b>Sharp</b>  |             |        |                           |             |          |           |                 |
| 7300H-7301H   | 29440-29441 | Ep_Imp | Consumed Energy           | 0-999999999 | kWh      | Dword     | R/W             |
| 7302H-7303H   | 29442-29443 | Ep_Exp | Generated Energy          | 0-999999999 | kWh      | Dword     | R/W             |
| 7304H-7305H   | 29444-29445 | Eq_Imp | Consumed Reactive Energy  | 0-999999999 | kvarh    | Dword     | R/W             |
| 7306H-7307H   | 29446-29447 | Eq_Exp | Generated Reactive Energy | 0-999999999 | kvarh    | Dword     | R/W             |
| 7308H-7309H   | 29448-29449 | Es     | Apparent                  | 0-999999999 | kVAh     | Dword     | R/W             |
| <b>Peak</b>   |             |        |                           |             |          |           |                 |
| 730AH-730BH   | 29450-29451 | Ep_Imp | Consumed Energy           | 0-999999999 | kWh      | Dword     | R/W             |
| 730CH-730DH   | 29452-29453 | Ep_Exp | Generated Energy          | 0-999999999 | kWh      | Dword     | R/W             |
| 730EH-730FH   | 29454-29455 | Eq_Imp | Consumed Reactive Energy  | 0-999999999 | kvarh    | Dword     | R/W             |
| 7310H-7311H   | 29456-29457 | Eq_Exp | Generated Reactive Energy | 0-999999999 | kvarh    | Dword     | R/W             |
| 7312H-7313H   | 29458-29459 | Es     | Apparent Energy           | 0-999999999 | kVAh     | Dword     | R/W             |
| <b>Valley</b>   |             |        |                           |             |          |           |                 |
| 7314H-7315H   | 29460-29461 | Ep_Imp | Consumed Energy           | 0-999999999 | kWh      | Dword     | R/W             |
| 7316H-7317H   | 29462-29463 | Ep_Exp | Exported Energy           | 0-999999999 | kWh      | Dword     | R/W             |
| 7318H-7319H   | 29464-29465 | Eq_Imp | Consumed Reactive Energy  | 0-999999999 | kvarh    | Dword     | R/W             |
| 731AH-731BH   | 29466-29467 | Eq_Exp | Generated Reactive Energy | 0-999999999 | kvarh    | Dword     | R/W             |
| 731CH-731DH   | 29468-29469 | Es     | Apparent Energy           | 0-999999999 | kVAh     | Dword     | R/W             |
| <b>Normal</b>   |             |        |                           |             |          |           |                 |
| 731EH-731FH   | 29470-29741 | Ep_Imp | Consumed Energy           | 0-999999999 | kWh      | Dword     | R/W             |

| Current Month Incremental TOU Energy: 03H Read, 10H Write |             |        |                           |             |          |           |                 |
|---|-------------|--------|---------------------------|-------------|----------|-----------|-----------------|
| Address(H)  | Address(D)  | Symbol | Parameter                 | Range       | Property | Data Type | Access Property |
| 7320H-7321H   | 29472-29473 | Ep_Exp | Generated Energy          | 0-999999999 | kWh      | Dword     | R/W             |
| 7322H-7323H   | 29474-29475 | Eq_Imp | Consumed Reactive Energy  | 0-999999999 | kvarh    | Dword     | R/W             |
| 7324H-7325H   | 29476-29477 | Eq_Exp | Generated Reactive Energy | 0-999999999 | kvarh    | Dword     | R/W             |
| 7326H-7327H   | 29478-29479 | Es     | Apparent Energy           | 0-999999999 | kVAh     | Dword     | R/W             |
| <b>Total</b>  |             |        |                           |             |          |           |                 |
| 7328H-7329H   | 29480-29481 | Ep_Imp | Consumed Energy           | 0-999999999 | kWh      | Dword     | R/W             |
| 732AH-732BH   | 29482-29483 | Ep_Exp | Exported Energy           | 0-999999999 | kWh      | Dword     | R/W             |
| 732CH-732DH   | 29484-29485 | Eq_Imp | Consumed Reactive Energy  | 0-999999999 | kvarh    | Dword     | R/W             |
| 732EH-732FH   | 29486-29487 | Eq_Exp | Generated Reactive Energy | 0-999999999 | kvarh    | Dword     | R/W             |
| 7330H-7331H   | 29488-29489 | Es     | Apparent Energy           | 0-999999999 | kVAh     | Dword     | R/W             |

**Prior Month Incremental TOU Energy**

Table 6-24

| Prior Month Incremental TOU Energy: 03H Read, 10H Write |             |        |                           |             |          |           |                 |
|---|-------------|--------|---------------------------|-------------|----------|-----------|-----------------|
| Address(H)  | Address(D)  | Symbol | Parameter                 | Range       | Property | Data Type | Access Property |
| <b>Sharp</b>  |             |        |                           |             |          |           |                 |
| 7332H-7333H   | 29490-29491 | Ep_Imp | Consumed Energy           | 0-999999999 | kWh      | Dword     | R/W             |
| 7334H-7335H   | 29492-29493 | Ep_Exp | Generated Energy          | 0-999999999 | kWh      | Dword     | R/W             |
| 7336H-7337H   | 29494-29495 | Eq_Imp | Consumed Reactive Energy  | 0-999999999 | kvarh    | Dword     | R/W             |
| 7338H-7339H   | 29496-29497 | Eq_Exp | Generated Reactive Energy | 0-999999999 | kvarh    | Dword     | R/W             |
| 733AH-733BH   | 29498-29499 | Es     | Apparent Energy           | 0-999999999 | kVAh     | Dword     | R/W             |
| <b>Peak</b>   |             |        |                           |             |          |           |                 |
| 733CH-733DH   | 29500-29501 | Ep_Imp | Consumed Energy           | 0-999999999 | kWh      | Dword     | R/W             |

## Acuvim II Series Power Meter

| Prior Month Incremental TOU Energy: 03H Read, 10H Write |             |        |                           |             |          |           |                 |
|---|-------------|--------|---------------------------|-------------|----------|-----------|-----------------|
| Address(H)  | Address(D)  | Symbol | Parameter                 | Range       | Property | Data Type | Access Property |
| 733EH-733FH   | 29502-29503 | Ep_Exp | Generated Energy          | 0-999999999 | kWh      | Dword     | R/W             |
| 7340H-7341H   | 29504-29505 | Eq_Imp | Consumed Reactive Energy  | 0-999999999 | kvarh    | Dword     | R/W             |
| 7342H-7343H   | 29506-29507 | Eq_Exp | Generated Reactive Energy | 0-999999999 | kvarh    | Dword     | R/W             |
| 7344H-7345H   | 29508-29509 | Es     | Apparent Energy           | 0-999999999 | kVAh     | Dword     | R/W             |
| <b>Valley</b>   |             |        |                           |             |          |           |                 |
| 7346H-7347H   | 29510-29511 | Ep_Imp | Consumed Energy           | 0-999999999 | kWh      | Dword     | R/W             |
| 7348H-7349H   | 29512-29513 | Ep_Exp | Generated Energy          | 0-999999999 | kWh      | Dword     | R/W             |
| 734AH-734BH   | 29514-29515 | Eq_Imp | Consumed Reactive Energy  | 0-999999999 | kvarh    | Dword     | R/W             |
| 734CH-734DH   | 29516-29517 | Eq_Exp | Generated Reactive Energy | 0-999999999 | kvarh    | Dword     | R/W             |
| 734EH-734FH   | 29518-29519 | Es     | Apparent Energy           | 0-999999999 | kVA      | Dword     | R/W             |
| <b>Normal</b>   |             |        |                           |             |          |           |                 |
| 7350H-7351H   | 29520-29521 | Ep_Imp | Consumed Energy           | 0-999999999 | kWh      | Dword     | R/W             |
| 7352H-7353H   | 29522-29523 | Ep_Exp | Generated Energy          | 0-999999999 | kWh      | Dword     | R/W             |
| 7354H-7355H   | 29524-29525 | Eq_Imp | Consumed Reactive Energy  | 0-999999999 | kvarh    | Dword     | R/W             |
| 7356H-7357H   | 29526-29527 | Eq_Exp | Generated Reactive Energy | 0-999999999 | kvarh    | Dword     | R/W             |
| 7358H-7359H   | 29528-29529 | Es     | Apparent Energy           | 0-999999999 | kVAh     | Dword     | R/W             |
| <b>Total</b>  |             |        |                           |             |          |           |                 |
| 735AH-735BH   | 29530-29531 | Ep_Imp | Consumed Energy           | 0-999999999 | kWh      | Dword     | R/W             |
| 735CH-735DH   | 29532-29533 | Ep_Exp | Generated Energy          | 0-999999999 | kWh      | Dword     | R/W             |
| 735EH-735FH   | 29534-29535 | Eq_Imp | Consumed Reactive Energy  | 0-999999999 | kvarh    | Dword     | R/W             |
| 7360H-7361H   | 29536-29537 | Eq_Exp | Generated Reactive Energy | 0-999999999 | kvarh    | Dword     | R/W             |
| 7363H-7363H   | 29538-29539 | Es     | Apparent Energy           | 0-999999999 | kVAh     | Dword     | R/W             |

## Current Month Maximum Demand TOU

Table 6-25

| Current Month Maximum Demand TOU Energy: 03H Read, 10H Write |                 |        |            |                             |             |           |                 |
|--|-----------------|--------|------------|-----------------------------|-------------|-----------|-----------------|
| Address(H)   | Address(D)      | Symbol | Parameter  | Relationship                | Range       | Data Type | Access Property |
| Sharp  |                 |        |            |                             |             |           |                 |
| 7500H  | 29952           | Ep_Imp | Max Demand | Rx/10                       | 32768~32767 | Int       | R               |
| 7501H-7503H  | 29956           |        | Timestamp  | YY/MM;<br>DD/HH;<br>Min/Sec |             |           |                 |
| 7504H  | 29956           | Ep_Exp | Max Demand | Rx/10                       | 32768~32767 | Int       | R               |
| 7505H-7507H  | 29957-<br>29959 |        | Timestamp  | YY/MM;<br>DD/HH;<br>Min/Sec |             |           |                 |
| 7508H  | 29960           | Eq_Imp | Max Demand | Rx/10                       | 32768~32767 | Int       | R               |
| 7509H-750BH  | 29961-<br>29963 |        | Timestamp  | YY/MM;<br>DD/HH;<br>Min/Sec |             |           |                 |
| 750CH  | 29964           | Eq_Exp | Max Demand | Rx/10                       | 32768~32767 | Int       | R               |
| 750DH-750FH  | 29965-<br>29967 |        | Timestamp  | YY/MM;<br>DD/HH;<br>Min/Sec |             |           |                 |
| 7510H  | 29968           | Es     | Max Demand | Rx/10                       | 32768~32767 | Int       | R               |
| 7511H-7513H  | 29969-<br>29971 |        | Timestamp  | YY/MM;<br>DD/HH;<br>Min/Sec |             |           |                 |
| 7514H  | 29972           | Ia     | Max Demand | $Rx*(CT1/CT2)/1000$         | 32768~32767 | Int       | R               |
| 7515H-7517H  | 29973-<br>29975 |        | Timestamp  | YY/MM;<br>DD/HH;<br>Min/Sec |             |           |                 |
| 7518H  | 29976           | Ib     | Max Demand | $Rx*(CT1/CT2)/1000$         | 32768~32767 | Int       | R               |
| 7519H-751BH  | 29977-<br>29979 |        | Timestamp  | YY/MM;<br>DD/HH;<br>Min/Sec |             |           |                 |
| 751CH  | 29980           | Ic     | Max Demand | $Rx*(CT1/CT2)/1000$         | 32768~32767 | Int       | R               |

## Acuvim II Series Power Meter

| Current Month Maximum Demand TOU Energy: 03H Read, 10H Write |             |        |            |                             |             |           |                 |
|--|-------------|--------|------------|-----------------------------|-------------|-----------|-----------------|
| Address(H)   | Address(D)  | Symbol | Parameter  | Relationship                | Range       | Data Type | Access Property |
| 751DH-751FH  | 29981-29983 |        | Timestamp  | YY/MM;<br>DD/HH;<br>Min/Sec |             |           |                 |
| <b>Peak</b>  |             |        |            |                             |             |           |                 |
| 7520H  | 29984       | Ep_Imp | Max Demand | Rx/10                       | 32768~32767 | Int       | R               |
| 7521H-7523H  | 29985-29987 |        | Timestamp  | YY/MM;<br>DD/HH;<br>Min/Sec |             |           |                 |
| 7524H  | 29988       | Ep_Exp | Max Demand | Rx/10                       | 32768~32767 | Int       | R               |
| 7525H-7527H  | 29989-29991 |        | Timestamp  | YY/MM;<br>DD/HH;<br>Min/Sec |             |           |                 |
| 7528H  | 29992       | Eq_Imp | Max Demand | Rx/10                       | 32768~32767 | Int       | R               |
| 7529H-752BH  | 29993-29995 |        | Timestamp  | YY/MM;<br>DD/HH;<br>Min/Sec |             |           |                 |
| 752CH  | 29996       | Eq_Exp | Max Demand | Rx/10                       | 32768~32767 | Int       | R               |
| 752DH-752FH  | 29997-29999 |        | Timestamp  | YY/MM;<br>DD/HH;<br>Min/Sec |             |           |                 |
| 7530H  | 30000       | Es     | Max Demand | Rx/10                       | 32768~32767 | Int       | R               |
| 7531H-7533H  | 30001-30003 |        | Timestamp  | YY/MM;<br>DD/HH;<br>Min/Sec |             |           |                 |
| 7534H  | 30004       | Ia     | Max Demand | $Rx*(CT1/CT2)/1000$         | 32768~32767 | Int       | R               |
| 7535H-7537H  | 30005-30007 |        | Timestamp  | YY/MM;<br>DD/HH;<br>Min/Sec |             |           |                 |
| 7538H  | 30008       | Ib     | Max Demand | $Rx*(CT1/CT2)/1000$         | 32768~32767 | Int       | R               |
| 7539H-753BH  | 30009-30011 |        | Timestamp  | YY/MM;<br>DD/HH;<br>Min/Sec |             |           |                 |
| 753CH  | 30012       | Ic     | Max Demand | $Rx*(CT1/CT2)/1000$         | 32768~32767 | Int       | R               |

| Current Month Maximum Demand TOU Energy: 03H Read, 10H Write |             |        |            |                             |             |           |                 |
|--|-------------|--------|------------|-----------------------------|-------------|-----------|-----------------|
| Address(H)   | Address(D)  | Symbol | Parameter  | Relationship                | Range       | Data Type | Access Property |
| 753DH-753FH  | 30013-30015 |        | Timestamp  | YY/MM;<br>DD/HH;<br>Min/Sec |             |           |                 |
| <b>Valley</b>  |             |        |            |                             |             |           |                 |
| 7540H  | 30016       | Ep_Imp | Max Demand | Rx/10                       | 32768~32767 | Int       | R               |
| 7541H-7543H  | 30017-30019 |        | Timestamp  | YY/MM;<br>DD/HH;<br>Min/Sec |             |           |                 |
| 7544H  | 30020       | Ep_Exp | Max Demand | Rx/10                       | 32768~32767 | Int       | R               |
| 7545H-7547H  | 30021-30023 |        | Timestamp  | YY/MM;<br>DD/HH;<br>Min/Sec |             |           |                 |
| 7548H  | 30024       | Eq_Imp | Max Demand | Rx/10                       | 32768~32767 | Int       | R               |
| 7549H-754BH  | 30025-30026 |        | Timestamp  | YY/MM;<br>DD/HH;<br>Min/Sec |             |           |                 |
| 754CH  | 30027       | Eq_Exp | Max Demand | Rx/10                       | 32768~32767 | Int       | R               |
| 754DH-754FH  | 30028-30031 |        | Timestamp  | YY/MM;<br>DD/HH;<br>Min/Sec |             |           |                 |
| 7550H  | 30032       | Es     | Max Demand | Rx/10                       | 32768~32767 | Int       | R               |
| 7551H-7553H  | 30033-30035 |        | Timestamp  | YY/MM;<br>DD/HH;<br>Min/Sec |             |           |                 |
| 7554H  | 30036       | Ia     | Max Demand | $Rx*(CT1/CT2)/1000$         | 32768~32767 | Int       | R               |
| 7555H-7557H  | 30037-30039 |        | Timestamp  | YY/MM;<br>DD/HH;<br>Min/Sec |             |           |                 |
| 7558H  | 30040       | Ib     | Max Demand | $Rx*(CT1/CT2)/1000$         | 32768~32767 | Int       | R               |
| 7559H-755BH  | 30041-30043 |        | Timestamp  | YY/MM;<br>DD/HH;<br>Min/Sec |             |           |                 |
| 755CH  | 30044       | Ic     | Max Demand | $Rx*(CT1/CT2)/1000$         | 32768~32767 | Int       | R               |

## Acuvim II Series Power Meter

| Current Month Maximum Demand TOU Energy: 03H Read, 10H Write |             |        |            |                                |             |           |                 |
|--|-------------|--------|------------|--------------------------------|-------------|-----------|-----------------|
| Address(H)   | Address(D)  | Symbol | Parameter  | Relationship                   | Range       | Data Type | Access Property |
| 755DH-755FH  | 30045-30047 |        | Timestamp  | YY/MM;<br>DD/HH;<br>Min/Sec    |             |           |                 |
| <b>Normal</b>  |             |        |            |                                |             |           |                 |
| 7560H  | 30048       | Ep_Imp | Max Demand | Rx/10                          | 32768~32767 | Int       | R               |
| 7561H-7563H  | 30049-30051 |        | Timestamp  | YY/MM;<br>DD/HH;<br>Min/Sec    |             |           |                 |
| 7564H  | 30052       | Ep_Exp | Max Demand | Rx/10                          | 32768~32767 | Int       | R               |
| 7565H-7567H  | 30053-30055 |        | Timestamp  | YY/MM;<br>DD/HH;<br>Min/Sec    |             |           |                 |
| 7568H  | 30056       | Eq_Imp | Max Demand | Rx/10                          | 32768~32767 | Int       | R               |
| 7569H-756BH  | 30057-30059 |        | Timestamp  | YY/MM;<br>DD/HH;<br>Min/Sec    |             |           |                 |
| 756CH  | 30060       | Eq_Exp | Max Demand | Rx/10                          | 32768~32767 | Int       | R               |
| 756DH-756FH  | 30061-30063 |        | Timestamp  | YY/MM;<br>DD/HH;<br>Min/Sec    |             |           |                 |
| 7570H  | 30064       | Es     | Max Demand | Rx/10                          | 32768~32767 | Int       | R               |
| 7571H-7573H  | 30065-30067 |        | Timestamp  | YY/MM;<br>DD/HH;<br>Min/Sec    |             |           |                 |
| 7574H  | 30068       | Ia     | Max Demand | $Rx \times (CT1 / CT2) / 1000$ | 32768~32767 | Int       | R               |
| 7575H-7577H  | 30069-30071 |        | Timestamp  | YY/MM;<br>DD/HH;<br>Min/Sec    |             |           |                 |
| 7578H  | 30072       | Ib     | Max Demand | $Rx \times (CT1 / CT2) / 1000$ | 32768~32767 | Int       | R               |
| 7579H-757BH  | 30073-30075 |        | Timestamp  | YY/MM;<br>DD/HH;<br>Min/Sec    |             |           |                 |
| 757CH  | 30076       | Ic     | Max Demand | $Rx \times (CT1 / CT2) / 1000$ | 32768~32767 | Int       | R               |

| Current Month Maximum Demand TOU Energy: 03H Read, 10H Write |             |        |            |                                |             |           |                 |
|--|-------------|--------|------------|--------------------------------|-------------|-----------|-----------------|
| Address(H)   | Address(D)  | Symbol | Parameter  | Relationship                   | Range       | Data Type | Access Property |
| 757DH-757FH  | 30077-30079 |        | Timestamp  | YY/MM;<br>DD/HH;<br>Min/Sec    |             |           |                 |
| <b>Total</b>   |             |        |            |                                |             |           |                 |
| 7580H  | 30080       | Ep_Imp | Max Demand | Rx/10                          | 32768~32767 | Int       | R               |
| 7581H-7583H  | 30081-30083 |        | Timestamp  | YY/MM;<br>DD/HH;<br>Min/Sec    |             |           |                 |
| 7584H  | 30084       | Ep_Exp | Max Demand | Rx/10                          | 32768~32767 | Int       | R               |
| 7585H-7587H  | 30085-30087 |        | Timestamp  | YY/MM;<br>DD/HH;<br>Min/Sec    |             |           |                 |
| 7588H  | 30088       | Eq_Imp | Max Demand | Rx/10                          | 32768~32767 | Int       | R               |
| 7589H-758BH  | 30089-30091 |        | Timestamp  | YY/MM;<br>DD/HH;<br>Min/Sec    |             |           |                 |
| 758CH  | 30092       | Eq_Exp | Max Demand | Rx/10                          | 32768~32767 | Int       | R               |
| 758DH-758FH  | 30093-30095 |        | Timestamp  | YY/MM;<br>DD/HH;<br>Min/Sec    |             |           |                 |
| 7590H  | 30096       | Es     | Max Demand | Rx/10                          | 32768~32767 | Int       | R               |
| 7591H-7593H  | 30097-30099 |        | Timestamp  | YY/MM;<br>DD/HH;<br>Min/Sec    |             |           |                 |
| 7594H  | 30100       | Ia     | Max Demand | $Rx \times (CT1 / CT2) / 1000$ | 32768~32767 | Int       | R               |
| 7595H-7597H  | 30101-30103 |        | Timestamp  | YY/MM;<br>DD/HH;<br>Min/Sec    |             |           |                 |
| 7598H  | 30104       | Ib     | Max Demand | $Rx \times (CT1 / CT2) / 1000$ | 32768~32767 | Int       | R               |
| 7599H-759BH  | 30105-30107 |        | Timestamp  | YY/MM;<br>DD/HH;<br>Min/Sec    |             |           |                 |
| 759CH  | 30108       | Ic     | Max Demand | $Rx \times (CT1 / CT2) / 1000$ | 32768~32767 | Int       | R               |

## Acuvim II Series Power Meter

| Current Month Maximum Demand TOU Energy: 03H Read, 10H Write |             |        |           |                             |       |           |                 |
|--|-------------|--------|-----------|-----------------------------|-------|-----------|-----------------|
| Address(H)   | Address(D)  | Symbol | Parameter | Relationship                | Range | Data Type | Access Property |
| 759DH-759FH  | 30109-30111 |        | Timestamp | YY/MM;<br>DD/HH;<br>Min/Sec |       |           |                 |

### Prior Month Maximum Demand

Table 6-26

| Previous Month Maximum Demand TOU Energy: 03H, 10H Write |             |        |            |                             |             |           |                 |
|--|-------------|--------|------------|-----------------------------|-------------|-----------|-----------------|
| Address(H)   | Address(D)  | Symbol | Parameter  | Relationship                | Range       | Data Type | Access Property |
| <b>Sharp</b>   |             |        |            |                             |             |           |                 |
| 7600H  | 30208       | Ep_Imp | Max Demand | Rx/10                       | 32768~32767 | Int       | R               |
| 7601H-7603H  | 30209-30211 |        | Timestamp  | YY/MM;<br>DD/HH;<br>Min/Sec |             |           |                 |
| 7604H  | 30212       | Ep_Exp | Max Demand | Rx/10                       | 32768~32767 | Int       | R               |
| 7605H-7607H  | 30213-30215 |        | Timestamp  | YY/MM;<br>DD/HH;<br>Min/Sec |             |           |                 |
| 7608H  | 30216       | Eq_Imp | Max Demand | Rx/10                       | 32768~32767 | Int       | R               |
| 7609H-760BH  | 30217-30219 |        | Timestamp  | YY/MM;<br>DD/HH;<br>Min/Sec |             |           |                 |
| 760CH  | 30220       | Ep_Exp | Max Demand | Rx/10                       | 32768~32767 | Int       | R               |
| 760DH-760FH  | 30221-30223 |        | Timestamp  | YY/MM;<br>DD/HH;<br>Min/Sec |             |           |                 |
| 7610H  | 30224       | Es     | Max Demand | Rx/10                       | 32768~32767 | Int       | R               |
| 7611H-7613H  | 30225-30227 |        | Timestamp  | YY/MM;<br>DD/HH;<br>Min/Sec |             |           |                 |
| 7614H  | 30228       | Ia     | Max Demand | Rx*(CT1/<br>CT2)/1000       | 32768~32767 | Int       | R               |
| 7615H-7617H  | 30229-30231 |        | Timestamp  | YY/MM;<br>DD/HH;<br>Min/Sec |             |           |                 |

| Previous Month Maximum Demand TOU Energy: 03H, 10H Write |             |        |            |                             |             |           |                 |
|--|-------------|--------|------------|-----------------------------|-------------|-----------|-----------------|
| Address(H)   | Address(D)  | Symbol | Parameter  | Relationship                | Range       | Data Type | Access Property |
| 7618H  | 30232       | lb     | Max Demand | Rx*(CT1/CT2)/1000           | 32768~32767 | Int       | R               |
| 7619H-761BH  | 30233-30235 |        | Timestamp  | YY/MM;<br>DD/HH;<br>Min/Sec |             |           |                 |
| 761CH  | 30236       | lc     | Max Demand | Rx*(CT1/CT2)/1000           | 32768~32767 | Int       | R               |
| 761DH-761FH  | 30237-30239 |        | Timestamp  | YY/MM;<br>DD/HH;<br>Min/Sec |             |           |                 |
| <b>Peak</b>  |             |        |            |                             |             |           |                 |
| 7620H  | 30240       | Ep_Imp | Max Demand | Rx/10                       | 32768~32767 | Int       | R               |
| 7621H-7623H  | 30241-30243 |        | Timestamp  | YY/MM;<br>DD/HH;<br>Min/Sec |             |           |                 |
| 7624H  | 30244       | Ep_Exp | Max Demand | Rx/10                       | 32768~32767 | Int       | R               |
| 7625H-7627H  | 30245-30247 |        | Timestamp  | YY/MM;<br>DD/HH;<br>Min/Sec |             |           |                 |
| 7628H  | 30248       | Eq_Imp | Max Demand | Rx/10                       | 32768~32767 | Int       | R               |
| 7629H-762BH  | 30249-30251 |        | Timestamp  | YY/MM;<br>DD/HH;<br>Min/Sec |             |           |                 |
| 762CH  | 30252       | Eq_Exp | Max Demand | Rx/10                       | 32768~32767 | Int       | R               |
| 762DH-762FH  | 30253-30255 |        | Timestamp  | YY/MM;<br>DD/HH;<br>Min/Sec |             |           |                 |
| 7630H  | 30256       | Es     | Max Demand | Rx/10                       | 32768~32767 | Int       | R               |
| 7631H-7633H  | 30257-30259 |        | Timestamp  | YY/MM;<br>DD/HH;<br>Min/Sec |             |           |                 |
| 7634H  | 30260       | la     | Max Demand | Rx*(CT1/CT2)/1000           | 32768~32767 | Int       | R               |
| 7635H-7637H  | 30261-30263 |        | Timestamp  | YY/MM;<br>DD/HH;<br>Min/Sec |             |           |                 |

## Acuvim II Series Power Meter

| Previous Month Maximum Demand TOU Energy: 03H, 10H Write |             |        |            |                             |             |           |                 |
|--|-------------|--------|------------|-----------------------------|-------------|-----------|-----------------|
| Address(H)   | Address(D)  | Symbol | Parameter  | Relationship                | Range       | Data Type | Access Property |
| 7638H  | 30264       | lb     | Max Demand | Rx*(CT1/CT2)/1000           | 32768~32767 | Int       | R               |
| 7639H-763BH  | 30265-30267 |        | Timestamp  | YY/MM;<br>DD/HH;<br>Min/Sec |             |           |                 |
| 763CH  | 30268       | lc     | Max Demand | Rx*(CT1/CT2)/1000           | 32768~32767 | Int       | R               |
| 763DH-763FH  | 30269-30271 |        | Timestamp  | YY/MM;<br>DD/HH;<br>Min/Sec |             |           |                 |
| <b>Valley</b>  |             |        |            |                             |             |           |                 |
| 7640H  | 30272       | Ep_Imp | Max Demand | Rx/10                       | 32768~32767 | Int       | R               |
| 7641H-7643H  | 30273-30275 |        | Timestamp  | YY/MM;<br>DD/HH;<br>Min/Sec |             |           |                 |
| 7644H  | 30276       | Ep_Exp | Max Demand | Rx/10                       | 32768~32767 | Int       | R               |
| 7645H-7647H  | 30277-30279 |        | Timestamp  | YY/MM;<br>DD/HH;<br>Min/Sec |             |           |                 |
| 7648H  | 30280       | Eq_Imp | Max Demand | Rx/10                       | 32768~32767 | Int       | R               |
| 7649H-764BH  | 30281-30283 |        | Timestamp  | YY/MM;<br>DD/HH;<br>Min/Sec |             |           |                 |
| 764CH  | 30284       | Eq_Exp | Max Demand | Rx/10                       | 32768~32767 | Int       | R               |
| 764DH-764FH  | 30285-30287 |        | Timestamp  | YY/MM;<br>DD/HH;<br>Min/Sec |             |           |                 |
| 7650H  | 30288       | Es     | Max Demand | Rx/10                       | 32768~32767 | Int       | R               |
| 7651H-7653H  | 30289-30291 |        | Timestamp  | YY/MM;<br>DD/HH;<br>Min/Sec |             |           |                 |
| 7654H  | 30292       | la     | Max Demand | Rx*(CT1/CT2)/1000           | 32768~32767 | Int       | R               |
| 7655H-7657H  | 30293-30295 |        | Timestamp  | YY/MM;<br>DD/HH;<br>Min/Sec |             |           |                 |

| Previous Month Maximum Demand TOU Energy: 03H, 10H Write |                 |        |            |                             |             |           |                 |
|--|-----------------|--------|------------|-----------------------------|-------------|-----------|-----------------|
| Address(H)   | Address(D)      | Symbol | Parameter  | Relationship                | Range       | Data Type | Access Property |
| 7658H  | 30296           | lb     | Max Demand | Rx*(CT1/<br>CT2)/1000       | 32768~32767 | Int       | R               |
| 7659H-765BH  | 30297-<br>30299 |        | Timestamp  | YY/MM;<br>DD/HH;<br>Min/Sec |             |           |                 |
| 765CH  | 30300           | lc     | Max Demand | Rx*(CT1/<br>CT2)/1000       | 32768~32767 | Int       | R               |
| 765DH-765FH  | 30301-<br>30303 |        | Timestamp  | YY/MM;<br>DD/HH;<br>Min/Sec |             |           |                 |
| <b>Normal</b>  |                 |        |            |                             |             |           |                 |
| 7660H  | 30304           | Ep_Imp | Max Demand | Rx/10                       | 32768~32767 | Int       | R               |
| 7661H-7663H  | 30305-<br>30307 |        | Timestamp  | YY/MM;<br>DD/HH;<br>Min/Sec |             |           |                 |
| 7664H  | 30308           | Ep_Exp | Max Demand | Rx/10                       | 32768~32767 | Int       | R               |
| 7665H-7667H  | 30309-<br>30311 |        | Timestamp  | YY/MM;<br>DD/HH;<br>Min/Sec |             |           |                 |
| 7668H  | 30312           | Eq_Imp | Max Demand | Rx/10                       | 32768~32767 | Int       | R               |
| 7669H-766BH  | 30313-<br>30315 |        | Timestamp  | YY/MM;<br>DD/HH;<br>Min/Sec |             |           |                 |
| 766CH  | 30316           | Eq_Exp | Max Demand | Rx/10                       | 32768~32767 | Int       | R               |
| 766DH-766FH  | 30317-<br>30319 |        | Timestamp  | YY/MM;<br>DD/HH;<br>Min/Sec |             |           |                 |
| 7670H  | 30320           | Es     | Max Demand | Rx/10                       | 32768~32767 | Int       | R               |
| 7671H-7673H  | 30321-<br>30323 |        | Timestamp  | YY/MM;<br>DD/HH;<br>Min/Sec |             |           |                 |
| 7674H  | 30324           | la     | Max Demand | Rx*(CT1/<br>CT2)/1000       | 32768~32767 | Int       | R               |
| 7675H-7677H  | 30325-<br>30327 |        | Timestamp  | YY/MM;<br>DD/HH;<br>Min/Sec |             |           |                 |

## Acuvim II Series Power Meter

| Previous Month Maximum Demand TOU Energy: 03H, 10H Write |             |        |            |                             |             |           |                 |
|--|-------------|--------|------------|-----------------------------|-------------|-----------|-----------------|
| Address(H)   | Address(D)  | Symbol | Parameter  | Relationship                | Range       | Data Type | Access Property |
| 7678H  | 30328       | lb     | Max Demand | Rx*(CT1/CT2)/1000           | 32768~32767 | Int       | R               |
| 7679H-767BH  | 30329-30331 |        | Timestamp  | YY/MM;<br>DD/HH;<br>Min/Sec |             |           |                 |
| 767CH  | 30332       | lc     | Max Demand | Rx*(CT1/CT2)/1000           | 32768~32767 | Int       | R               |
| 767DH-767FH  | 30333-30334 |        | Timestamp  | YY/MM;<br>DD/HH;<br>Min/Sec |             |           |                 |
| <b>Total</b>   |             |        |            |                             |             |           |                 |
| 7680H  | 30336       | Ep_Imp | Max Demand | Rx/10                       | 32768~32767 | Int       | R               |
| 7681H-7683H  | 30337-30339 |        | Timestamp  | YY/MM;<br>DD/HH;<br>Min/Sec |             |           |                 |
| 7684H  | 30340       | Ep_Exp | Max Demand | Rx/10                       | 32768~32767 | Int       | R               |
| 7685H-7687H  | 30341-30343 |        | Timestamp  | YY/MM;<br>DD/HH;<br>Min/Sec |             |           |                 |
| 7688H  | 30344       | Eq_Imp | Max Demand | Rx/10                       | 32768~32767 | Int       | R               |
| 7689H-768BH  | 30345-30347 |        | Timestamp  | YY/MM;<br>DD/HH;<br>Min/Sec |             |           |                 |
| 768CH  | 30348       | Eq_Exp | Max Demand | Rx/10                       | 32768~32767 | Int       | R               |
| 768DH-768FH  | 30349-30351 |        | Timestamp  | YY/MM;<br>DD/HH;<br>Min/Sec |             |           |                 |
| 7690H  | 30352       | Es     | Max Demand | Rx/10                       | 32768~32767 | Int       | R               |
| 7691H-7693H  | 30353-30355 |        | Timestamp  | YY/MM;<br>DD/HH;<br>Min/Sec |             |           |                 |
| 7694H  | 30356       | la     | Max Demand | Rx*(CT1/CT2)/1000           | 32768~32767 | Int       | R               |
| 7695H-7697H  | 30357-30359 |        | Timestamp  | YY/MM;<br>DD/HH;<br>Min/Sec |             |           |                 |

| Previous Month Maximum Demand TOU Energy: 03H, 10H Write |             |        |            |                             |             |           |                 |
|--|-------------|--------|------------|-----------------------------|-------------|-----------|-----------------|
| Address(H)   | Address(D)  | Symbol | Parameter  | Relationship                | Range       | Data Type | Access Property |
| 7698H  | 30360       | lb     | Max Demand | Rx*(CT1/CT2)/1000           | 32768~32767 | Int       | R               |
| 7699H-769BH  | 30361-30363 |        | Timestamp  | YY/MM;<br>DD/HH;<br>Min/Sec |             |           |                 |
| 769CH  | 30364       | lc     | Max Demand | Rx*(CT1/CT2)/1000           | 32768~32767 | Int       | R               |
| 769DH-769FH  | 30365-30366 |        | Timestamp  | YY/MM;<br>DD/HH;<br>Min/Sec |             |           |                 |

### 6.3.10 Power Quality Parameters

THD, Harmonics, odd HD, Crest Factor, THFF, K factor, etc. are all stored here where the data type is "Word."

**NOTE:** Voltage parameters refer to line voltage when it is set to "2LL/3LL" and phase voltage for others.

#### THD Parameters

Table 6-27

| Power Quality: 03H Read |            |             |              |          |       |           |                 |
|-------------------------|------------|-------------|--------------|----------|-------|-----------|-----------------|
| Address(H)              | Address(D) | Parameter   | Relationship | Property | Range | Data Type | Access Property |
| 405AH                   | 16474      | THD_V1(V12) | THD=Rx/100   | %        | ≥0    | Word      | R               |
| 405BH                   | 16475      | THD_V2(V31) | THD=Rx/100   | %        | ≥0    | Word      | R               |
| 405CH                   | 16476      | THD_V3(V23) | THD=Rx/100   | %        | ≥0    | Word      | R               |
| 405DH                   | 16477      | THD_avg     | THD=Rx/100   | %        | ≥0    | Word      | R               |
| 405EH                   | 16478      | THD_I1      | THD=Rx/100   | %        | ≥0    | Word      | R               |
| 405FH                   | 16479      | THD_I2      | THD=Rx/100   | %        | ≥0    | Word      | R               |
| 4060H                   | 16480      | THD_I3      | THD=Rx/100   | %        | ≥0    | Word      | R               |
| 4061H                   | 16481      | THD_Iavg    | THD=Rx/100   | %        | ≥0    | Word      | R               |

Voltage V1 (V12) Harmonics

Table 6-28

| Voltage Harmonics, Even & Odd Harmonics, Crest Factor: 03H Read |            |                       |              |          |       |           |                 |
|---|------------|-----------------------|--------------|----------|-------|-----------|-----------------|
| Address(H)  | Address(D) | Parameter             | Relationship | Property | Range | Data Type | Access Property |
| 4062H   | 16482      | V1(V12) 2nd Harmonic  | THD=Rx/100   | %        | ≥0    | Word      | R               |
| 4063H   | 16483      | V1(V12) 3rd Harmonic  | THD=Rx/100   | %        | ≥0    | Word      | R               |
| 4064H   | 16484      | V1(V12) 4th Harmonic  | THD=Rx/100   | %        | ≥0    | Word      | R               |
| 4065H   | 16485      | V1(V12) 5th Harmonic  | THD=Rx/100   | %        | ≥0    | Word      | R               |
| 4066H   | 16486      | V1(V12) 6th Harmonic  | THD=Rx/100   | %        | ≥0    | Word      | R               |
| 4067H   | 16487      | V1(V12) 7th Harmonic  | THD=Rx/100   | %        | ≥0    | Word      | R               |
| 4068H   | 16488      | V1(V12) 8th Harmonic  | THD=Rx/100   | %        | ≥0    | Word      | R               |
| 4069H   | 16489      | V1(V12) 9th Harmonic  | THD=Rx/100   | %        | ≥0    | Word      | R               |
| 406AH   | 16490      | V1(V12) 10th Harmonic | THD=Rx/100   | %        | ≥0    | Word      | R               |
| 406BH   | 16491      | V1(V12) 11th Harmonic | THD=Rx/100   | %        | ≥0    | Word      | R               |
| 406CH   | 16492      | V1(V12) 12th Harmonic | THD=Rx/100   | %        | ≥0    | Word      | R               |
| 406DH   | 16493      | V1(V12) 13th Harmonic | THD=Rx/100   | %        | ≥0    | Word      | R               |
| 406EH   | 16494      | V1(V12) 14th Harmonic | THD=Rx/100   | %        | ≥0    | Word      | R               |
| 406FH   | 16495      | V1(V12) 15th Harmonic | THD=Rx/100   | %        | ≥0    | Word      | R               |
| 4070H   | 16496      | V1(V12) 16th Harmonic | THD=Rx/100   | %        | ≥0    | Word      | R               |
| 4071H   | 16497      | V1(V12) 17th Harmonic | THD=Rx/100   | %        | ≥0    | Word      | R               |
| 4072H   | 16498      | V1(V12) 18th Harmonic | THD=Rx/100   | %        | ≥0    | Word      | R               |
| 4073H   | 16499      | V1(V12) 19th Harmonic | THD=Rx/100   | %        | ≥0    | Word      | R               |
| 4074H   | 16500      | V1(V12) 20th Harmonic | THD=Rx/100   | %        | ≥0    | Word      | R               |
| 4075H   | 16501      | V1(V12) 21st Harmonic | THD=Rx/100   | %        | ≥0    | Word      | R               |

| Voltage Harmonics, Even & Odd Harmonics, Crest Factor: 03H Read |            |                       |              |          |       |           |                 |
|---|------------|-----------------------|--------------|----------|-------|-----------|-----------------|
| Address(H)  | Address(D) | Parameter             | Relationship | Property | Range | Data Type | Access Property |
| 4076H   | 16502      | V1(V12) 22nd Harmonic | THD=Rx/100   | %        | ≥0    | Word      | R               |
| 4077H   | 16503      | V1(V12) 23rd Harmonic | THD=Rx/100   | %        | ≥0    | Word      | R               |
| 4078H   | 16504      | V1(V12) 24th Harmonic | THD=Rx/100   | %        | ≥0    | Word      | R               |
| 4079H   | 16505      | V1(V12) 25th Harmonic | THD=Rx/100   | %        | ≥0    | Word      | R               |
| 407AH   | 16506      | V1(V12) 26th Harmonic | THD=Rx/100   | %        | ≥0    | Word      | R               |
| 407BH   | 16507      | V1(V12) 27th Harmonic | THD=Rx/100   | %        | ≥0    | Word      | R               |
| 407CH   | 16508      | V1(V12) 28th Harmonic | THD=Rx/100   | %        | ≥0    | Word      | R               |
| 407DH   | 16509      | V1(V12) 29th Harmonic | THD=Rx/100   | %        | ≥0    | Word      | R               |
| 407EH   | 16510      | V1(V12) 30th Harmonic | THD=Rx/100   | %        | ≥0    | Word      | R               |
| 407FH   | 16511      | V1(V12) 31st Harmonic | THD=Rx/100   | %        | ≥0    | Word      | R               |
| 4500H   | 17664      | V1(V12) 32nd Harmonic | THD=Rx/100   | %        | ≥0    | Word      | R               |
| 4501H   | 17665      | V1(V12) 33rd Harmonic | THD=Rx/100   | %        | ≥0    | Word      | R               |
| 4502H   | 17666      | V1(V12) 34th Harmonic | THD=Rx/100   | %        | ≥0    | Word      | R               |
| 4503H   | 17667      | V1(V12) 35th Harmonic | THD=Rx/100   | %        | ≥0    | Word      | R               |
| 4504H   | 17668      | V1(V12) 36th Harmonic | THD=Rx/100   | %        | ≥0    | Word      | R               |
| 4505H   | 17669      | V1(V12) 37th Harmonic | THD=Rx/100   | %        | ≥0    | Word      | R               |
| 4506H   | 17670      | V1(V12) 38th Harmonic | THD=Rx/100   | %        | ≥0    | Word      | R               |
| 4507H   | 17671      | V1(V12) 39th Harmonic | THD=Rx/100   | %        | ≥0    | Word      | R               |
| 4508H   | 17672      | V1(V12) 40th Harmonic | THD=Rx/100   | %        | ≥0    | Word      | R               |
| 4509H   | 17673      | V1(V12) 41st Harmonic | THD=Rx/100   | %        | ≥0    | Word      | R               |
| 450AH   | 17674      | V1(V12) 42nd Harmonic | THD=Rx/100   | %        | ≥0    | Word      | R               |
| 450BH   | 17675      | V1(V12) 43rd Harmonic | THD=Rx/100   | %        | ≥0    | Word      | R               |

## Acuvim II Series Power Meter

| Voltage Harmonics, Even & Odd Harmonics, Crest Factor: 03H Read |            |                       |              |          |       |           |                 |
|---|------------|-----------------------|--------------|----------|-------|-----------|-----------------|
| Address(H)  | Address(D) | Parameter             | Relationship | Property | Range | Data Type | Access Property |
| 450CH   | 17676      | V1(V12) 44th Harmonic | THD=Rx/100   | %        | ≥0    | Word      | R               |
| 450DH   | 17677      | V1(V12) 45th Harmonic | THD=Rx/100   | %        | ≥0    | Word      | R               |
| 450EH   | 17678      | V1(V12) 46th Harmonic | THD=Rx/100   | %        | ≥0    | Word      | R               |
| 450FH   | 17679      | V1(V12) 47th Harmonic | THD=Rx/100   | %        | ≥0    | Word      | R               |
| 4510H   | 17680      | V1(V12) 48th Harmonic | THD=Rx/100   | %        | ≥0    | Word      | R               |
| 4511H   | 17681      | V1(V12) 49th Harmonic | THD=Rx/100   | %        | ≥0    | Word      | R               |
| 4512H   | 17682      | V1(V12) 50th Harmonic | THD=Rx/100   | %        | ≥0    | Word      | R               |
| 4513H   | 17683      | V1(V12) 51st Harmonic | THD=Rx/100   | %        | ≥0    | Word      | R               |
| 4514H   | 17684      | V1(V12) 52nd Harmonic | THD=Rx/100   | %        | ≥0    | Word      | R               |
| 4515H   | 17685      | V1(V12) 53rd Harmonic | THD=Rx/100   | %        | ≥0    | Word      | R               |
| 4516H   | 17686      | V1(V12) 54th Harmonic | THD=Rx/100   | %        | ≥0    | Word      | R               |
| 4517H   | 17687      | V1(V12) 55th Harmonic | THD=Rx/100   | %        | ≥0    | Word      | R               |
| 4518H   | 17688      | V1(V12) 56th Harmonic | THD=Rx/100   | %        | ≥0    | Word      | R               |
| 4519H   | 17689      | V1(V12) 57th Harmonic | THD=Rx/100   | %        | ≥0    | Word      | R               |
| 451AH   | 17690      | V1(V12) 58th Harmonic | THD=Rx/100   | %        | ≥0    | Word      | R               |
| 451BH   | 17691      | V1(V12) 59th Harmonic | THD=Rx/100   | %        | ≥0    | Word      | R               |
| 451CH   | 17692      | V1(V12) 60th Harmonic | THD=Rx/100   | %        | ≥0    | Word      | R               |
| 451DH   | 17693      | V1(V12) 61st Harmonic | THD=Rx/100   | %        | ≥0    | Word      | R               |
| 451EH   | 17694      | V1(V12) 62nd Harmonic | THD=Rx/100   | %        | ≥0    | Word      | R               |
| 451FH   | 17695      | V1(V12) 63rd Harmonic | THD=Rx/100   | %        | ≥0    | Word      | R               |
| 4080H   | 16512      | Odd THD_V1(V12)       | THD=Rx/100   | %        | ≥0    | Word      | R               |
| 4081H   | 16513      | Even THD_V1(V12)      | THD=Rx/100   | %        | ≥0    | Word      | R               |

| Voltage Harmonics, Even & Odd Harmonics, Crest Factor: 03H Read |            |                      |                          |          |         |           |                 |
|---|------------|----------------------|--------------------------|----------|---------|-----------|-----------------|
| Address(H)  | Address(D) | Parameter            | Relationship             | Property | Range   | Data Type | Access Property |
| 4082H   | 16514      | Crest Factor V1(V12) | CF=R <sub>x</sub> /100   | %        | 0~65535 | Word      | R               |
| 4083H   | 16515      | THFF_V1(V12)         | THFF=R <sub>x</sub> /100 | %        | ≥0      | Word      | R               |

## Voltage V2(V31) Harmonics

Table 6-29

| Voltage Harmonics, Even & Odd Harmonics, Crest Factor: 03H Read |            |                       |                         |          |       |           |                 |
|---|------------|-----------------------|-------------------------|----------|-------|-----------|-----------------|
| Address(H)  | Address(D) | Parameter             | Relationship            | Property | Range | Data Type | Access Property |
| 4084H   | 16516      | V2(V31) 2nd Harmonic  | THD=R <sub>x</sub> /100 | %        | ≥0    | Word      | R               |
| 4085H   | 16517      | V2(V31) 3rd Harmonic  | THD=R <sub>x</sub> /100 | %        | ≥0    | Word      | R               |
| 4086H   | 16518      | V2(V31) 4th Harmonic  | THD=R <sub>x</sub> /100 | %        | ≥0    | Word      | R               |
| 4087H   | 16519      | V2(V31) 5th Harmonic  | THD=R <sub>x</sub> /100 | %        | ≥0    | Word      | R               |
| 4088H   | 16520      | V2(V31) 6th Harmonic  | THD=R <sub>x</sub> /100 | %        | ≥0    | Word      | R               |
| 4089H   | 16521      | V2(V31) 7th Harmonic  | THD=R <sub>x</sub> /100 | %        | ≥0    | Word      | R               |
| 408AH   | 16522      | V2(V31) 8th Harmonic  | THD=R <sub>x</sub> /100 | %        | ≥0    | Word      | R               |
| 408BH   | 16523      | V2(V31) 9th Harmonic  | THD=R <sub>x</sub> /100 | %        | ≥0    | Word      | R               |
| 408CH   | 16524      | V2(V31) 10th Harmonic | THD=R <sub>x</sub> /100 | %        | ≥0    | Word      | R               |
| 408DH   | 16525      | V2(V31) 11th Harmonic | THD=R <sub>x</sub> /100 | %        | ≥0    | Word      | R               |
| 408EH   | 16526      | V2(V31) 12th Harmonic | THD=R <sub>x</sub> /100 | %        | ≥0    | Word      | R               |
| 408FH   | 16527      | V2(V31) 13th Harmonic | THD=R <sub>x</sub> /100 | %        | ≥0    | Word      | R               |
| 4090H   | 16528      | V2(V31) 14th Harmonic | THD=R <sub>x</sub> /100 | %        | ≥0    | Word      | R               |
| 4091H   | 16529      | V2(V31) 15th Harmonic | THD=R <sub>x</sub> /100 | %        | ≥0    | Word      | R               |
| 4092H   | 16530      | V2(V31) 16th Harmonic | THD=R <sub>x</sub> /100 | %        | ≥0    | Word      | R               |
| 4093H   | 16531      | V2(V31) 17th Harmonic | THD=R <sub>x</sub> /100 | %        | ≥0    | Word      | R               |

## Acuvim II Series Power Meter

| Voltage Harmonics, Even & Odd Harmonics, Crest Factor: 03H Read |            |                       |              |          |       |           |                 |
|---|------------|-----------------------|--------------|----------|-------|-----------|-----------------|
| Address(H)  | Address(D) | Parameter             | Relationship | Property | Range | Data Type | Access Property |
| 4094H   | 16532      | V2(V31) 18th Harmonic | THD=Rx/100   | %        | ≥0    | Word      | R               |
| 4095H   | 16533      | V2(V31) 19th Harmonic | THD=Rx/100   | %        | ≥0    | Word      | R               |
| 4096H   | 16534      | V2(V31) 20th Harmonic | THD=Rx/100   | %        | ≥0    | Word      | R               |
| 4097H   | 16535      | V2(V31) 21th Harmonic | THD=Rx/100   | %        | ≥0    | Word      | R               |
| 4098H   | 16536      | V2(V31) 22th Harmonic | THD=Rx/100   | %        | ≥0    | Word      | R               |
| 4099H   | 16537      | V2(V31) 23rd Harmonic | THD=Rx/100   | %        | ≥0    | Word      | R               |
| 409AH   | 16538      | V2(V31) 24th Harmonic | THD=Rx/100   | %        | ≥0    | Word      | R               |
| 409BH   | 16539      | V2(V31) 25th Harmonic | THD=Rx/100   | %        | ≥0    | Word      | R               |
| 409CH   | 16540      | V2(V31) 26th Harmonic | THD=Rx/100   | %        | ≥0    | Word      | R               |
| 409DH   | 16541      | V2(V31) 27th Harmonic | THD=Rx/100   | %        | ≥0    | Word      | R               |
| 409EH   | 16542      | V2(V31) 28th Harmonic | THD=Rx/100   | %        | ≥0    | Word      | R               |
| 409FH   | 16543      | V2(V31) 29th Harmonic | THD=Rx/100   | %        | ≥0    | Word      | R               |
| 40A0H   | 16544      | V2(V31) 30th Harmonic | THD=Rx/100   | %        | ≥0    | Word      | R               |
| 40A1H   | 16545      | V2(V31) 31st Harmonic | THD=Rx/100   | %        | ≥0    | Word      | R               |
| 4520H   | 17696      | V2(V31) 32nd Harmonic | THD=Rx/100   | %        | ≥0    | Word      | R               |
| 4521H   | 17697      | V2(V31) 33rd Harmonic | THD=Rx/100   | %        | ≥0    | Word      | R               |
| 4522H   | 17698      | V2(V31) 34th Harmonic | THD=Rx/100   | %        | ≥0    | Word      | R               |
| 4523H   | 17699      | V2(V31) 35th Harmonic | THD=Rx/100   | %        | ≥0    | Word      | R               |
| 4524H   | 17700      | V2(V31) 36th Harmonic | THD=Rx/100   | %        | ≥0    | Word      | R               |
| 4525H   | 17701      | V2(V31) 37th Harmonic | THD=Rx/100   | %        | ≥0    | Word      | R               |
| 4526H   | 17702      | V2(V31) 38th Harmonic | THD=Rx/100   | %        | ≥0    | Word      | R               |
| 4527H   | 17703      | V2(V31) 39th Harmonic | THD=Rx/100   | %        | ≥0    | Word      | R               |

| Voltage Harmonics, Even & Odd Harmonics, Crest Factor: 03H Read |            |                       |              |          |       |           |                 |
|---|------------|-----------------------|--------------|----------|-------|-----------|-----------------|
| Address(H)  | Address(D) | Parameter             | Relationship | Property | Range | Data Type | Access Property |
| 4528H   | 17704      | V2(V31) 40th Harmonic | THD=Rx/100   | %        | ≥0    | Word      | R               |
| 4529H   | 17705      | V2(V31) 41st Harmonic | THD=Rx/100   | %        | ≥0    | Word      | R               |
| 452AH   | 17706      | V2(V31) 42nd Harmonic | THD=Rx/100   | %        | ≥0    | Word      | R               |
| 452BH   | 17707      | V2(V31) 43rd Harmonic | THD=Rx/100   | %        | ≥0    | Word      | R               |
| 452CH   | 17708      | V2(V31) 44th Harmonic | THD=Rx/100   | %        | ≥0    | Word      | R               |
| 425DH   | 17709      | V2(V31) 45th Harmonic | THD=Rx/100   | %        | ≥0    | Word      | R               |
| 452EH   | 17710      | V2(V31) 46th Harmonic | THD=Rx/100   | %        | ≥0    | Word      | R               |
| 452FH   | 17711      | V2(V31) 47th Harmonic | THD=Rx/100   | %        | ≥0    | Word      | R               |
| 4530H   | 17712      | V2(V31) 48th Harmonic | THD=Rx/100   | %        | ≥0    | Word      | R               |
| 4531H   | 17713      | V2(V31) 49th Harmonic | THD=Rx/100   | %        | ≥0    | Word      | R               |
| 4532H   | 17714      | V2(V31) 50th Harmonic | THD=Rx/100   | %        | ≥0    | Word      | R               |
| 4533H   | 17715      | V2(V31) 51st Harmonic | THD=Rx/100   | %        | ≥0    | Word      | R               |
| 4534H   | 17716      | V2(V31) 52nd Harmonic | THD=Rx/100   | %        | ≥0    | Word      | R               |
| 4535H   | 17717      | V2(V31) 53rd Harmonic | THD=Rx/100   | %        | ≥0    | Word      | R               |
| 4536H   | 17718      | V2(V31) 54th Harmonic | THD=Rx/100   | %        | ≥0    | Word      | R               |
| 4537H   | 17719      | V2(V31) 55th Harmonic | THD=Rx/100   | %        | ≥0    | Word      | R               |
| 4538H   | 17720      | V2(V31) 56th Harmonic | THD=Rx/100   | %        | ≥0    | Word      | R               |
| 4539H   | 17721      | V2(V31) 57th Harmonic | THD=Rx/100   | %        | ≥0    | Word      | R               |
| 453AH   | 17722      | V2(V31) 58th Harmonic | THD=Rx/100   | %        | ≥0    | Word      | R               |
| 453BH   | 17723      | V2(V31) 59th Harmonic | THD=Rx/100   | %        | ≥0    | Word      | R               |
| 453CH   | 17724      | V2(V31) 60th Harmonic | THD=Rx/100   | %        | ≥0    | Word      | R               |
| 453DH   | 17725      | V2(V31) 61st Harmonic | THD=Rx/100   | %        | ≥0    | Word      | R               |

## Acuvim II Series Power Meter

| Voltage Harmonics, Even & Odd Harmonics, Crest Factor: 03H Read |            |                       |              |          |       |           |                 |
|---|------------|-----------------------|--------------|----------|-------|-----------|-----------------|
| Address(H)  | Address(D) | Parameter             | Relationship | Property | Range | Data Type | Access Property |
| 453EH   | 17726      | V2(V31) 62nd Harmonic | THD=Rx/100   | %        | ≥0    | Word      | R               |
| 453FH   | 17727      | V2(V31) 63rd Harmonic | THD=Rx/100   | %        | ≥0    | Word      | R               |
| 40A2H   | 16546      | Odd THD_V2(V31)       | THD=Rx/100   | %        | ≥0    | Word      | R               |
| 40A3H   | 16547      | Even THD_V2(V31)      | THD=Rx/100   | %        | ≥0    | Word      | R               |
| 40A4H   | 16548      | Crest Factor V2(V31)  | THD=Rx/100   | %        | ≥0    | Word      | R               |
| 40A5H   | 16549      | THFF_V2(V31)          | THFF=Rx/100  | %        | ≥0    | Word      | R               |

### Voltage V3(V23) Harmonics

Table 6-30

| Voltage Harmonics, Even & Odd Harmonics, Crest Factor: 03H |            |                       |              |          |       |           |                 |
|--|------------|-----------------------|--------------|----------|-------|-----------|-----------------|
| Address(H)   | Address(D) | Parameter             | Relationship | Property | Range | Data Type | Access Property |
| 40A6H  | 16550      | V3(V23) 2nd Harmonic  | THD=Rx/100   | %        | ≥0    | Word      | R               |
| 40A7H  | 16551      | V3(V23) 3rd Harmonic  | THD= Rx/100  | %        | ≥0    | Word      | R               |
| 40A8H  | 16552      | V3(V23) 4th Harmonic  | THD=Rx/100   | %        | ≥0    | Word      | R               |
| 40A9H  | 16553      | V3(V23) 5th Harmonic  | THD=Rx/100   | %        | ≥0    | Word      | R               |
| 40AAH  | 16554      | V3(V23) 6th Harmonic  | THD=Rx/100   | %        | ≥0    | Word      | R               |
| 40ABH  | 16555      | V3(V23) 7th Harmonic  | THD=Rx/100   | %        | ≥0    | Word      | R               |
| 40ACH  | 16556      | V3(V23) 8th Harmonic  | THD=Rx/100   | %        | ≥0    | Word      | R               |
| 40ADH  | 16557      | V3(V23) 9th Harmonic  | THD=Rx/100   | %        | ≥0    | Word      | R               |
| 40AEH  | 16558      | V3(V23) 10th Harmonic | THD=Rx/100   | %        | ≥0    | Word      | R               |
| 40AFH  | 16559      | V3(V23) 11th Harmonic | THD=Rx/100   | %        | ≥0    | Word      | R               |
| 40B0H  | 16560      | V3(V23) 12th Harmonic | THD=Rx/100   | %        | ≥0    | Word      | R               |
| 40B1H  | 16561      | V3(V23) 13th Harmonic | THD=Rx/100   | %        | ≥0    | Word      | R               |
| 40B2H  | 16562      | V3(V23) 14th Harmonic | THD=Rx/100   | %        | ≥0    | Word      | R               |

| Voltage Harmonics, Even & Odd Harmonics, Crest Factor: 03H |            |                       |              |          |       |           |                 |
|--|------------|-----------------------|--------------|----------|-------|-----------|-----------------|
| Address(H)   | Address(D) | Parameter             | Relationship | Property | Range | Data Type | Access Property |
| 40B3H  | 16563      | V3(V23) 15th Harmonic | THD=Rx/100   | %        | ≥0    | Word      | R               |
| 40B4H  | 16564      | V3(V23) 16th Harmonic | THD=Rx/100   | %        | ≥0    | Word      | R               |
| 40B5H  | 16565      | V3(V23) 17th Harmonic | THD=Rx/100   | %        | ≥0    | Word      | R               |
| 40B6H  | 16566      | V3(V23) 18th Harmonic | THD=Rx/100   | %        | ≥0    | Word      | R               |
| 40B7H  | 16567      | V3(V23) 19th Harmonic | THD=Rx/100   | %        | ≥0    | Word      | R               |
| 40B8H  | 16568      | V3(V23) 20th Harmonic | THD=Rx/100   | %        | ≥0    | Word      | R               |
| 40B9H  | 16569      | V3(V23) 21st Harmonic | THD=Rx/100   | %        | ≥0    | Word      | R               |
| 40BAH  | 16570      | V3(V23) 22nd Harmonic | THD=Rx/100   | %        | ≥0    | Word      | R               |
| 40BBH  | 16571      | V3(V23) 23rd Harmonic | THD=Rx/100   | %        | ≥0    | Word      | R               |
| 40BCH  | 16572      | V3(V23) 24th Harmonic | THD=Rx/100   | %        | ≥0    | Word      | R               |
| 40BDH  | 16573      | V3(V23) 25th Harmonic | THD=Rx/100   | %        | ≥0    | Word      | R               |
| 40BEH  | 16574      | V3(V23) 26th Harmonic | THD=Rx/100   | %        | ≥0    | Word      | R               |
| 40BFH  | 16575      | V3(V23) 27th Harmonic | THD=Rx/100   | %        | ≥0    | Word      | R               |
| 40C0H  | 16576      | V3(V23) 28th Harmonic | THD=Rx/100   | %        | ≥0    | Word      | R               |
| 40C1H  | 16577      | V3(V23) 29th Harmonic | THD=Rx/100   | %        | ≥0    | Word      | R               |
| 40C2H  | 16578      | V3(V23) 30th Harmonic | THD=Rx/100   | %        | ≥0    | Word      | R               |
| 40C3H  | 16579      | V3(V23) 31st Harmonic | THD=Rx/100   | %        | ≥0    | Word      | R               |
| 4540H  | 17728      | V3(V23) 32nd Harmonic | THD=Rx/100   | %        | ≥0    | Word      | R               |
| 4541H  | 17729      | V3(V23) 33rd Harmonic | THD=Rx/100   | %        | ≥0    | Word      | R               |
| 4542H  | 17730      | V3(V23) 34th Harmonic | THD=Rx/100   | %        | ≥0    | Word      | R               |
| 4543H  | 17731      | V3(V23) 35th Harmonic | THD=Rx/100   | %        | ≥0    | Word      | R               |
| 4544H  | 17732      | V3(V23) 36th Harmonic | THD=Rx/100   | %        | ≥0    | Word      | R               |

## Acuvim II Series Power Meter

| Voltage Harmonics, Even & Odd Harmonics, Crest Factor: 03H |            |                       |              |          |       |           |                 |
|--|------------|-----------------------|--------------|----------|-------|-----------|-----------------|
| Address(H)   | Address(D) | Parameter             | Relationship | Property | Range | Data Type | Access Property |
| 4545H  | 17733      | V3(V23) 37th Harmonic | THD=Rx/100   | %        | ≥0    | Word      | R               |
| 4546H  | 17734      | V3(V23) 38th Harmonic | THD=Rx/100   | %        | ≥0    | Word      | R               |
| 4547H  | 17735      | V3(V23) 39th Harmonic | THD=Rx/100   | %        | ≥0    | Word      | R               |
| 4548H  | 17736      | V3(V23) 40th Harmonic | THD=Rx/100   | %        | ≥0    | Word      | R               |
| 4549H  | 17737      | V3(V23) 41st Harmonic | THD=Rx/100   | %        | ≥0    | Word      | R               |
| 454AH  | 17738      | V3(V23) 42nd Harmonic | THD=Rx/100   | %        | ≥0    | Word      | R               |
| 454BH  | 17739      | V3(V23) 43rd Harmonic | THD=Rx/100   | %        | ≥0    | Word      | R               |
| 454CH  | 17740      | V3(V23) 44th Harmonic | THD=Rx/100   | %        | ≥0    | Word      | R               |
| 454DH  | 17741      | V3(V23) 45th Harmonic | THD=Rx/100   | %        | ≥0    | Word      | R               |
| 454EH  | 17742      | V3(V23) 46th Harmonic | THD=Rx/100   | %        | ≥0    | Word      | R               |
| 454FH  | 17743      | V3(V23) 47th Harmonic | THD=Rx/100   | %        | ≥0    | Word      | R               |
| 4550H  | 17744      | V3(V23) 48th Harmonic | THD=Rx/100   | %        | ≥0    | Word      | R               |
| 4551H  | 17745      | V3(V23) 49th Harmonic | THD=Rx/100   | %        | ≥0    | Word      | R               |
| 4552H  | 17746      | V3(V23) 50th Harmonic | THD=Rx/100   | %        | ≥0    | Word      | R               |
| 4553H  | 17747      | V3(V23) 51st Harmonic | THD=Rx/100   | %        | ≥0    | Word      | R               |
| 4554H  | 17748      | V3(V23) 52nd Harmonic | THD=Rx/100   | %        | ≥0    | Word      | R               |
| 4555H  | 17749      | V3(V23) 53rd Harmonic | THD=Rx.100   | %        | ≥0    | Word      | R               |
| 4556H  | 17750      | V3(V23) 54th Harmonic | THD=Rx/100   | %        | ≥0    | Word      | R               |
| 4557H  | 17751      | V3(V23) 55th Harmonic | THD=Rx/100   | %        | ≥0    | Word      | R               |
| 4558H  | 17752      | V3(V23) 56th Harmonic | THD=Rx/100   | %        | ≥0    | Word      | R               |
| 4559H  | 17753      | V3(V23) 57th Harmonic | THD=Rx/100   | %        | ≥0    | Word      | R               |
| 455AH  | 17754      | V3(V23) 58th Harmonic | THD=Rx/100   | %        | ≥0    | Word      | R               |

| Voltage Harmonics, Even & Odd Harmonics, Crest Factor: 03H |            |                       |              |          |         |           |                 |
|--|------------|-----------------------|--------------|----------|---------|-----------|-----------------|
| Address(H)   | Address(D) | Parameter             | Relationship | Property | Range   | Data Type | Access Property |
| 455BH  | 17755      | V3(V23) 59th Harmonic | THD=Rx/100   | %        | ≥0      | Word      | R               |
| 455CH  | 17756      | V3(V23) 60th Harmonic | THD=Rx/100   | %        | ≥0      | Word      | R               |
| 455DH  | 17757      | V3(V23) 61st Harmonic | THD=Rx/100   | %        | ≥0      | Word      | R               |
| 455EH  | 17758      | V3(V23) 62nd Harmonic | THD=Rx/100   | %        | ≥0      | Word      | R               |
| 455FH  | 17759      | V3(V23) 63rd Harmonic | THD=Rx/100   | %        | ≥0      | Word      | R               |
| 40C4H  | 16580      | Odd THD_V3(V23)       | THD=Rx/100   | %        | ≥0      | Word      | R               |
| 40C5H  | 16581      | Even THD_V3(V23)      | THD=Rx/100   | %        | ≥0      | Word      | R               |
| 40C6H  | 16582      | Crest Factor V3(V23)  | CF=Rx/100    | %        | 0-65535 | Word      | R               |
| 40C7H  | 16583      | THDD_V3(V23)          | THFF=Rx/100  | %        | ≥0      | Word      | R               |

**I1 Current Harmonics**

Table 6-31

| Current Harmonics, Even & Odd Harmonics, K Factor: 03H Read |            |                  |              |          |       |           |                 |
|---|------------|------------------|--------------|----------|-------|-----------|-----------------|
| Address(H)  | Address(D) | Parameter        | Relationship | Property | Range | Data Type | Access Property |
| 40C8H   | 16584      | I1 2nd Harmonic  | THD=Rx/100   | %        | ≥0    | Word      | R               |
| 40C9H   | 16585      | I1 3rd Harmonic  | THD=Rx/100   | %        | ≥0    | Word      | R               |
| 40CAH   | 16586      | I1 4th Harmonic  | THD=Rx/100   | %        | ≥0    | Word      | R               |
| 40CBH   | 16587      | I1 5th Harmonic  | THD=Rx/100   | %        | ≥0    | Word      | R               |
| 40CCH   | 16588      | I1 6th Harmonic  | THD=Rx/100   | %        | ≥0    | Word      | R               |
| 40CDH   | 16589      | I1 7th Harmonic  | THD=Rx/100   | %        | ≥0    | Word      | R               |
| 40CEH   | 16590      | I1 8th Harmonic  | THD=Rx/100   | %        | ≥0    | Word      | R               |
| 40CFH   | 16591      | I1 9th Harmonic  | THD=Rx/100   | %        | ≥0    | Word      | R               |
| 40D0H   | 16592      | I1 10th Harmonic | THD=Rx/100   | %        | ≥0    | Word      | R               |
| 40D1H   | 16593      | I1 11th Harmonic | THD=Rx/100   | %        | ≥0    | Word      | R               |
| 40D2H   | 16594      | I1 12th Harmonic | THD=Rx/100   | %        | ≥0    | Word      | R               |
| 40D3H   | 16595      | I1 13th Harmonic | THD=Rx/100   | %        | ≥0    | Word      | R               |
| 40D4H   | 16596      | I1 14th Harmonic | THD=Rx/100   | %        | ≥0    | Word      | R               |

## Acuvim II Series Power Meter

| Current Harmonics, Even & Odd Harmonics, K Factor: 03H Read |            |                  |              |          |       |           |                 |
|---|------------|------------------|--------------|----------|-------|-----------|-----------------|
| Address(H)  | Address(D) | Parameter        | Relationship | Property | Range | Data Type | Access Property |
| 40D5H   | 16597      | I1 15th Harmonic | THD=Rx/100   | %        | ≥0    | Word      | R               |
| 40D6H   | 16598      | I1 16th Harmonic | THD=Rx/100   | %        | ≥0    | Word      | R               |
| 40D7H   | 16599      | I1 17th Harmonic | THD=Rx/100   | %        | ≥0    | Word      | R               |
| 40D8H   | 16600      | I1 18th Harmonic | THD=Rx/100   | %        | ≥0    | Word      | R               |
| 40D9H   | 16601      | I1 19th Harmonic | THD=Rx/100   | %        | ≥0    | Word      | R               |
| 40DAH   | 16602      | I1 20th Harmonic | THD=Rx/100   | %        | ≥0    | Word      | R               |
| 40DBH   | 16603      | I1 21st Harmonic | THD=Rx/100   | %        | ≥0    | Word      | R               |
| 40DCH   | 16604      | I1 22nd Harmonic | THD=Rx/100   | %        | ≥0    | Word      | R               |
| 40DDH   | 16605      | I1 23rd Harmonic | THD=Rx/100   | %        | ≥0    | Word      | R               |
| 40DEH   | 16606      | I1 24th Harmonic | THD=Rx/100   | %        | ≥0    | Word      | R               |
| 40DFH   | 16607      | I1 25th Harmonic | THD=Rx/100   | %        | ≥0    | Word      | R               |
| 40E0H   | 16608      | I1 26th Harmonic | THD=Rx/100   | %        | ≥0    | Word      | R               |
| 40E1H   | 16609      | I1 27th Harmonic | THD=Rx/100   | %        | ≥0    | Word      | R               |
| 40E2H   | 16610      | I1 28th Harmonic | THD=Rx/100   | %        | ≥0    | Word      | R               |
| 40E3H   | 16611      | I1 29th Harmonic | THD=Rx/100   | %        | ≥0    | Word      | R               |
| 40E4H   | 16612      | I1 30th Harmonic | THD=Rx/100   | %        | ≥0    | Word      | R               |
| 40E5H   | 16613      | I1 31st Harmonic | THD=Rx/100   | %        | ≥0    | Word      | R               |
| 4560H   | 17760      | I1 32nd Harmonic | THD=Rx/100   | %        | ≥0    | Word      | R               |
| 4561H   | 17762      | I1 33rd Harmonic | THD=Rx/100   | %        | ≥0    | Word      | R               |
| 4562H   | 17763      | I1 34th Harmonic | THD=Rx/100   | %        | ≥0    | Word      | R               |
| 4563H   | 17764      | I1 35th Harmonic | THD=Rx/100   | %        | ≥0    | Word      | R               |
| 4564H   | 17765      | I1 36th Harmonic | THD=Rx/100   | %        | ≥0    | Word      | R               |
| 4565H   | 17765      | I1 37th Harmonic | THD=Rx/100   | %        | ≥0    | Word      | R               |
| 4566H   | 17766      | I1 38th Harmonic | THD=Rx/100   | %        | ≥0    | Word      | R               |
| 4567H   | 17767      | I1 39th Harmonic | THD=Rx/100   | %        | ≥0    | Word      | R               |
| 4568H   | 17768      | I1 40th Harmonic | THD=Rx/100   | %        | ≥0    | Word      | R               |
| 4569H   | 17769      | I1 41st Harmonic | THD=Rx/100   | %        | ≥0    | Word      | R               |
| 456AH   | 17770      | I1 42nd Harmonic | THD=Rx/100   | %        | ≥0    | Word      | R               |
| 456BH   | 17771      | I1 43rd Harmonic | THD=Rx/100   | %        | ≥0    | Word      | R               |
| 456CH   | 17772      | I1 44th Harmonic | THD=Rx/100   | %        | ≥0    | Word      | R               |

| Current Harmonics, Even & Odd Harmonics, K Factor: 03H Read |            |                  |              |          |       |           |                 |
|---|------------|------------------|--------------|----------|-------|-----------|-----------------|
| Address(H)  | Address(D) | Parameter        | Relationship | Property | Range | Data Type | Access Property |
| 456DH   | 17773      | I1 45th Harmonic | THD=Rx/100   | %        | ≥0    | Word      | R               |
| 456EH   | 17774      | I1 46th Harmonic | THD=Rx/100   | %        | ≥0    | Word      | R               |
| 456FH   | 17775      | I1 47th Harmonic | THD=Rx/100   | %        | ≥0    | Word      | R               |
| 4570H   | 17776      | I1 48th Harmonic | THD=Rx/100   | %        | ≥0    | Word      | R               |
| 4571H   | 17777      | I1 49th Harmonic | THD=Rx/100   | %        | ≥0    | Word      | R               |
| 4572H   | 17778      | I1 50th Harmonic | THD=Rx/100   | %        | ≥0    | Word      | R               |
| 4573H   | 17779      | I1 51st Harmonic | THD=Rx/100   | %        | ≥0    | Word      | R               |
| 4574H   | 17780      | I1 52nd Harmonic | THD=Rx/100   | %        | ≥0    | Word      | R               |
| 4575H   | 17781      | I1 53rd Harmonic | THD=Rx/100   | %        | ≥0    | Word      | R               |
| 4576H   | 17782      | I1 54th Harmonic | THD=Rx/100   | %        | ≥0    | Word      | R               |
| 4577H   | 17783      | I1 55th Harmonic | THD=Rx/100   | %        | ≥0    | Word      | R               |
| 4578H   | 17784      | I1 56th Harmonic | THD=Rx/100   | %        | ≥0    | Word      | R               |
| 4579H   | 17785      | I1 57th Harmonic | THD=Rx/100   | %        | ≥0    | Word      | R               |
| 457AH   | 17786      | I1 58th Harmonic | THD=Rx/100   | %        | ≥0    | Word      | R               |
| 457BH   | 17787      | I1 59th Harmonic | THD=Rx/100   | %        | ≥0    | Word      | R               |
| 457CH   | 17788      | I1 60th Harmonic | THD=Rx/100   | %        | ≥0    | Word      | R               |
| 457DH   | 17789      | I1 61st Harmonic | THD=Rx/100   | %        | ≥0    | Word      | R               |
| 457EH   | 17790      | I1 62nd Harmonic | THD=Rx/100   | %        | ≥0    | Word      | R               |
| 457FH   | 17791      | I1 63rd Harmonic | THD=Rx/100   | %        | ≥0    | Word      | R               |
| 40E6H   | 16614      | Odd THD_I1       | THD=Rx/100   | %        | ≥0    | Word      | R               |
| 40E7H   | 16615      | Even_THD_I1      | THD=Rx/100   | %        | ≥0    | Word      | R               |
| 40E8H   | 16616      | K Factor of I1   | CF=Rx/100    | %        | ≥0    | Word      | R               |

I2 Current Harmonics

Table 6-32

| Current Harmonics, Even & Odd Harmonics, K Factor: 03H Read |            |                 |              |          |       |           |                 |
|---|------------|-----------------|--------------|----------|-------|-----------|-----------------|
| Address(H)  | Address(D) | Parameter       | Relationship | Property | Range | Data Type | Access Property |
| 40E9H   | 16617      | I2 2nd Harmonic | THD=Rx/100   | %        | ≥0    | Word      | R               |
| 40EAH   | 16618      | I2 3rd Harmonic | THD=Rx/100   | %        | ≥0    | Word      | R               |

## Acuvim II Series Power Meter

| Current Harmonics, Even & Odd Harmonics, K Factor: 03H Read |            |                  |              |          |       |           |                 |
|---|------------|------------------|--------------|----------|-------|-----------|-----------------|
| Address(H)  | Address(D) | Parameter        | Relationship | Property | Range | Data Type | Access Property |
| 40EBH   | 16619      | I2 4th Harmonic  | THD=Rx/100   | %        | ≥0    | Word      | R               |
| 40ECH   | 16620      | I2 5th Harmonic  | THD=Rx/100   | %        | ≥0    | Word      | R               |
| 40EDH   | 16621      | I2 6th Harmonic  | THD=Rx/100   | %        | ≥0    | Word      | R               |
| 40EEH   | 16622      | I2 7th Harmonic  | THD=Rx/100   | %        | ≥0    | Word      | R               |
| 40EFH   | 16623      | I2 8th Harmonic  | THD=Rx/100   | %        | ≥0    | Word      | R               |
| 40F0H   | 16624      | I2 9th Harmonic  | THD=Rx/100   | %        | ≥0    | Word      | R               |
| 40F1H   | 16625      | I2 10th Harmonic | THD=Rx/100   | %        | ≥0    | Word      | R               |
| 40F2H   | 16626      | I2 11th Harmonic | THD=Rx/100   | %        | ≥0    | Word      | R               |
| 40F3H   | 16627      | I2 12th Harmonic | THD=Rx/100   | %        | ≥0    | Word      | R               |
| 40F4H   | 16628      | I2 13th Harmonic | THD=Rx/100   | %        | ≥0    | Word      | R               |
| 40F5H   | 16629      | I2 14th Harmonic | THD=Rx/100   | %        | ≥0    | Word      | R               |
| 40F6H   | 16630      | I2 15th Harmonic | THD=Rx/100   | %        | ≥0    | Word      | R               |
| 40F7H   | 16631      | I2 16th Harmonic | THD=Rx/100   | %        | ≥0    | Word      | R               |
| 40F8H   | 16632      | I2 17th Harmonic | THD=Rx/100   | %        | ≥0    | Word      | R               |
| 40F9H   | 16633      | I2 18th Harmonic | THD=Rx/100   | %        | ≥0    | Word      | R               |
| 40FAH   | 16634      | I2 19th Harmonic | THD=Rx/100   | %        | ≥0    | Word      | R               |
| 40FBH   | 16635      | I2 20th Harmonic | THD=Rx/100   | %        | ≥0    | Word      | R               |
| 40FCH   | 16636      | I2 21st Harmonic | THD=Rx/100   | %        | ≥0    | Word      | R               |
| 40FDH   | 16637      | I2 22nd Harmonic | THD=Rx/100   | %        | ≥0    | Word      | R               |
| 40FEH   | 16638      | I2 23rd Harmonic | THD=Rx/100   | %        | ≥0    | Word      | R               |
| 40FFH   | 16639      | I2 24th Harmonic | THD=Rx/100   | %        | ≥0    | Word      | R               |
| 4100H   | 16640      | I2 25th Harmonic | THD=Rx/100   | %        | ≥0    | Word      | R               |
| 4101H   | 16641      | I2 26th Harmonic | THD=Rx/100   | %        | ≥0    | Word      | R               |
| 4102H   | 16642      | I2 27th Harmonic | THD=Rx/100   | %        | ≥0    | Word      | R               |
| 4103H   | 16643      | I2 28th Harmonic | THD=Rx/100   | %        | ≥0    | Word      | R               |
| 4104H   | 16644      | I2 29th Harmonic | THD=Rx/100   | %        | ≥0    | Word      | R               |
| 4105H   | 16645      | I2 30th Harmonic | THD=Rx/100   | %        | ≥0    | Word      | R               |
| 4106H   | 16646      | I2 31st Harmonic | THD=Rx/100   | %        | ≥0    | Word      | R               |
| 4580H   | 17792      | I2 32nd Harmonic | THD=Rx/100   | %        | ≥0    | Word      | R               |
| 4581H   | 17793      | I2 33rd Harmonic | THD=Rx/100   | %        | ≥0    | Word      | R               |

| Current Harmonics, Even & Odd Harmonics, K Factor: 03H Read |            |                  |              |          |       |           |                 |
|---|------------|------------------|--------------|----------|-------|-----------|-----------------|
| Address(H)  | Address(D) | Parameter        | Relationship | Property | Range | Data Type | Access Property |
| 4582H   | 17794      | I2 34th Harmonic | THD=Rx/100   | %        | ≥0    | Word      | R               |
| 4583H   | 17795      | I2 35th Harmonic | THD=Rx/100   | %        | ≥0    | Word      | R               |
| 4584H   | 17796      | I2 36th Harmonic | THD=Rx/100   | %        | ≥0    | Word      | R               |
| 4585H   | 17797      | I2 37th Harmonic | THD=Rx/100   | %        | ≥0    | Word      | R               |
| 4586H   | 17798      | I2 38th Harmonic | THD=Rx/100   | %        | ≥0    | Word      | R               |
| 4587H   | 17799      | I2 39th Harmonic | THD=Rx/100   | %        | ≥0    | Word      | R               |
| 4588H   | 17800      | I2 40th Harmonic | THD=Rx/100   | %        | ≥0    | Word      | R               |
| 4589H   | 17801      | I2 41st Harmonic | THD=Rx/100   | %        | ≥0    | Word      | R               |
| 458AH   | 17802      | I2 42nd Harmonic | THD=Rx/100   | %        | ≥0    | Word      | R               |
| 458BH   | 17803      | I2 43rd Harmonic | THD=Rx/100   | %        | ≥0    | Word      | R               |
| 458CH   | 17804      | I2 44th Harmonic | THD=Rx/100   | %        | ≥0    | Word      | R               |
| 458DH   | 17805      | I2 45th Harmonic | THD=Rx/100   | %        | ≥0    | Word      | R               |
| 458EH   | 17806      | I2 46th Harmonic | THD=Rx/100   | %        | ≥0    | Word      | R               |
| 458FH   | 17807      | I2 47th Harmonic | THD=Rx/100   | %        | ≥0    | Word      | R               |
| 4590H   | 17808      | I2 48th Harmonic | THD=Rx/100   | %        | ≥0    | Word      | R               |
| 4591H   | 17809      | I2 49th Harmonic | THD=Rx/100   | %        | ≥0    | Word      | R               |
| 4592H   | 17810      | I2 50th Harmonic | THD=Rx/100   | %        | ≥0    | Word      | R               |
| 4593H   | 17811      | I2 51st Harmonic | THD=Rx/100   | %        | ≥0    | Word      | R               |
| 4594H   | 17812      | I2 52nd Harmonic | THD=Rx/100   | %        | ≥0    | Word      | R               |
| 4595H   | 17813      | I2 53rd Harmonic | THD=Rx/100   | %        | ≥0    | Word      | R               |
| 4596H   | 17814      | I2 54th Harmonic | THD=Rx/100   | %        | ≥0    | Word      | R               |
| 4597H   | 17815      | I2 55th Harmonic | THD=Rx/100   | %        | ≥0    | Word      | R               |
| 4598H   | 17816      | I2 56th Harmonic | THD=Rx/100   | %        | ≥0    | Word      | R               |
| 4599H   | 17817      | I2 57th Harmonic | THD=Rx/100   | %        | ≥0    | Word      | R               |
| 459AH   | 17818      | I2 58th Harmonic | THD=Rx/100   | %        | ≥0    | Word      | R               |
| 459BH   | 17819      | I2 59th Harmonic | THD=Rx/100   | %        | ≥0    | Word      | R               |
| 459CH   | 17820      | I2 60th Harmonic | THD=Rx/100   | %        | ≥0    | Word      | R               |
| 459DH   | 17821      | I2 61st Harmonic | THD=Rx/100   | %        | ≥0    | Word      | R               |
| 459EH   | 17822      | I2 62nd Harmonic | THD=Rx/100   | %        | ≥0    | Word      | R               |
| 459FH   | 17823      | I2 63rd Harmonic | THD=Rx/100   | %        | ≥0    | Word      | R               |

## Acuvim II Series Power Meter

| Current Harmonics, Even & Odd Harmonics, K Factor: 03H Read |            |                |              |          |       |           |                 |
|---|------------|----------------|--------------|----------|-------|-----------|-----------------|
| Address(H)  | Address(D) | Parameter      | Relationship | Property | Range | Data Type | Access Property |
| 4107H   | 16647      | Odd THD_I2     | THD=Rx/100   | %        | ≥0    | Word      | R               |
| 4108H   | 16648      | Even THD_I2    | THD=Rx/100   | %        | ≥0    | Word      | R               |
| 4109H   | 16649      | K Factor of I2 | CF=Rx/100    | %        | ≥0    | Word      | R               |

### I3 Current Harmonics

Table 6-33

| Current Harmonics, Even & Odd Harmonics, K Factor: 03H Read |            |                  |              |          |       |           |                 |
|---|------------|------------------|--------------|----------|-------|-----------|-----------------|
| Address(H)  | Address(D) | Parameter        | Relationship | Property | Range | Data Type | Access Property |
| 410AH   | 16650      | I3 2nd Harmonic  | THD=Rx/100   | %        | ≥0    | Word      | R               |
| 410BH   | 16551      | I3 3rd Harmonic  | THD=Rx/100   | %        | ≥0    | Word      | R               |
| 410CH   | 16652      | I3 4th Harmonic  | THD=Rx/100   | %        | ≥0    | Word      | R               |
| 410DH   | 16553      | I3 5th Harmonic  | THD=Rx/100   | %        | ≥0    | Word      | R               |
| 410EH   | 16554      | I3 6th Harmonic  | THD=Rx/100   | %        | ≥0    | Word      | R               |
| 410FH   | 16555      | I3 7th Harmonic  | THD=Rx/100   | %        | ≥0    | Word      | R               |
| 4110H   | 16556      | I3 8th Harmonic  | THD=Rx/100   | %        | ≥0    | Word      | R               |
| 4111H   | 16657      | I3 9th Harmonic  | THD=Rx/100   | %        | ≥0    | Word      | R               |
| 4112H   | 16558      | I3 10th Harmonic | THD=Rx/100   | %        | ≥0    | Word      | R               |
| 4113H   | 16559      | I3 11th Harmonic | THD=Rx/100   | %        | ≥0    | Word      | R               |
| 4114H   | 16660      | I3 12th Harmonic | THD=Rx/100   | %        | ≥0    | Word      | R               |
| 4115H   | 16661      | I3 13th Harmonic | THD=Rx/100   | %        | ≥0    | Word      | R               |
| 4116H   | 16662      | I3 14th Harmonic | THD=Rx/100   | %        | ≥0    | Word      | R               |
| 4117H   | 16663      | I3 15th Harmonic | THD=Rx/100   | %        | ≥0    | Word      | R               |
| 4118H   | 16664      | I3 16th Harmonic | THD=Rx/100   | %        | ≥0    | Word      | R               |
| 4119H   | 16665      | I3 17th Harmonic | THD=Rx/100   | %        | ≥0    | Word      | R               |
| 411AH   | 16666      | I3 18th Harmonic | THD=Rx/100   | %        | ≥0    | Word      | R               |
| 411BH   | 16667      | I3 19th Harmonic | THD=Rx/100   | %        | ≥0    | Word      | R               |
| 411CH   | 16668      | I3 20th Harmonic | THD=Rx/100   | %        | ≥0    | Word      | R               |
| 411DH   | 16669      | I3 21st Harmonic | THD=Rx/100   | %        | ≥0    | Word      | R               |
| 411EH   | 16670      | I3 22nd Harmonic | THD=Rx/100   | %        | ≥0    | Word      | R               |

| Current Harmonics, Even & Odd Harmonics, K Factor: 03H Read |            |                  |              |          |       |           |                 |
|---|------------|------------------|--------------|----------|-------|-----------|-----------------|
| Address(H)  | Address(D) | Parameter        | Relationship | Property | Range | Data Type | Access Property |
| 411FH   | 16671      | I3 23rd Harmonic | THD=Rx/100   | %        | ≥0    | Word      | R               |
| 4120H   | 16672      | I3 24th Harmonic | THD=Rx/100   | %        | ≥0    | Word      | R               |
| 4121H   | 16673      | I3 25th Harmonic | THD=Rx/100   | %        | ≥0    | Word      | R               |
| 4122H   | 16674      | I3 26th Harmonic | THD=Rx/100   | %        | ≥0    | Word      | R               |
| 4123H   | 16675      | I3 27th Harmonic | THD=Rx/100   | %        | ≥0    | Word      | R               |
| 4124H   | 16676      | I3 28th Harmonic | THD=Rx/100   | %        | ≥0    | Word      | R               |
| 4125H   | 16677      | I3 29th Harmonic | THD=Rx/100   | %        | ≥0    | Word      | R               |
| 4126H   | 16678      | I3 30th Harmonic | THD=Rx/100   | %        | ≥0    | Word      | R               |
| 4127H   | 16679      | I3 31st Harmonic | THD=Rx/100   | %        | ≥0    | Word      | R               |
| 45A0H   | 17824      | I3 32nd Harmonic | THD=Rx/100   | %        | ≥0    | Word      | R               |
| 45A1H   | 17825      | I3 33rd Harmonic | THD=Rx/100   | %        | ≥0    | Word      | R               |
| 45A2H   | 17826      | I3 34th Harmonic | THD=Rx/100   | %        | ≥0    | Word      | R               |
| 45A3H   | 17827      | I3 35th Harmonic | THD=Rx/100   | %        | ≥0    | Word      | R               |
| 45A4H   | 17828      | I3 36th Harmonic | THD=Rx/100   | %        | ≥0    | Word      | R               |
| 45A5H   | 17829      | I3 37th Harmonic | THD=Rx/100   | %        | ≥0    | Word      | R               |
| 45A6H   | 17830      | I3 38th Harmonic | THD=Rx/100   | %        | ≥0    | Word      | R               |
| 45A7H   | 17831      | I3 39th Harmonic | THD=Rx/100   | %        | ≥0    | Word      | R               |
| 45A8H   | 17832      | I3 40th Harmonic | THD=Rx/100   | %        | ≥0    | Word      | R               |
| 45A9H   | 17833      | I3 41st Harmonic | THD=Rx/100   | %        | ≥0    | Word      | R               |
| 45AAH   | 17834      | I3 42nd Harmonic | THD=Rx/100   | %        | ≥0    | Word      | R               |
| 45ABH   | 17835      | I3 43rd Harmonic | THD=Rx/100   | %        | ≥0    | Word      | R               |
| 45ACH   | 17836      | I3 44th Harmonic | THD=Rx/100   | %        | ≥0    | Word      | R               |
| 45ADH   | 17837      | I3 45th Harmonic | THD=Rx/100   | %        | ≥0    | Word      | R               |
| 45AEH   | 17838      | I3 46th Harmonic | THD=Rx/100   | %        | ≥0    | Word      | R               |
| 45AFH   | 17839      | I3 47th Harmonic | THD=Rx/100   | %        | ≥0    | Word      | R               |
| 45B0H   | 17840      | I3 48th Harmonic | THD=Rx/100   | %        | ≥0    | Word      | R               |
| 45B1H   | 17841      | I3 49th Harmonic | THD=Rx/100   | %        | ≥0    | Word      | R               |
| 45B2H   | 17842      | I3 50th Harmonic | THD=Rx/100   | %        | ≥0    | Word      | R               |
| 45B3H   | 17843      | I3 51st Harmonic | THD=Rx/100   | %        | ≥0    | Word      | R               |
| 45B4H   | 17844      | I3 52nd Harmonic | THD=Rx/100   | %        | ≥0    | Word      | R               |

## Acuvim II Series Power Meter

| Current Harmonics, Even & Odd Harmonics, K Factor: 03H Read |            |                  |              |          |       |           |                 |
|---|------------|------------------|--------------|----------|-------|-----------|-----------------|
| Address(H)  | Address(D) | Parameter        | Relationship | Property | Range | Data Type | Access Property |
| 45B5H   | 17845      | I3 53rd Harmonic | THD=Rx/100   | %        | ≥0    | Word      | R               |
| 45B6H   | 17846      | I3 54th Harmonic | THD=Rx/100   | %        | ≥0    | Word      | R               |
| 45B7H   | 17847      | I3 55th Harmonic | THD=Rx/100   | %        | ≥0    | Word      | R               |
| 45B8H   | 17848      | I3 56th Harmonic | THD=Rx/100   | %        | ≥0    | Word      | R               |
| 45B9H   | 17849      | I3 57th Harmonic | THD=Rx/100   | %        | ≥0    | Word      | R               |
| 45BAH   | 17850      | I3 58th Harmonic | THD=Rx/100   | %        | ≥0    | Word      | R               |
| 45BBH   | 17851      | I3 59th Harmonic | THD=Rx/100   | %        | ≥0    | Word      | R               |
| 45BCH   | 17852      | I3 60th Harmonic | THD=Rx/100   | %        | ≥0    | Word      | R               |
| 45BDH   | 17853      | I3 61st Harmonic | THD=Rx/100   | %        | ≥0    | Word      | R               |
| 45BEH   | 17854      | I3 62nd Harmonic | THD=Rx/100   | %        | ≥0    | Word      | R               |
| 45BFH   | 17855      | I3 63rd Harmonic | THD=Rx/100   | %        | ≥0    | Word      | R               |
| 4128H   | 16680      | Odd THD_I3       | THD=Rx/100   | %        | ≥0    | Word      | R               |
| 4129H   | 16681      | Even THD_I3      | THD=Rx/100   | %        | ≥0    | Word      | R               |
| 412AH   | 16682      | K Factor of I3   | CF=Rx/100    | %        | ≥0    | Word      | R               |

**NOTE:** When selecting 400Hz type, harmonics support 2nd~15th.

### 6.3.11 Max & Min Values

Records MAX/MIN value and timestamp.

#### Maximum Values

Table 6-34

| MAX: 03H Read   |                 |           |                     |          |                 |           |                 |
|-----------------|-----------------|-----------|---------------------|----------|-----------------|-----------|-----------------|
| Address(H)      | Address(D)      | Parameter | Relationship        | Property | Range           | Data Type | Access Property |
| 4136H           | 16694           | Max of V1 | $(Rx*(PT1/PT2))/10$ | V        | 32768~<br>32767 | int       | R               |
| 4137H<br>-413CH | 16695-<br>16700 | Timestamp | YYYY:MM:DD:hh:mm:ss |          |                 | int       | R               |
| 413DH           | 16701           | Max of V2 | $(Rx*(PT1/PT2))/10$ | V        | 32768~<br>32767 | int       | R               |
| 413EH-<br>4143H | 16702-<br>16707 | Timestamp | YYYY:MM:DD:hh:mm:ss |          |                 | int       | R               |
| 4144H           | 16708           | Max of V3 | $(Rx*(PT1/PT2))/10$ | V        | 32768~<br>32767 | int       | R               |

| MAX: 03H Read |             |                       |                                 |          |             |           |                 |
|---------------|-------------|-----------------------|---------------------------------|----------|-------------|-----------|-----------------|
| Address(H)    | Address(D)  | Parameter             | Relationship                    | Property | Range       | Data Type | Access Property |
| 4145H-414AH   | 16709-16714 | Timestamp             | YYYY:MM:DD:hh:mm:ss             |          |             | int       | R               |
| 414BH         | 16715       | Max of V12            | $(Rx*(PT1/PT2))/10$             | V        | 32768~32767 | int       | R               |
| 414CH-4151H   | 16716-16721 | Timestamp             | YYYY:MM:DD:hh:mm:ss             |          |             | int       | R               |
| 4152H         | 16722       | Max of V23            | $(Rx*(PT1/PT2))/10$             | V        | 32768~32767 | int       | R               |
| 4153H-4158H   | 16723-16728 | Timestamp             | YYYY:MM:DD:hh:mm:ss             |          |             | int       | R               |
| 4159H         | 16729       | Max of V31            | $(Rx*(PT1/PT2))/10$             | V        | 32768~32767 | int       | R               |
| 415AH-415FH   | 16730-16735 | Timestamp             | YYYY:MM:DD:hh:mm:ss             |          |             | int       | R               |
| 4160H         | 16736       | Max of I1             | $(Rx*(CT1/CT2))/1000$           | A        | 32768~32767 | int       | R               |
| 4161H-4166H   | 16737-16742 | Timestamp             | YYYY:MM:DD:hh:mm:ss             |          |             | int       | R               |
| 4167H         | 16743       | Max of I2             | $(Rx*(CT1/CT2))/1000$           | A        | 32768~32767 | int       | R               |
| 4168H-416DH   | 16744-16749 | Timestamp             | YYYY:MM:DD:hh:mm:ss             |          |             | int       | R               |
| 416EH         | 16750       | Max of I3             | $(Rx*(CT1/CT2))/1000$           | A        | 32768~32767 | int       | R               |
| 416FH-4174H   | 16751-16756 | Timestamp             | YYYY:MM:DD:hh:mm:ss             |          |             | int       | R               |
| 4175H         | 16757       | Max of System Power   | $(Rx*(CT1/CT2)*(PT1/PT2))/1000$ | kW       | 32768~32767 | int       | R               |
| 4176H-417BH   | 16758-16763 | Timestamp             | YYYY:MM:DD:hh:mm:ss             |          |             | int       | R               |
| 417CH         | 16764       | Max of Reactive Power | $(Rx*(CT1/CT2)*(PT1/PT2))/1000$ | kvar     | 32768~32767 | int       | R               |
| 417DH-4182H   | 16765-16770 | Timestamp             | YYYY:MM:DD:hh:mm:ss             |          |             | int       | R               |
| 4183H         | 16771       | Max of Apparent Power | $(Rx*(CT1/CT2)*(PT1/PT2))/1000$ | kVA      | 32768~32767 | int       | R               |
| 4184H-4189H   | 16772-16777 | Timestamp             | YYYY:MM:DD:hh:mm:ss             |          |             | int       | R               |
| 418AH         | 16778       | Max of Power Factor   | $Rx/1000$                       |          | 32768~32767 | int       | R               |
| 418BH-4190H   | 16779-16784 | Timestamp             | YYYY:MM:DD:hh:mm:ss             |          |             | int       | R               |

## Acuvim II Series Power Meter

| MAX: 03H Read |             |                               |                                 |          |             |           |                 |
|---------------|-------------|-------------------------------|---------------------------------|----------|-------------|-----------|-----------------|
| Address(H)    | Address(D)  | Parameter                     | Relationship                    | Property | Range       | Data Type | Access Property |
| 4191H         | 16785       | Max of Frequency              | Rx/1000                         | Hz       | 32768~32767 | int       | R               |
| 4192H-4197H   | 16786-16791 | Timestamp                     | YYYY:MM:DD:hh:mm:ss             |          |             | int       | R               |
| 4198H         | 16792       | Max of Power Demand           | $(Rx*(CT1/CT2)*(PT1/PT2))/1000$ | kW       | 32768~32767 | int       | R               |
| 4199H-419EH   | 16793-16798 | Timestamp                     | YYYY:MM:DD:hh:mm:ss             |          |             | int       | R               |
| 419FH         | 16799       | Max of Reactive Power Demand  | $(Rx*(CT1/CT2)*(PT1/PT2))/1000$ | kvar     | 32768~32767 | int       | R               |
| 41A0H-41A5H   | 16800-16805 | Timestamp                     | YYYY:MM:DD:hh:mm:ss             |          |             | int       | R               |
| 41A6H         | 16806       | Max of Apparent Power Demand  | $(Rx*(CT1/CT2)*(PT1/PT2))/1000$ | kVA      | 32768~32767 | int       | R               |
| 41A7H-41ACH   | 16807-16812 | Timestamp                     | YYYY:MM:DD:hh:mm:ss             |          |             | int       | R               |
| 4606H         | 17926       | Max of Phase A Current Demand | $(Rx*(CT1/CT2))/1000$           | A        | 32768~32767 | int       | R               |
| 4607H-460CH   | 17927-17932 | Timestamp                     | YYYY:MM:DD:hh:mm:ss             |          |             | int       | R               |
| 460DH         | 17933       | Max of Phase B Current Demand | $(Rx*(CT1/CT2))/1000$           | A        | 32768~32767 | int       | R               |
| 460EH-4613H   | 17934-17939 | Timestamp                     | YYYY:MM:DD:hh:mm:ss             |          |             | int       | R               |
| 4614H         | 17940       | Max of Phase C Current Demand | $(Rx*(CT1/CT2))/1000$           | A        | 32768~32767 | int       | R               |
| 4615H-461AH   | 17941-17946 | Timestamp                     | YYYY:MM:DD:hh:mm:ss             |          |             | int       | R               |
| 41ADH         | 16813       | Max of Voltage Unbalance      | Rx/10                           | %        | 32768~32767 | int       | R               |
| 41AEH-41B3H   | 16814-16819 | Timestamp                     | YYYY:MM:DD:hh:mm:ss             |          |             | int       | R               |
| 41B4H         | 16820       | Max of Current Unbalance      | Rx/10                           | %        | 32768~32767 | int       | R               |
| 41B5H-41BAH   | 16821-16826 | Timestamp                     | YYYY:MM:DD:hh:mm:ss             |          |             | int       | R               |
| 41BBH         | 16827       | Max of THD_V1(V12)            |                                 | %        | 32768~32767 | int       | R               |
| 41BCH-41C1H   | 16828-16833 | Timestamp                     | YYYY:MM:DD:hh:mm:ss             |          |             | int       | R               |

| MAX: 03H Read |             |                    |                     |          |             |           |                 |
|---------------|-------------|--------------------|---------------------|----------|-------------|-----------|-----------------|
| Address(H)    | Address(D)  | Parameter          | Relationship        | Property | Range       | Data Type | Access Property |
| 41C2H         | 16834       | Max of THD_V2(V31) | Rx/100              | %        | 32768~32767 | int       | R               |
| 41C3H-41C8H   | 16835-16840 | Timestamp          | YYYY:MM:DD:hh:mm:ss |          |             | int       | R               |
| 41C9H         | 16841       | Max of THD_V3(V23) | Rx/100              | %        | 32768~32767 | int       | R               |
| 41CAH-41CFH   | 16842-16847 | Timestamp          | YYYY:MM:DD:hh:mm:ss |          |             | int       | R               |
| 41D0H         | 16848       | Max of THD_I1      | Rx/100              | %        | 32768~32767 | int       | R               |
| 41D1H-41D6H   | 16849-16854 | Timestamp          | YYYY:MM:DD:hh:mm:ss |          |             | int       | R               |
| 41D7H         | 16855       | Max of THD_I2      | Rx/100              | %        | 32768~32767 | int       | R               |
| 41D8H-41DDH   | 16856-16861 | Timestamp          | YYYY:MM:DD:hh:mm:ss |          |             | int       | R               |
| 41DEH         | 16862       | Max of THD_I3      | Rx/100              | %        | 32768~32767 | int       | R               |
| 41DFH-41E4H   | 16863-16868 | Timestamp          | YYYY:MM:DD:hh:mm:ss |          |             | int       | R               |

Minimum Values

Table 6-35

| MIN: 03H Read |             |            |                     |          |             |           |                 |
|---------------|-------------|------------|---------------------|----------|-------------|-----------|-----------------|
| Address(H)    | Address(D)  | Parameter  | Relationship        | Property | Range       | Data Type | Access Property |
| 41E5H         | 16869       | Min of V1  | (Rx*(PT1/PT2))/10   | V        | 32768~32767 | int       | R               |
| 41E6H-41EBH   | 16870-16875 | Timestamp  | YYYY:MM:DD:hh:mm:ss |          |             | int       | R               |
| 41ECH         | 16876       | Min of V2  | (Rx*(PT1/PT2))/10   | V        | 32768~32767 | int       | R               |
| 41EDH-41F2H   | 16877-16882 | Timestamp  | YYYY:MM:DD:hh:mm:ss |          |             | int       | R               |
| 41F3H         | 16883       | Min of V3  | (Rx*(PT1/PT2))/10   | V        | 32768~32767 | int       | R               |
| 41F4H-41F9H   | 16884-16889 | Timestamp  | YYYY:MM:DD:hh:mm:ss |          |             | int       | R               |
| 41FAH         | 16890       | Min of V12 | (Rx*(PT1/PT2))/10   | V        | 32768~32767 | int       | R               |
| 41FBH-4200H   | 16891-16896 | Timestamp  | YYYY:MM:DD:hh:mm:ss |          |             | int       | R               |

## Acuvim II Series Power Meter

| MIN: 03H Read |             |                       |                                 |          |             |           |                 |
|---------------|-------------|-----------------------|---------------------------------|----------|-------------|-----------|-----------------|
| Address(H)    | Address(D)  | Parameter             | Relationship                    | Property | Range       | Data Type | Access Property |
| 4201H         | 16897       | Min of V23            | $(Rx*(PT1/PT2))/10$             | V        | 32768~32767 | int       | R               |
| 4202H-4207H   | 16898-16903 | Timestamp             | YYYY:MM:DD:hh:mm:ss             |          |             | int       | R               |
| 4208H         | 16904       | Min of V31            | $(Rx*(PT1/PT2))/10$             | V        | 32768~32767 | int       | R               |
| 4209H-420EH   | 16905-16910 | Timestamp             | YYYY:MM:DD:hh:mm:ss             |          |             | int       | R               |
| 420FH         | 16911       | Min of I1             | $(Rx*(CT1/CT2))/1000$           | A        | 32768~32767 | int       | R               |
| 4210H-4215H   | 16912-16917 | Timestamp             | YYYY:MM:DD:hh:mm:ss             |          |             | int       | R               |
| 4216H         | 16918       | Min of I2             | $(Rx*(CT1/CT2))/1000$           | A        | 32768~32767 | int       | R               |
| 4217H-421CH   | 16919-16924 | Timestamp             | YYYY:MM:DD:hh:mm:ss             |          |             | int       | R               |
| 421DH         | 16925       | Min of I3             | $(Rx*(CT1/CT2))/1000$           | A        | 32768~32767 | int       | R               |
| 421EH-4223H   | 16926-16931 | Timestamp             | YYYY:MM:DD:hh:mm:ss             |          |             | int       | R               |
| 4224H         | 16932       | Min of System Power   | $(Rx*(CT1/CT2)*(PT1/PT2))/1000$ | kW       | 32768~32767 | int       | R               |
| 4225H-422AH   | 16933-16938 | Timestamp             | YYYY:MM:DD:hh:mm:ss             |          |             | int       | R               |
| 422BH         | 16939       | Min of Reactive Power | $(Rx*(CT1/CT2)*(PT1/PT2))/1000$ | kvar     | 32768~32767 | int       | R               |
| 422CH-4231H   | 16940-16945 | Timestamp             | YYYY:MM:DD:hh:mm:ss             |          |             | int       | R               |
| 4232H         | 16946       | Max of Apparent Power | $(Rx*(CT1/CT2)*(PT1/PT2))/1000$ | kVA      | 32768~32767 | int       | R               |
| 4233H-4238H   | 16947-16952 | Timestamp             | YYYY:MM:DD:hh:mm:ss             |          |             | int       | R               |
| 4239H         | 16953       | Min of Power Factor   | $Rx/1000$                       |          | 32768~32767 | int       | R               |
| 423AH-423FH   | 16954-16959 | Timestamp             | YYYY:MM:DD:hh:mm:ss             |          |             | int       | R               |
| 4240H         | 16960       | Max of Frequency      | $Rx/1000$                       | Hz       | 32768~32767 | int       | R               |
| 4241H-4246H   | 16961-16966 | Timestamp             | YYYY:MM:DD:hh:mm:ss             |          |             | int       | R               |
| 4247H         | 16967       | Min of Power Demand   | $(Rx*(CT1/CT2)*(PT1/PT2))/1000$ | kW       | 32768~32767 | int       | R               |

| MIN: 03H Read |             |                              |                                 |          |             |           |                 |
|---------------|-------------|------------------------------|---------------------------------|----------|-------------|-----------|-----------------|
| Address(H)    | Address(D)  | Parameter                    | Relationship                    | Property | Range       | Data Type | Access Property |
| 4248H-424DH   | 16968-16973 | Timestamp                    | YYYY:MM:DD:hh:mm:ss             |          |             | int       | R               |
| 424EH         | 16974       | Max of Reactive Power Demand | $(Rx*(CT1/CT2)*(PT1/PT2))/1000$ | kvar     | 32768~32767 | int       | R               |
| 424FH-4254H   | 16975-16980 | Timestamp                    | YYYY:MM:DD:hh:mm:ss             |          |             | int       | R               |
| 4255H         | 16981       | Max of Apparent Power Demand | $(Rx*(CT1/CT2)*(PT1/PT2))/1000$ | kVA      | 32768~32767 | int       | R               |
| 4256H-425BH   | 16982-16987 | Timestamp                    | YYYY:MM:DD:hh:mm:ss             |          |             | int       | R               |
| 425CH         | 16988       | Min of Voltage Unbalance     | Rx/10                           | %        | 32768~32767 | int       | R               |
| 425DH-4262H   | 16989-16994 | Timestamp                    | YYYY:MM:DD:hh:mm:ss             |          |             | int       | R               |
| 4263H         | 16995       | Min of Current Unbalance     | Rx/10                           | %        | 32768~32767 | int       | R               |
| 4264H-4269H   | 16996-17001 | Timestamp                    | YYYY:MM:DD:hh:mm:ss             |          |             | int       | R               |
| 426AH         | 17002       | Min of THD_V1 (V12)          | Rx/100                          | %        | 32768~32767 | int       | R               |
| 426BH-4270H   | 17003-17008 | Timestamp                    | YYYY:MM:DD:hh:mm:ss             |          |             | int       | R               |
| 4271H         | 17009       | Min of THD_V2 (V31)          | Rx/100                          | %        | 32768~32767 | int       | R               |
| 4272H-4277H   | 17010-17015 | Timestamp                    | YYYY:MM:DD:hh:mm:ss             |          |             | int       | R               |
| 4278H         | 17016       | Min of THD_V3(V23)           | Rx/100                          | %        | 32768~32767 | int       | R               |
| 4279H-427EH   | 17017-17022 | Timestamp                    | YYYY:MM:DD:hh:mm:ss             |          |             | int       | R               |
| 427FH         | 17023       | Min of THD_I1                | Rx/100                          | %        | 32768~32767 | int       | R               |
| 4280H-4285H   | 17024-17029 | Timestamp                    | YYYY:MM:DD:hh:mm:ss             |          |             | int       | R               |
| 4286H         | 17030       | Min of THD_I2                | Rx/100                          | %        | 32768~32767 | int       | R               |
| 4287H-428CH   | 17031-17036 | Timestamp                    | YYYY:MM:DD:hh:mm:ss             |          |             | int       | R               |
| 428DH         | 17037       | Min of THD_I3                | Rx/100                          | %        | 32768~32767 | int       | R               |
| 428EH-4293H   | 17038-17043 | Timestamp                    | YYYY:MM:DD:hh:mm:ss             |          |             | int       | R               |

**NOTE:** The MAX and MIN frequency value should use word data type (0~65535).

### 6.3.12 Phase Angles

All voltage and current phase angles corresponding to V1 (V120) are stored here. You can find out the phase sequence according to them. Data type is "Word".

Table 6-36

| Phase Angles: 03H Read |            |                         |              |        |           |                 |
|------------------------|------------|-------------------------|--------------|--------|-----------|-----------------|
| Address(H)             | Address(D) | Parameter               | Relationship | Range  | Data Type | Access Property |
| 42A0H                  | 17056      | Phase Angle of V2 to V1 | V2=Rx/10     | 0~3600 | Word      | R               |
| 42A1H                  | 17057      | Phase Angle of V3 to V1 | V3=Rx/10     | 0~3600 | Word      | R               |
| 42A2H                  | 17058      | Phase Angle of I1 to V1 | I1=Rx/10     | 0~3600 | Word      | R               |
| 42A3H                  | 17059      | Phase Angle of I2 to V1 | I2=Rx/10     | 0~3600 | Word      | R               |
| 42A4H                  | 17060      | Phase Angle of I3 to V1 | I3=Rx/10     | 0~3600 | Word      | R               |

### 6.3.13 Sequence Component

U1 (U12), I1 consist of a real part and complex part. They have positive sequence, negative sequence, and zero sequence. Data type is "Int."

Table 6-37

| Sequence Component: 03H Read |            |                                      |              |          |              |           |                 |
|------------------------------|------------|--------------------------------------|--------------|----------|--------------|-----------|-----------------|
| Address(H)                   | Address(D) | Parameter                            | Relationship | Property | Range        | Data Type | Access Property |
| 4294H                        | 17044      | Positive Sequence real part of V1    | THD=Rx/100   | %        | -32768~32768 | Word      | R               |
| 4295H                        | 17045      | Positive Sequence complex part of V1 | THD=Rx/100   | %        | -32768~32768 | Word      | R               |
| 4296H                        | 17046      | Negative Sequence real part of V1    | THD=Rx/100   | %        | -32768~32768 | Word      | R               |
| 4297H                        | 17047      | Negative Sequence complex part of V1 | THD=Rx/100   | %        | -32768~32768 | Word      | R               |
| 4298H                        | 17048      | Zero Sequence real part of V1        | THD=Rx/100   | %        | -32768~32768 | Word      | R               |
| 4299H                        | 17049      | Zero Sequence complex part of V1     | THD=Rx/100   | %        | -32768~32768 | Word      | R               |
| 429AH                        | 17050      | Positive Sequence real part of I1    | THD=Rx/100   | %        | -32768~32768 | Word      | R               |
| 429BH                        | 17051      | Positive Sequence complex part of I1 | THD=Rx/100   | %        | -32768~32768 | Word      | R               |
| 429CH                        | 17052      | Negative Sequence real part of I1    | THD=Rx/100   | %        | -32768~32768 | Word      | R               |

| Sequence Component: 03H Read |            |                                      |                         |          |              |           |                 |
|------------------------------|------------|--------------------------------------|-------------------------|----------|--------------|-----------|-----------------|
| Address(H)                   | Address(D) | Parameter                            | Relationship            | Property | Range        | Data Type | Access Property |
| 429DH                        | 17053      | Negative Sequence complex part of I1 | THD=R <sub>x</sub> /100 | %        | -32768~32768 | Word      | R               |
| 429EH                        | 17054      | Zero Sequence real part of I1        | THD=R <sub>x</sub> /100 | %        | -32768~32768 | Word      | R               |
| 29FH                         | 17055      | Zero Sequence complex part of I1     | THD=R <sub>x</sub> /100 | %        | -32768~32768 | Word      | R               |

### 6.3.14 I/O Module Settings

I/O module setting changes will be made only if the corresponding I/O modules are installed, otherwise no changes will be made. Please check the I/O module connection status before doing any settings. Function code: 03H for reading, 10H for writing. Please refer to Chapter 5 Extended Modules for details.

#### AXM-IO11

Table 6-38

| AXM-IO1-1 Settings: 03H Read, 10H Write |                               |         |   |           |          |
|---|-------------------------------|---------|---|-----------|----------|
| Address                                 | Parameters                    | Default | Range   | Data Type | Property |
| 109EH                                   | DI1~6 type                    | 0       | Bit0: DI1, Bit1: DI2, Bit2: DI3, Bit3: DI4<br>Bit4: DI5, Bit5: DI6, 0: DI, 1: Pulse counter | Word      | R/W      |
| 109FH                                   | DI pulse constant             | 0       | 1~65535   | Word      | R/W      |
| 10A0H                                   | Working mode of relay 1 and 2 | 0       | 0: Control output, 1: Alarming output   | Word      | R/W      |
| 10A1H                                   | Output mode of relay 1 and 2  | 0       | 0: Latch, 1: Pulse  | Word      | R/W      |
| 10A2H                                   | Pulse width                   | 50      | 50~3000ms   | Word      | R/W      |

#### AXM-IO21

Table 6-39

| AXM-IO2-1 Settings, 10H Write |                   |         |  |           |          |
|-------------------------------|-------------------|---------|--|-----------|----------|
| Address                       | Parameters        | Default | Range  | Data Type | Property |
| 10A3H                         | DI11~14 type      | 0       | Bit0: DI7, Bit1: DI8, Bit2: DI9, Bit3: DI10<br>0: DI, 1: Pulse counter | Word      | R/W      |
| 10A4H                         | DI pulse constant | 0       | 1~65535  | Word      | R/W      |

## Acuvim II Series Power Meter

| AXM-IO2-1 Settings, 10H Write |                               |         |  |           |          |
|-------------------------------|-------------------------------|---------|--|-----------|----------|
| Address                       | Parameters                    | Default | Range  | Data Type | Property |
| 10A5H                         | Working mode of relay 3 and 4 | 0       | 0: Pulse output, 1: Alarming output  | Word      | R/W      |
| 10A6H                         | Output mode of relay 3 and 4  | 0       | 20~1000ms  | Word      | R/W      |
| 10A7H                         | Pulse width                   | 50      | 0: None, 1: Consumption power<br>2: Generating power<br>3: Absorption reactive power<br>4: Generating reactive power | Word      | R/W      |
| 10A8H                         | AI1, 2 type                   | 1 or 2  | 0: None, 1: Consumption power<br>2: Generating power<br>3: Absorption reactive power<br>4: Generating reactive power | Word      | R/W      |
| 10A9H                         | Pulse width                   | 50      | 0: 0~20mA, 1: 4~20mA, 2: 0~5V, 3: 1~5V   | Word      | R/W      |

## AXM-IO31

Table 6-40

| AXM-IO3-1 Settings: 03H Read, 10H Write |                               |         |   |           |          |
|---|-------------------------------|---------|---|-----------|----------|
| Address                                 | Parameters                    | Default | Range   | Data Type | Property |
| 10AAH                                   | DI11~14 type                  | 0       | Bit0: DI11, Bit1: DI12, Bit2: DI13, Bit3: DI14<br>0: DI, 1: Pulse counter | Word      | R/W      |
| 10ABH                                   | DI pulse constant             | 0       | 1~65535   | Word      | R/W      |
| 10ACH                                   | Working mode of relay 3 and 4 | 0       | 0: Control output, 1: Alarming output                                     | Word      | R/W      |
| 10ADH                                   | Output mode of relay 3 and 4  | 0       | 0: Latch, 1: Pulse  | Word      | R/W      |
| 10AEH                                   | Pulse width                   | 50      | 50~3000ms   | Word      | R/W      |
| 10AFH                                   | AI1, 2 type                   | 1 or 2  | 0: 0~20mA, 1: 4~20mA, 2: 0~5V, 3: 1~5V                                    | Word      | R/W      |

## AXM-IO12

Table 6-41

| AXM-IO1-2 Settings: 03H Read, 10H Write |                               |         |                                       |           |          |
|---|-------------------------------|---------|---------------------------------------|-----------|----------|
| Address                                 | Parameters                    | Default | Range                                 | Data Type | Property |
| 10B0H                                   | DI15~20 type                  | 0       | Bit0: DI15, Bit1: DI16                | Word      | R/W      |
| 10B1H                                   | DI pulse constant (high)      | 0       | 1~65535                               | Word      | R/W      |
| 10B2H                                   | Working mode of relay 5 and 6 | 0       | 0: Control output, 1: Alarming output | Word      | R/W      |
| 10B3H                                   | Output mode of relay 5 and 6  | 0       | 0: Latch, 1: Pulse                    | Word      | R/W      |
| 10B4H                                   | Pulse width                   | 50      | 50~3000ms                             | Word      | R/W      |

## AXM-IO22

Table 6-42

| AXM-IO2-2 Settings: 03H Read, 10H Write |                        |         |  |           |          |
|---|------------------------|---------|--|-----------|----------|
| Address                                 | Parameters             | Default | Range  | Data Type | Property |
| 10B5H                                   | DI21~24 type           | 0       | Bit0: DI21, Bit1: DI22, Bit2: DI23, Bit3: DI24, 0: DI, 1: Pulse counter  | Word      | R/W      |
| 10B6H                                   | DI pulse constant      | 0       | 1~65535  | Word      | R/W      |
| 10B7H                                   | Working mode of DO3, 4 | 0       | 0: Pulse output, 1: Alarming output  | Word      | R/W      |
| 10B8H                                   | DO pulse width         | 20      | 20~1000ms  | Word      | R/W      |
| 10B9H                                   | DO3 output             | 0       | 0: None, 1: Consumption power<br>2: Generating power<br>3: Absorption reactive power<br>4: Generating reactive power | Word      | R/W      |
| 10BAH                                   | DO4 output             | 0       | 0: None, 1: Consumption power<br>2: Generating power<br>3: Absorption reactive power<br>4: Generating reactive power | Word      | R/W      |
| 10BBH                                   | AO3, 4 type            | 1 or 2  | 0: 0~20mA, 1: 4~20mA, 2: 0~5V, 3: 1~5V   | Word      | R/W      |

AXM-IO32

Table 6-43

| AXM-IO3-2 Settings: 03H Read, 10H Write |                               |         |  |           |          |
|---|-------------------------------|---------|--|-----------|----------|
| Address                                 | Parameters                    | Default | Range  | Data Type | Property |
| 10BCH                                   | DI25~28 type                  | 0       | Bit0: DI25, Bit1: DI26, Bit2: DI27, Bit3: DI28<br>0: DI, 1: Pulse constant | Word      | R/W      |
| 10BDH                                   | DI pulse constant             | 0       | 1~65535  | Word      | R/W      |
| 10BEH                                   | Working mode of relay 7 and 8 | 0       | 0: Control output, 1: Alarming output                                      | Word      | R/W      |
| 10BFH                                   | Output mode of relay 7 and 8  | 0       | 0: Latch, 1: Pulse   | Word      | R/W      |
| 10C0H                                   | Pulse width                   | 50      | 50~3000  | Word      | R/W      |
| 10C1H                                   | AI3, 4 type                   | 1 or 2  | 0: 0~20mA, 1: 4~20mA, 2: 0~5V, 3: 1~5V                                     | Word      | R/W      |

AO Parameter Selection

Table 6-44

| AO Parameter Selection: 03H Read, 10H Write |               |         |                               |           |          |
|---|---------------|---------|-------------------------------|-----------|----------|
| Address                                     | Parameters    | Default | Range                         | Data Type | Property |
| 10C2H                                       | AO1 parameter | 0       | Refer to the table 6-45 below | Word      | R/W      |
| 10C3H                                       | AO2 parameter | 0       | Refer to the table 6-45 below | Word      | R/W      |
| 10C4H                                       | AO3 parameter | 0       | Refer to the table 6-45 below | Word      | R/W      |
| 10C5H                                       | AO4 parameter | 0       | Refer to the table 6-45 below | Word      | R/W      |

AO Parameter Translation Table

Table 6-45

| AO Parameter Selection |                     |               |                       |               |                      |
|------------------------|---------------------|---------------|-----------------------|---------------|----------------------|
| Setting Value          | Transforming Object | Setting Value | Transforming Object   | Setting Value | Transforming Object  |
| 0                      | Frequency           | 1             | Va                    | 2             | Vb                   |
| 3                      | Vc                  | 4             | Average phase voltage | 5             | Uab                  |
| 6                      | Ubc                 | 7             | Uca                   | 8             | Average line voltage |
| 9                      | Current of phase A  | 10            | Current of phase B    | 11            | Current of phase C   |
| 12                     | Average current     | 13            | Neutral current       | 14            | Power of phase A     |

| AO Parameter Selection |                           |               |                           |               |                           |
|------------------------|---------------------------|---------------|---------------------------|---------------|---------------------------|
| Setting Value          | Transforming Object       | Setting Value | Transforming Object       | Setting Value | Transforming Object       |
| 15                     | Power of phase B          | 16            | Power of phase C          | 17            | Power of all              |
| 18                     | Reactive power of A       | 19            | Reactive power of phase B | 20            | Reactive power of phase C |
| 21                     | Reactive power of all     | 22            | Apparent power of phase A | 23            | Apparent power of phase B |
| 24                     | Apparent power of phase C | 25            | Apparent power of all     | 26            | PF of A                   |
| 27                     | PF of B                   | 28            | PF of C                   | 29            | PF                        |

### AO Range Configuration

Table 6-46

| AO Parameter Selection: 03H Read, 10H Write |  |         |  |           |          |
|---|--|---------|--|-----------|----------|
| Address                                     | Parameters   | Default | Range  | Data Type | Property |
| 10D0H                                       | AO1 Gradient Number selection of input/output transfer curve | 1       | 1: 1 Gradient<br>2: 2 Gradient<br>3: 3 Gradient                      | INT       | R/W      |
| 10D1H                                       | AO1 following value range setting start point                |         | Please see note  | INT       | R/W      |
| 10D2H                                       | AO1 following value range setting point 2                    |         |  | INT       | R/W      |
| 10D3H                                       | AO1 following value range setting point 3                    |         |  | INT       | R/W      |
| 10D4H                                       | AO1 following value range setting end point                  |         |  | INT       | R/W      |
| 10D5H                                       | AO1 output range setting start point                         |         | AO type of 0~24A or 0~6: 0~4915<br>AO type of 4~24A or 1~6: 819~4915 | INT       | R/W      |
| 10D6H                                       | AO1 output range setting point 2                             |         |  | INT       | R/W      |
| 10D7H                                       | AO1 output range setting point 3                             |         |  | INT       | R/W      |
| 10D8H                                       | AO1 output range setting end point                           |         |  | INT       | R/W      |
| 109H-10E1H                                  | AO2 Gradient Setting (same as AO1)                           |         | Same as AO1  | INT       | R/W      |
| 10E2H-10EAH                                 | AO3 Gradient Setting (same as AO1)                           |         | Same as AO1  | INT       | R/W      |
| 10EBH-10F3H                                 | AO4 Gradient Setting (same as AO1)                           |         | Same as AO1  | INT       | R/W      |

## Acuvim II Series Power Meter

---

### NOTE:

#### 1. AO Gradient Number Selection of input/output transfer curve

When the number is 1, only the AO following value range setting start point, AO following value range setting end point, AO1 output range setting start point, and AO1 output range setting endpoint should be set.

When number is 2, only the AO following value range setting start point, AO1 following value range setting point 2, AO following value range setting end point, AO1 output range setting start point, AO1 output range setting point 2, and AO1 output range setting endpoint should be set.

When number is 3, only the AO following value range setting start point, AO1 following value range setting point 2, AO1 following value range setting point 3, and AO following value range setting end point should be set. At the same time, the AO1 output range setting start point, AO1 output range setting point 2, AO1 output range setting point 3, and AO1 output range setting end point should be set.

#### Following value range setting:

The AO following value range setting start point, AO1 following value range setting point 2, AO1 following value range setting point 3, and AO following value range setting end point are increasing value, while they should be within range of the AO following value. Otherwise, the function of the AO will be affected.

Frequency: When selecting 50Hz or 60Hz type, the frequency range is 45Hz ~ 65Hz and the real setting value is 4500 ~ 6500. When selecting 400Hz type, the frequency range is 300Hz ~ 500Hz and the real setting value is 30000~50000.

Phase voltage V1, V2, V3 and average phase voltage: 0~480V, real setting value is 0~4800.

Line voltage V12, V23, V31 and average line voltage: 0~831V, real setting value is 0~8310.

Current I1, I2, I3 and average current: 0~10A, real setting value is 0~10000.

Power Pa, Pb and Pc: -4800~4800W, real setting value is -4800~4800.

System power: -14400~14400W, real setting value is -14400~14400.

Reactive power Qa, Qb and Qc: -4800~4800 Var, real setting value is -4800~4800.

System reactive power: -14400~14400 Var.

Apparent power Sa, Sb and Sc: 0~4800VA, real setting value is 0~4800.

System apparent power: 0~14400VA, real setting value is 0~14400.

Power factor PFa, PFb, PFc and System power factor: -1~1, real setting value is -1000~1000.

**AO output range setting:**

The AO output value range setting start point, AO1 output value range setting point 2, AO1 output value range setting point 3, and AO output value range setting end point are increasing value, while they should be within range of the AO output value.

When the AO type is 0~20mA, the setting value range is 0~ 4915, and the relationship is mA=setting value\*20/4096.

When the AO type is 4~20mA, the setting value range is 819~ 4915, and the relationship is mA=setting value\*20/4096.

When the AO type is 0~5V, the setting value range is 0~ 4915, and the relationship is V=setting value\*5/4096.

When the AO type is 1~5V, the setting value range is 819~ 4915, and the relationship is V=setting value\*5/4096.

**Counting Pulses on DI**

DI are arranged according to expanded I/O module addresses, user can check on the counting number of DI along with those modules. The DI counting record are stored in a non-volatile memory and will not be erased during power off. They can be reset via communication and panel. Data type is "Dword".

**6.3.15 I/O Module Readings Settings**

**DI Counter**

Table 6-47

| DI Counter: 03H Read |             |        |                          |              |           |                 |
|----------------------|-------------|--------|--------------------------|--------------|-----------|-----------------|
| Address(H)           | Address(D)  | Symbol | Parameter                | Range        | Data Type | Access Property |
| AXM-IO1-1            |             |        |                          |              |           |                 |
| 4349H-434AH          | 17225-17226 | DI_111 | DI1 Pulse Counter Number | 0~4294967295 | Dword     | R               |
| 434BH-434CH          | 17227-17228 | DI_112 | DI2 Pulse Counter Number | 0~4294967295 | Dword     | R               |
| 434DH-434EH          | 17229-17230 | DI_113 | DI3 Pulse Counter Number | 0~4294967295 | Dword     | R               |
| 434FH-4350H          | 17231-17232 | DI_114 | DI4 Pulse Counter number | 0~4294967295 | Dword     | R               |
| 4351H-4352H          | 17233-17234 | DI_115 | DI5 Pulse Counter Number | 0~4294967295 | Dword     | R               |

## Acuvim II Series Power Meter

| DI Counter: 03H Read |             |        |                           |              |           |                 |
|----------------------|-------------|--------|---------------------------|--------------|-----------|-----------------|
| Address(H)           | Address(D)  | Symbol | Parameter                 | Range        | Data Type | Access Property |
| 4353H-4354H          | 17235-17236 | DI_116 | DI6 Pulse Counter Number  | 0~4294967295 | Dword     | R               |
| <b>AXM-IO2-1</b>     |             |        |                           |              |           |                 |
| 4355H-4356H          | 17237-17238 | DI_211 | DI7 Pulse Counter Number  | 0~4294967295 | Dword     | R               |
| 4357H-4358H          | 17239-17240 | DI_212 | DI8 Pulse Counter Number  | 0~4294967295 | Dword     | R               |
| 4359H-435AH          | 17241-17242 | DI_213 | DI9 Pulse Counter Number  | 0~4294967295 | Dword     | R               |
| 435BH-435CH          | 17243-17244 | DI_214 | DI10 Pulse Counter Number | 0~4294967295 | Dword     | R               |
| <b>AXM-IO3-1</b>     |             |        |                           |              |           |                 |
| 435DH-435EH          | 17245-17246 | DI_311 | DI11 Pulse Counter Number | 0~4294967295 | Dword     | R               |
| 435FH-4360H          | 17247-17248 | DI_312 | DI12 Pulse Counter Number | 0~4294967295 | Dword     | R               |
| 4361H-4362H          | 17249-17250 | DI_313 | DI13 Pulse Counter Number | 0~4294967295 | Dword     | R               |
| 4363H-4364H          | 17251-17252 | DI_314 | DI14 Pulse Counter Number | 0~4294967295 | Dword     | R               |
| <b>AXM-IO1-2</b>     |             |        |                           |              |           |                 |
| 4365H-4366H          | 17253-17254 | DI_121 | DI15 Pulse Counter Number | 0~4294967295 | Dword     | R               |
| 4367H-4368H          | 17255-17256 | DI_122 | DI16 Pulse Counter Number | 0~4294967295 | Dword     | R               |
| 4369H-436AH          | 17257-17258 | DI_123 | DI17 Pulse Counter Number | 0~4294967295 | Dword     | R               |
| 436BH-436CH          | 17259-17260 | DI_124 | DI18 Pulse Counter Number | 0~4294967295 | Dword     | R               |
| 436DH-436EH          | 17261-17262 | DI_125 | DI19 Pulse Counter Number | 0~4294967295 | Dword     | R               |
| 436FH-4370H          | 17263-17264 | DI_126 | DI20 Pulse Counter Number | 0~4294967295 | Dword     | R               |
| <b>AXM-IO2-2</b>     |             |        |                           |              |           |                 |
| 4371H-4372H          | 17265-17266 | DI_221 | DI21 Pulse Counter Number | 0~4294967295 | Dword     | R               |
| 4373H-4374H          | 17267-17268 | DI_222 | DI22 Pulse Counter Number | 0~4294967295 | Dword     | R               |
| 4375H-4376H          | 17269-17270 | DI_223 | DI23 Pulse Counter Number | 0~4294967295 | Dword     | R               |
| 4377H-4378H          | 17271-17272 | DI_224 | DI24 Pulse Counter Number | 0~4294967295 | Dword     | R               |

| DI Counter: 03H Read |             |        |                           |              |           |                 |
|----------------------|-------------|--------|---------------------------|--------------|-----------|-----------------|
| Address(H)           | Address(D)  | Symbol | Parameter                 | Range        | Data Type | Access Property |
| <b>AXM-IO3-2</b>     |             |        |                           |              |           |                 |
| 4371H-4372H          | 17265-17266 | DI_221 | DI21 Pulse Counter Number | 0~4294967295 | Dword     | R               |
| 4373H-4374H          | 17267-17268 | DI_222 | DI22 Pulse Counter Number | 0~4294967295 | Dword     | R               |
| 4375H-4376H          | 17269-17270 | DI_223 | DI23 Pulse Counter Number | 0~4294967295 | Dword     | R               |
| 4377H-4378H          | 17271-17272 | DI_224 | DI24 Pulse Counter Number | 0~4294967295 | Dword     | R               |

**DI Status**

Table 6-48

| DI Status: 02H Read |            |        |             |                 |           |                 |
|---------------------|------------|--------|-------------|-----------------|-----------|-----------------|
| Address(H)          | Address(D) | Symbol | Parameter   | Range           | Data Type | Access Property |
| <b>AXM-101-1</b>    |            |        |             |                 |           |                 |
| 0000H               | 0          | DI_111 | DI1 Status  | 0: OFF<br>1: ON | Bit       | R               |
| 0001H               | 1          | DI_112 | DI2 Status  | 0: OFF<br>1: ON | Bit       | R               |
| 0002H               | 2          | DI_113 | DI3 Status  | 0: OFF<br>1: ON | Bit       | R               |
| 0003H               | 3          | DI_114 | DI4 Status  | 0: OFF<br>1: ON | Bit       | R               |
| 0004H               | 4          | DI_115 | DI5 Status  | 0: OFF<br>1: ON | Bit       | R               |
| 0005H               | 5          | DI_116 | DI6 Status  | 0: OFF<br>1: ON | Bit       | R               |
| <b>AXM-IO2-1</b>    |            |        |             |                 |           |                 |
| 0006H               | 6          | DI_211 | DI7 Status  | 0: OFF<br>1: ON | Bit       | R               |
| 0007H               | 7          | DI_212 | DI8 Status  | 0: OFF<br>1: ON | Bit       | R               |
| 0008H               | 8          | DI_213 | DI9 Status  | 0: OFF<br>1: ON | Bit       | R               |
| 0009H               | 9          | DI_214 | DI10 Status | 0: OFF<br>1: ON | Bit       | R               |

## Acuvim II Series Power Meter

| DI Status: 02H Read |            |        |             |                 |           |                 |
|---------------------|------------|--------|-------------|-----------------|-----------|-----------------|
| Address(H)          | Address(D) | Symbol | Parameter   | Range           | Data Type | Access Property |
| <b>AXM-IO3-1</b>    |            |        |             |                 |           |                 |
| 000AH               | 10         | DI_311 | DI11 Status | 0: OFF<br>1: ON | Bit       | R               |
| 000BH               | 11         | DI_312 | DI12 Status | 0: OFF<br>1: ON | Bit       | R               |
| 000CH               | 12         | DI_313 | DI13 Status | 0: OFF<br>1: ON | Bit       | R               |
| 000DH               | 13         | DI_314 | DI14 Status | 0: OFF<br>1: ON | Bit       | R               |
| <b>AXM-IO1-2</b>    |            |        |             |                 |           |                 |
| 000EH               | 14         | DI_121 | DI15 Status | 0: OFF<br>1: ON | Bit       | R               |
| 000FH               | 15         | DI_122 | DI16 Status | 0: OFF<br>1: ON | Bit       | R               |
| 0010H               | 16         | DI_123 | DI17 Status | 0: OFF<br>1: ON | Bit       | R               |
| 0011H               | 17         | DI_124 | DI18 Status | 0: OFF<br>1: ON | Bit       | R               |
| 0012H               | 18         | DI_125 | DI19 Status | 0: OFF<br>1: ON | Bit       | R               |
| 0013H               | 19         | DI_126 | DI20 Status | 0: OFF<br>1: ON | Bit       | R               |
| <b>AXM-IO2-2</b>    |            |        |             |                 |           |                 |
| 0014H               | 20         | DI_221 | DI21 Status | 0: OFF<br>1: ON | Bit       | R               |
| 0015H               | 21         | DI_222 | DI22 Status | 0: OFF<br>1: ON | Bit       | R               |
| 0016H               | 22         | DI_223 | DI23 Status | 0: OFF<br>1: ON | Bit       | R               |
| 0017H               | 23         | DI_224 | DI24 Status | 0: OFF<br>1: ON | Bit       | R               |
| <b>AXM-IO3-2</b>    |            |        |             |                 |           |                 |
| 0018H               | 24         | DI_321 | DI25 Status | 0: OFF<br>1: ON | Bit       | R               |
| 0019H               | 25         | DI_322 | DI26 Status | 0: OFF<br>1: ON | Bit       | R               |

| DI Status: 02H Read |            |        |             |                 |           |                 |
|---------------------|------------|--------|-------------|-----------------|-----------|-----------------|
| Address(H)          | Address(D) | Symbol | Parameter   | Range           | Data Type | Access Property |
| 001AH               | 26         | DI_323 | DI27 Status | 0: OFF<br>1: ON | Bit       | R               |
| 001BH               | 27         | DI_324 | DI28 Status | 0: OFF<br>1: ON | Bit       | R               |

### Analog Input

The output of AI is mapped to the range of 0~4095 according to its sampling value using an algorithm. Data type is "Word".

Table 6-49

| AI Input Value: 03H Read |            |        |                    |        |           |                 |
|--------------------------|------------|--------|--------------------|--------|-----------|-----------------|
| Address(H)               | Address(D) | Symbol | Parameters         | Range  | Data Type | Access Property |
| 4385H                    | 17285      | AI_311 | AI1 Sampling value | 0~4095 | Dword     | R               |
| 4386H                    | 17286      | AI_312 | AI2 Sampling value | 0~4095 | Dword     | R               |
| 4387H                    | 17287      | AI_321 | AI3 Sampling value | 0~4095 | Dword     | R               |
| 4388H                    | 17288      | AI_322 | AI4 Sampling value | 0~4095 | Dword     | R               |

### Analog Output

The output of the AO is the actual value of output. There are 2 output options for AO: V or mA. Over/under limit or data type is "Float".

Table 6-50

| AO Output Value: 03H Read |             |        |              |       |           |                 |
|---------------------------|-------------|--------|--------------|-------|-----------|-----------------|
| Address(H)                | Address(D)  | Symbol | Parameters   | Range | Data Type | Access Property |
| 4389H-438AH               | 17289-17290 | AO_211 | Value of AO1 |       | Float     | R               |
| 438BH-438CH               | 17291-17292 | AO_212 | Value of AO2 |       | Float     | R               |
| 438DH-438EH               | 17293-17294 | AO_221 | Value of AO3 |       | Float     | R               |
| 438FH-4390H               | 17295-17296 | AO_222 | Value of AO4 |       | Float     | R               |

Relay Output

Table 6-51

| DI Status: 02H Read |            |        |            |                 |           |                 |
|---------------------|------------|--------|------------|-----------------|-----------|-----------------|
| Address(H)          | Address(D) | Symbol | Parameters | Range           | Data Type | Access Property |
| <b>AXM-101-1</b>    |            |        |            |                 |           |                 |
| 0000H               | 0          | RO_111 | RO1        | 0:OFF<br>1:ON   | Bit       | R               |
| 0001H               | 1          | RO_112 | RO2        | 0:OFF<br>1:ON   | Bit       | R               |
| <b>AXM-IO3-1</b>    |            |        |            |                 |           |                 |
| 0002H               | 2          | RO_311 | RO3        | 0: OFF<br>1: ON | Bit       | R               |
| 0003H               | 3          | RO_312 | RO4        | 0: OFF<br>1: ON | Bit       | R               |
| <b>AXM-IO1-2</b>    |            |        |            |                 |           |                 |
| 0004H               | 4          | RO_121 | RO5        | 0: OFF<br>1: ON | Bit       | R               |
| 0005H               | 5          | RO_122 | RO6        | 0: OFF<br>1: ON | Bit       | R               |
| <b>AXM-IO3-2</b>    |            |        |            |                 |           |                 |
| 0006H               | 6          | RO_321 | RO7        | 0: OFF<br>1: ON | Bit       | R               |
| 0007H               | 7          | RO_322 | RO8        | 0: OFF<br>1: ON | Bit       | R               |

SOE Records

There are 20 groups of records with the same format. Before gathering SOE records, the selected I/O module must be SOE enabled. If the SOE enabled I/O module is not connected, SOE record logs will not be collected.

Table 6-52

| Address     | Parameters                                    | Code | Range | Data Type | Property |
|-------------|---|------|-------|-----------|----------|
| 4339H~439FH | First group: timestamp:<br>yyy:mm:dd:hh:mm:ms | F3   |       | Word      | R        |
| 43A0H       | First group: DI status                        | F1   |       | Word      | R        |
| 43A1H~4438H | 2nd to 20th group                             |      |       | Word      | R        |

| Address | Parameters   | Code | Range   | Data Type | Property |
|---------|--------------|------|---|-----------|----------|
| 4439H   | Value of A04 | F1   | 0: None<br>1: AXM-IO11<br>2: AXM-IO21<br>3: AXM-IO31<br>4: AXM-IO12<br>5: AXM-IO22<br>6: AXM-IO32 | Word      | R        |

### 6.3.16 SunSpec Registers

Table 6-53

| SunSpec: 03H Read, 10H Write |             |                |   |                    |           |                 |                     |
|------------------------------|-------------|----------------|---|--------------------|-----------|-----------------|---------------------|
| Address(H)                   | Address(D)  | Parameters     | Range                                       | Default            | Data Type | Access Property | Number of Registers |
| C350H-C351H                  | 50000-50001 | SunSpec_ID     | 0x53756e53                                  |                    |           | R               | 2                   |
| C352H                        | 50002       | ID             | 1   |                    | Uint16    | R               | 1                   |
| C353H                        | 50003       | Length         | 65  |                    | String    | R               | 1                   |
| C354H-C363H                  | 50004-50019 | Manufacturer   |   | Accuenergy         | String    | R               | 16                  |
| C364H-C373H                  | 50020-50035 | Model          | Manufacturer Specific Value (32 characters) | Acuvim II          | String    | R               | 16                  |
| C374H-C37BH                  | 50036-50043 | Options        | Manufacturer Specific Value (16 characters) | Acuvim IIR/IIW     | String    | R               | 8                   |
| C37CH-C383H                  | 50044-50051 | Version        | Manufacturer Specific Value (16 characters) | H: 2.31<br>S: 3.60 | String    | R               | 8                   |
| C384H-C393H                  | 50052-50067 | Serial Numsber | Manufacturer Specific Value (32 characters) |                    | String    | R               | 16                  |
| C394H                        | 50068       | Device Address | Modbus Device Address                       |                    | Uint16    | R               | 1                   |

## Acuvim II Series Power Meter

| SunSpec: 03H Read, 10H Write |            |                              |   |         |           |                 |                     |
|------------------------------|------------|------------------------------|---|---------|-----------|-----------------|---------------------|
| Address(H)                   | Address(D) | Parameters                   | Range   | Default | Data Type | Access Property | Number of Registers |
| C395H                        | 50069      | ID                           | Meter Configuration:<br>Single Phase (AN or AB):<br>201<br>Split Single Phase (ABN):<br>202<br>WYE-Three Phase (ABCN):<br>203<br>Delta Three Phase (ABC): 204 |         | Uint16    | R               | 1                   |
| C396H                        | 50070      | Length                       | 81  |         | Uint16    | R               | 1                   |
| C397H                        | 50071      | Current: Amps(Average)       | 0~32767 A   |         | Int16     | R               | 1                   |
| C398H                        | 50072      | Current: Phase A             | 0~32767 A   |         | Int16     | R               | 1                   |
| C399H                        | 50073      | Current: Phase B             | 0~32767 A   |         | Int16     | R               | 1                   |
| C39AH                        | 50074      | Current: Phase C             | 0~32767 A   |         | Int16     | R               | 1                   |
| C39BH                        | 50075      | Current SunSpec Scale Factor | 0~32767 A   |         | sunssf    | R               | 1                   |
| C39CH                        | 50076      | Voltage: Average Phase       | 3~2 (used an exponent of a power of 10)   |         | int16     | R               | 1                   |
| C39DH                        | 50077      | Voltage: Phase A             | 0~9999 V  |         | int16     | R               | 1                   |
| C39EH                        | 50078      | Voltage: Phase B             | 0~9999 V  |         | int16     | R               | 1                   |
| C39FH                        | 50079      | Voltage: Phase C             | 0~9999 V  |         | int16     | R               | 1                   |
| C3A0H                        | 50080      | Voltage: Line-Line Average   | 0~9999 V  |         | int16     | R               | 1                   |
| C3A1H                        | 50081      | Voltage: Line AB             | 0~9999 V  |         | int16     | R               | 1                   |
| C3A2H                        | 50082      | Voltage: Line BC             | 0~9999V   |         | int16     | R               | 1                   |
| C3A3H                        | 50083      | Voltage: Line CA             | 0~9999 V  |         | int16     | R               | 1                   |
| C3A4H                        | 50084      | Voltage Scale Factor         | 2~4(used as an exponent of a power of 10)   |         | sunssf    | R               | 1                   |
| C3A5H                        | 50085      | Frequency                    | 45-65Hz   |         | int16     | R               | 1                   |

| SunSpec: 03H Read, 10H Write |            |                             |   |         |           |                 |                     |
|------------------------------|------------|-----------------------------|---|---------|-----------|-----------------|---------------------|
| Address(H)                   | Address(D) | Parameters                  | Range                                     | Default | Data Type | Access Property | Number of Registers |
| C3A6H                        | 50086      | Frequency Scale Factor      | 2(used as an exponent of a power of 10)   |         | sunssf    | R               | 1                   |
| C3A7H                        | 50087      | Total Real Power            | 32768~32767 W                             |         | int16     | R               | 1                   |
| C3A8H                        | 50088      | Real Power: Phase A Watts   | 32768~32767 W                             |         | int16     | R               | 1                   |
| C3A9H                        | 50089      | Real Power: Phase B Watts   | 32768~32767 W                             |         | int16     | R               | 1                   |
| C3AAH                        | 50090      | Real Power: Phase C Watts   | 32768~32767                               |         | int16     | R               | 1                   |
| C3ABH                        | 50091      | Real Power Scale Factor     | 1~8(used as an exponent of a power of 10) |         | sunssf    | R               | 1                   |
| C3ACH                        | 50092      | Total Apparent Power        | 0~32367 VA                                |         | int16     | R               | 1                   |
| C3ADH                        | 50093      | Apparent Power: Phase A VA  | 0~32367 VA                                |         | int16     | R               | 1                   |
| C3AEH                        | 50094      | Apparent Power: Phase B VA  | 0~32367 VA                                |         | int16     | R               | 1                   |
| C3AFH                        | 50095      | Apparent Power: Phase C VA  | 0~32767 VA                                |         | int16     | R               | 1                   |
| C3B0H                        | 50096      | Apparent Power Scale Factor | 1~8(used as an exponent of a power of 10) |         | sunssf    | R               | 1                   |
| C3B1H                        | 50097      | Total Reactive Power        | 32768~32767 var                           |         | int16     | R               | 1                   |
| C3B2H                        | 50098      | Reactive Power: Phase A var | 32768~32767 var                           |         | int16     | R               | 1                   |
| C3B3H                        | 50099      | Reactive Power: Phase B var | 3278~32767 var                            |         | int16     | R               | 1                   |
| C3B4H                        | 50100      | Reactive Power: Phase C var | 32768~32767 var                           |         | int16     | R               | 1                   |
| C3B5H                        | 50101      | Reactive Power Scale Factor | 1~8(used as an exponent of a power of 10) |         | sunssf    | R               | 1                   |
| C3B6H                        | 50102      | Power Factor                | 1000~1000                                 |         | int16     | R               | 1                   |
| C3B7H                        | 50103      | Power Factor: Phase A PF    | 1000~1000                                 |         | int16     | R               | 1                   |
| C3B8H                        | 50104      | Power Factor: Phase B PF    | 1000~1000                                 |         | int16     | R               | 1                   |
| C3B9H                        | 50105      | Power Factor: Phase C PF    | 1000~1000                                 |         | int16     | R               | 1                   |

## Acuvim II Series Power Meter

| SunSpec: 03H Read, 10H Write |             |                                 |   |         |           |                 |                     |
|------------------------------|-------------|---------------------------------|---|---------|-----------|-----------------|---------------------|
| Address(H)                   | Address(D)  | Parameters                      | Range                                     | Default | Data Type | Access Property | Number of Registers |
| C3BAH                        | 50106       | Power Factor Scale Factor       | 3(used an exponent of a power of 10)      |         | sunssf    | R               | 1                   |
| C3BBH-C3BCH                  | 50107-50108 | Total Real Energy: Export       | 0~999999999 Wh                            |         | int32     | R/W             | 2                   |
| C3BDH-C3BEH                  | 50109-50110 | Export Real Energy: Phase A     | 0~999999999 Wh                            |         | int32     | R/W             | 2                   |
| C3BFH-C3C0H                  | 50111-50112 | Export Real Energy: Phase B     | 0~999999999 Wh                            |         | int32     | R/W             | 2                   |
| C3C1H-C3C2H                  | 50113-50114 | Export Real Energy: Phase C     | 0~999999999 Wh                            |         | int32     | R/W             | 2                   |
| C3C3H-C3C4H                  | 50115-50116 | Total Real Energy: Import       | 0~999999999 Wh                            |         | int32     | R/W             | 2                   |
| C3C5H-C3C6H                  | 50117-50118 | Import Real Energy: Phase A     | 0~999999999 Wh                            |         | int32     | R/W             | 2                   |
| C3C7H-C3C8H                  | 50119-50120 | Import Real Energy: Phase B     | 0~999999999 Wh                            |         | int32     | R/W             | 2                   |
| C3C9H-C3CAH                  | 50121-50122 | Import Real Energy: Phase C     | 0~999999999 Wh                            |         | int32     | R/W             | 2                   |
| C3CBH                        | 50123       | Real Energy Scale Factor        | 0,2(used as an exponent of a power of 10) |         | sunssf    | R               | 1                   |
| C3CCH-C3CDH                  | 50124-50125 | Total Apparent Energy           | 0~999999999 VAh                           |         | int32     | R/W             | 2                   |
| C3CEH-C3CFH                  | 50126-50127 | Apparent Energy: Phase A        | 0~999999999 VAh                           |         | int32     | R/W             | 2                   |
| C3D0H-C3D1H                  | 50128-50129 | Apparent Energy: Phase B        | 0~999999999 VAh                           |         | int32     | R/W             | 2                   |
| C3D2H-C3D3H                  | 50130-50131 | Apparent Energy: Phase C        | 0~999999999 VAh                           |         | int32     | R/W             | 2                   |
| C3D4H                        | 50132       | Apparent Energy Scale Factor    | 0,2(used as an exponent of a power of 10) |         | sunssf    | R               | 1                   |
| C3D5H-C3D6H                  | 50133-50134 | Total Reactive Energy: Export   | 0~999999999 varh                          |         | int32     | R/W             | 2                   |
| C3D7H-C3D8H                  | 50135-50136 | Export Reactive Energy: Phase A | 0~999999999 varh                          |         | int32     | R/W             | 2                   |
| C3D9H-C3DAH                  | 50137-50138 | Export Reactive Energy: Phase B | 0~999999999 varh                          |         | int32     | R/W             | 2                   |
| C3DBH-C3DCH                  | 50139-50140 | Export Reactive Energy: Phase C | 0~999999999 varh                          |         | int32     | R/W             | 2                   |

| SunSpec: 03H Read, 10H Write |             |                                 |   |         |           |                 |                     |
|------------------------------|-------------|---------------------------------|---|---------|-----------|-----------------|---------------------|
| Address(H)                   | Address(D)  | Parameters                      | Range                                     | Default | Data Type | Access Property | Number of Registers |
| C3DDH-C3DEH                  | 50141-50142 | Total Reactive Energy: Import   | 0~999999999 varh                          |         | int32     | R/W             | 2                   |
| C3DFH-C3E0H                  | 50143-50144 | Import Reactive Energy: Phase A | 0~999999999 varh                          |         | int32     | R/W             | 2                   |
| C3E1H-C3E2H                  | 50145-50146 | Import Reactive Energy: Phase B | 0~999999999 varh                          |         | int32     | R/W             | 2                   |
| C3E3H-C3E4H                  | 50174-50148 | Import Reactive Energy: Phase C | 0~999999999 varh                          |         | int32     | R/W             | 2                   |
| C3E5H                        | 50149       | Reactive Power Scale Factor     | 0,2(used as an exponent of a power of 10) |         | sunssf    | R               | 1                   |
| C3E6H-C3E7H                  | 50150-50151 | Meter Event Flags               | 0   |         | Binary    | R               | 2                   |
| C3E8H                        | 50152       | SunSpec_end_ID: Sunspec         | FFFF                                      |         | int16     |                 | 1                   |
| C3E9H                        | 50153       | SunSpec_end_ID: Sunspec         | 0   |         | int16     |                 | 1                   |

## Chapter 6: Communication Part II

### 6.3.17 Over/Under Alarm Setting

This setting consists of alarm settings and single channel alarm settings. Alarm settings contain settings for all variables. There are 16 groups of records with the same format.

Function code: 03H for reading, 10H for writing.

Please refer to Chapter 4 for more details.

#### Alarm Settings

Table 6-54

| Alarm Settings: 03H Read, 10H Write |            |                                   |   |           |                 |
|-------------------------------------|------------|-----------------------------------|---|-----------|-----------------|
| Address(H)                          | Address(D) | Parameters                        | Range   | Data Type | Access Property |
| 1046H                               | 4166       | Alarm enable                      | 0: Disable, 1: Enable   | Word      | R/W             |
| 1047H                               | 4167       | Alarm flash enable                | 0: Disable, 1: Enable   | Word      | R/W             |
| 1048H                               | 4168       | Alarm channel enable              | 0~65535<br>Bit0: Channel 1<br>1: Enable<br>0: Disable<br>Bit1: Channel 2 .. Bit15: Channel 16                       | Word      | R/W             |
| 1049H                               | 4169       | Logic "And" between alarm setting | 0~255<br>Bit0: First logic switch<br>Bit1: Second logic switch .. Bit7:<br>Eighth logic switch                      | Word      | R/W             |
| 104AH                               | 4170       | Alarming output to DO1 setting    | 0~65535<br>Bit0: Channel 1 output<br>1: Enable, 0: Disable<br>Bit1: Channel 2 output .. Bit15:<br>Channel 16 output | Word      | R/W             |
| 104BH                               | 4171       | Alarming output to DO3 setting    | 0~65535<br>Bit0: Channel 1 output<br>1: Enable, 0: Disable<br>Bit1: Channel 2 output .. Bit15:<br>Channel 16 output | Word      | R/W             |

| Alarm Settings: 03H Read, 10H Write |            |                                |   |           |                 |
|-------------------------------------|------------|--------------------------------|---|-----------|-----------------|
| Address(H)                          | Address(D) | Parameters                     | Range   | Data Type | Access Property |
| 104CH                               | 4172       | Alarming output to DO3 setting | 0~65535<br>Bit0: Channel 1 output<br>1: Enable, 0: Disable<br>Bit1: Channel 2 output .. Bit15:<br>Channel 16 output | Word      | R/W             |
| 104DH                               | 4173       | Alarming output to DO4 setting | 0~65535<br>Bit0: Channel 1 output<br>1: Enable, 0: Disable<br>Bit1: Channel 2 output .. Bit15:<br>Channel 16 output | Word      | R/W             |

Single Channel Alarm Settings

Table 6-55

| Single Channel Alarm Settings: 03H Read, 10H Write |            |                            |  |           |                 |
|--|------------|----------------------------|--|-----------|-----------------|
| Address(H)   | Address(D) | Parameters                 | Range  | Data Type | Access Property |
| 104EH  | 4174       | 1st group: parameter code  | 0~79   | Word      | R/W             |
| 104FH  | 4175       | 1st group: comparison mode | 1: Greater than<br>2: Equal to<br>3: Less than | Word      | R/W             |
| 1050H  | 4176       | 1st group: setpoint value  | Related with parameters                        | Word      | R/W             |
| 1051H  | 4177       | 1st group: delay           | 0~3000 (*10ms)                                 | Word      | R/W             |
| 1052H  | 4178       | 1st group: output to relay | 0:none<br>1~8: related relay                   | Word      | R/W             |
| 1053H  | 4179       | 2nd group: parameter code  | 0~79   | Word      | R/W             |
| 1054H  | 4180       | 2nd group: comparison mode | 1: Greater than<br>2: Equal to<br>3: Less than | Word      | R/W             |
| 1055H  | 4181       | 2nd group: setpoint value  | Related with parameters                        | Word      | R/W             |
| 1056H  | 4182       | 2nd group: delay           | 0~3000 (*10ms)                                 | Word      | R/W             |
| 1057H  | 4183       | 2nd group: output to relay | 0:none<br>1~8: related relay                   | Word      | R/W             |

## Acuvim II Series Power Meter

| Single Channel Alarm Settings: 03H Read, 10H Write |            |                            |  |           |                 |
|--|------------|----------------------------|--|-----------|-----------------|
| Address(H)   | Address(D) | Parameters                 | Range  | Data Type | Access Property |
| 1058H  | 4184       | 3rd group: parameter code  | 0~79   | Word      | R/W             |
| 1059H  | 4185       | 3rd group: comparison mode | 1: Greater than<br>2: Equal to<br>3: Less than | Word      | R/W             |
| 105AH  | 4186       | 3rd group: setpoint value  | Related with parameters                        | Word      | R/W             |
| 105BH  | 4187       | 3rd group: delay           | 0~3000 (*10ms)                                 | Word      | R/W             |
| 105CH  | 4188       | 3rd group: output to relay | 0:none<br>1~8: related relay                   | Word      | R/W             |
| 105DH  | 4189       | 4th group: parameter code  | 0~79   | Word      | R/W             |
| 105EH  | 4190       | 4th group: comparison mode | 1: Greater than<br>2: Equal to<br>3: Less than | Word      | R/W             |
| 105FH  | 4191       | 4th group: setpoint value  | Related with parameters                        | Word      | R/W             |
| 1060H  | 4192       | 4th group: delay           | 0~3000 (*10ms)                                 | Word      | R/W             |
| 1061H  | 4193       | 4th group: output to relay | 0:none<br>1~8: related relay                   | Word      | R/W             |
| 1062H  | 4194       | 5th group: parameter code  | 0~79   | Word      | R/W             |
| 1063H  | 4195       | 5th group: comparison mode | 1: Greater than<br>2: Equal to<br>3: Less than | Word      | R/W             |
| 1064H  | 4196       | 5th group: setpoint value  | Related with parameters                        | Word      | R/W             |
| 1065H  | 4197       | 5th group: delay           | 0~3000 (*10ms)                                 | Word      | R/W             |
| 1066H  | 4198       | 5th group: output to relay | 0:none<br>1~8: related relay                   | Word      | R/W             |
| 1067H  | 4199       | 6th group: parameter code  | 0~79   | Word      | R/W             |
| 1068H  | 4200       | 6th group: comparison mode | 1: Greater than<br>2: Equal to<br>3: Less than | Word      | R/W             |
| 1069H  | 4201       | 6th group: setpoint value  | Related with parameters                        | Word      | R/W             |
| 106AH  | 4202       | 6th group: delay           | 0~3000 (*10ms)                                 | Word      | R/W             |

| Single Channel Alarm Settings: 03H Read, 10H Write |            |                             |  |           |                 |
|--|------------|-----------------------------|--|-----------|-----------------|
| Address(H)   | Address(D) | Parameters                  | Range  | Data Type | Access Property |
| 106BH  | 4203       | 6th group: output to relay  | 0:none<br>1~8: related relay                   | Word      | R/W             |
| 106CH  | 4203       | 7th group: parameter code   | 0~79   | Word      | R/W             |
| 106DH  | 4204       | 7th group: comparison mode  | 1: Greater than<br>2: Equal to<br>3: Less than | Word      | R/W             |
| 106EH  | 4205       | 7th group: setpoint value   | Related with parameters                        | Word      | R/W             |
| 106FH  | 4206       | 7th group: delay            | 0~3000 (*10ms)                                 | Word      | R/W             |
| 1070H  | 4207       | 7th group: output to relay  | 0:none<br>1~8: related relay                   | Word      | R/W             |
| 1071H  | 4208       | 8th group: parameter code   | 0~79   | Word      | R/W             |
| 1072H  | 4209       | 8th group: comparison mode  | 1: Greater than<br>2: Equal to<br>3: Less than | Word      | R/W             |
| 1073H  | 4210       | 8th group: setpoint value   | Related with parameters                        | Word      | R/W             |
| 1074H  | 4211       | 8th group: delay            | 0~3000 (*10ms)                                 | Word      | R/W             |
| 1075H  | 4212       | 8th group: output to relay  | 0:none<br>1~8: related relay                   | Word      | R/W             |
| 1076H  | 4213       | 9th group: parameter code   | 0~79   | Word      | R/W             |
| 1078H  | 4214       | 9th group: comparison mode  | 1: Greater than<br>2: Equal to<br>3: Less than | Word      | R/W             |
| 1079H  | 4215       | 9th group: setpoint value   | Related with parameters                        | Word      | R/W             |
| 107AH  | 4216       | 9th group: delay            | 0~3000 (*10ms)                                 | Word      | R/W             |
| 107BH  | 4217       | 9th group: output to relay  | 0:none<br>1~8: related relay                   | Word      | R/W             |
| 107CH  | 4218       | 10th group: parameter code  | 0~79   | Word      | R/W             |
| 107DH  | 4219       | 10th group: comparison mode | 1: Greater than<br>2: Equal to<br>3: Less than | Word      | R/W             |
| 107EH  | 4220       | 10th group: setpoint value  | Related with parameters                        | Word      | R/W             |

## Acuvim II Series Power Meter

| Single Channel Alarm Settings: 03H Read, 10H Write |            |                             |  |           |                 |
|--|------------|-----------------------------|--|-----------|-----------------|
| Address(H)   | Address(D) | Parameters                  | Range  | Data Type | Access Property |
| 107FH  | 4221       | 10th group: delay           | 0~3000 (*10ms)                                 | Word      | R/W             |
| 1080H  | 4222       | 10th group: output to relay | 0:none<br>1~8: related relay                   | Word      | R/W             |
| 1081H  | 4223       | 11th group: parameter code  | 0~79   | Word      | R/W             |
| 1081H  | 4224       | 11th group: comparison mode | 1: Greater than<br>2: Equal to<br>3: Less than | Word      | R/W             |
| 1082H  | 4225       | 11th group: setpoint value  | Related with parameters                        | Word      | R/W             |
| 1083H  | 4226       | 11th group: delay           | 0~3000 (*10ms)                                 | Word      | R/W             |
| 1084H  | 4227       | 11th group: output to relay | 0:none<br>1~8: related relay                   | Word      | R/W             |
| 1085H  | 4228       | 12th group: parameter code  | 0~79   | Word      | R/W             |
| 1086H  | 4229       | 12th group: comparison mode | 1: Greater than<br>2: Equal to<br>3: Less than | Word      | R/W             |
| 1087H  | 4230       | 12th group: setpoint value  | Related with parameters                        | Word      | R/W             |
| 1088H  | 4231       | 12th group: delay           | 0~3000 (*10ms)                                 | Word      | R/W             |
| 1089H  | 4232       | 12th group: output to relay | 0:none<br>1~8: related relay                   | Word      | R/W             |
| 108AH  | 4233       | 13th group: parameter code  | 0~79   | Word      | R/W             |
| 108BH  | 4234       | 13th group: comparison mode | 1: Greater than<br>2: Equal to<br>3: Less than | Word      | R/W             |
| 108CH  | 4235       | 13th group: setpoint value  | Related with parameters                        | Word      | R/W             |
| 108DH  | 4236       | 13th group: delay           | 0~3000 (*10ms)                                 | Word      | R/W             |
| 108EH  | 4237       | 13th group: output to relay | 0:none<br>1~8: related relay                   | Word      | R/W             |
| 108FH  | 4238       | 14th group: parameter code  | 0~79   | Word      | R/W             |
| 1090H  | 4239       | 14th group: comparison mode | 1: Greater than<br>2: Equal to<br>3: Less than | Word      | R/W             |

| Single Channel Alarm Settings: 03H Read, 10H Write |            |                             |  |           |                 |
|--|------------|-----------------------------|--|-----------|-----------------|
| Address(H)   | Address(D) | Parameters                  | Range  | Data Type | Access Property |
| 1091H  | 4240       | 14th group: setpoint value  | Related with parameters                        | Word      | R/W             |
| 1092H  | 4241       | 14th group: delay           | 0~3000 (*10ms)                                 | Word      | R/W             |
| 1093H  | 4242       | 14th group: output to relay | 0:none<br>1~8: related relay                   | Word      | R/W             |
| 1094H  | 4243       | 15th group: parameter code  | 0~79   | Word      | R/W             |
| 1095H  | 4244       | 15th group: comparison mode | 1: Greater than<br>2: Equal to<br>3: Less than | Word      | R/W             |
| 1096H  | 4245       | 15th group: setpoint value  | Related with parameters                        | Word      | R/W             |
| 1097H  | 4246       | 15th group: delay           | 0~3000 (*10ms)                                 | Word      | R/W             |
| 1098H  | 4247       | 15th group: output to relay | 0:none<br>1~8: related relay                   | Word      | R/W             |
| 1099H  | 4248       | 16th group: parameter code  | 0~79   | Word      | R/W             |
| 109AH  | 4249       | 16th group: comparison mode | 1: Greater than<br>2: Equal to<br>3: Less than | Word      | R/W             |
| 109BH  | 4250       | 16th group: setpoint value  | Related with parameters                        | Word      | R/W             |
| 109CH  | 4251       | 16th group: delay           | 0~3000 (*10ms)                                 | Word      | R/W             |
| 109DH  | 4252       | 16th group: output to relay | 0:none<br>1~8: related relay                   | Word      | R/W             |

**Alarming Parameter Code Table**

Table 6-56

| Alarming Parameter Code Table |                    |               |                       |               |                      |
|-------------------------------|--------------------|---------------|-----------------------|---------------|----------------------|
| Setting Value                 | Alarming Object    | Setting Value | Alarming Object       | Setting Value | Alarming Object      |
| 0                             | Frequency          | 1             | Va                    | 2             | Vb                   |
| 3                             | Vc                 | 4             | Average phase voltage | 5             | Uab                  |
| 6                             | Ubc                | 7             | Uca                   | 8             | Average line voltage |
| 9                             | Current of phase A | 10            | Current of phase B    | 11            | Current of phase C   |
| 12                            | Average current    | 13            | Neutral current       | 14            | Power of phase A     |

## Acuvim II Series Power Meter

| Alarming Parameter Code Table |                                |               |                                |               |                              |
|-------------------------------|--------------------------------|---------------|--------------------------------|---------------|------------------------------|
| Setting Value                 | Alarming Object                | Setting Value | Alarming Object                | Setting Value | Alarming Object              |
| 15                            | Power of phase B               | 16            | Power of phase C               | 17            | Power of all                 |
| 18                            | Reactive power of phase A      | 19            | Reactive power of phase B      | 20            | Reactive power of phase C    |
| 21                            | Reactive power of all          | 22            | Apparent power of phase A      | 23            | Apparent power of phase B    |
| 24                            | Apparent power of phase C      | 25            | Apparent power of all          | 26            | PF of A                      |
| 27                            | PF of B                        | 28            | PF of C                        | 29            | PF                           |
| 30                            | Voltage unbalance factor Uunbl | 31            | Current unbalance factor Iunbl | 32            | Load characteristic (R/C/L)  |
| 33                            | THDV1(V1 or V12)               | 34            | THDV2(V2 or V31)               | 35            | THDV3(V3 or V23)             |
| 36                            | Average THDV                   | 37            | THDI1                          | 38            | THDI2                        |
| 39                            | THDI3                          | 40            | Average THDI                   | 41            | AI1 sampling value           |
| 42                            | AI2 sampling value             | 43            | AI3 sampling value             | 44            | AI4 sampling value           |
| 45                            | Active power demand of all     | 46            | Reactive power demand of all   | 47            | Apparent power demand of all |
| 48                            | Current demand of phase A      | 49            | Current demand of phase B      | 50            | Current demand of phase C    |

### NOTE:

- When reversed phase sequence (51) is selected, whether the value of comparison mode or setpoint value is set or not will not affect alarm result and the angle of  $U_b$  to  $U_a$  will be recorded.
- When DI (52~79) is selected, whether the value of comparison mode is set or not will not affect alarm result as long as the setpoint value is set to 1, 2, or 3.
  - 1: Stands for DI alarm is ON, recovery is OFF.
  - 2: Stands for DI alarm is OFF, recovery is ON.
  - 3: Stands for DI alarm is OFF, recovery is ON, and present DI status is recorded.

There are 16 groups of records with the same format. Please refer to Chapter 4 for more details.

**Table 6-57**

| Alarming Group Records: 03H Read |            |                                    |         |           |                 |
|----------------------------------|------------|------------------------------------|---------|-----------|-----------------|
| Address(H)                       | Address(D) | Parameters                         | Range   | Data Type | Access Property |
| 42A9H                            | 17065      | 1st group: alarming status         | 0-65535 | Word      | R               |
| 42AAH                            | 17066      | 1st group: alarming parameter code | 0-79    | Word      | R               |

| Alarming Group Records: 03H Read |             |  |                             |           |                 |
|----------------------------------|-------------|--|-----------------------------|-----------|-----------------|
| Address(H)                       | Address(D)  | Parameters                                 | Range                       | Data Type | Access Property |
| 42ABH                            | 17067       | 1st group: over/under limit or reset value | Related to parameter chosen | Word      | R               |
| 42ACH~42B2H                      | 17068-17074 | 1st group: Timestamp: yyyy:mm:dd:hh:ss:ms  |                             | Word      | R               |
| 42B3H                            | 17075       | 2nd group: alarming status                 | 0-65535                     | Word      | R               |
| 42B4H                            | 17076       | 2nd group: alarming parameter code         | 0-79                        | Word      | R               |
| 42B5H                            | 17077       | 2nd group: over/under limit or reset value | Related to parameter chosen | Word      | R               |
| 42B6H-42BCH                      | 17078-17084 | 2nd group: Timestamp: yyyy:mm:dd:hh:ss:ms  |                             | Word      | R               |
| 42BDH                            | 17085       | 3rd group: alarming status                 | 0-65535                     | Word      | R               |
| 42BEH                            | 17086       | 3rd group: alarming parameter code         | 0-79                        | Word      | R               |
| 42BFH                            | 17087       | 3rd group: over/under limit or reset value | Related to parameter chosen | Word      | R               |
| 42C0H-42C6H                      | 17088-17094 | 3rd group: Timestamp: yyyy:mm:dd:hh:ss:ms  |                             | Word      | R               |
| 42C7H                            | 17095       | 4th group: alarming status                 | 0-65535                     | Word      | R               |
| 42C8H                            | 17096       | 4th group: alarming parameter code         | 0-79                        | Word      | R               |
| 42C9H                            | 17097       | 4th group: over/under limit or reset value | Related to parameter chosen | Word      | R               |
| 42CAH-42D0H                      | 17098-17104 | 4th group: Timestamp: yyyy:mm:dd:hh:ss:ms  |                             | Word      | R               |
| 42D1H                            | 17105       | 5th group: alarming status                 | 0-65535                     | Word      | R               |
| 42D2H                            | 17106       | 5th group: alarming parameter code         | 0-79                        | Word      | R               |
| 42D3H                            | 17107       | 5th group: over/under limit or reset value | Related to parameter chosen | Word      | R               |
| 42D4H-42DAH                      | 17108-17114 | 5th group: Timestamp: yyyy:mm:dd:hh:ss:ms  |                             | Word      | R               |
| 42DBH                            | 17115       | 6th group: alarming status                 | 0-65535                     | Word      | R               |
| 42DCH                            | 170116      | 6th group: alarming parameter code         | 0-79                        | Word      | R               |
| 42DDH                            | 17117       | 6th group: over/under limit or reset value | Related to parameter chosen | Word      | R               |
| 42DEH-42E4H                      | 17118-17124 | 6th group: Timestamp: yyyy:mm:dd:hh:ss:ms  |                             | Word      | R               |
| 42E5H                            | 17125       | 7th group: alarming status                 | 0-65535                     | Word      | R               |
| 42E6H                            | 17126       | 7th group: alarming parameter code         | 0-79                        | Word      | R               |
| 42E7H                            | 17127       | 7th group: over/under limit or reset value | Related to parameter chosen | Word      | R               |

## Acuvim II Series Power Meter

| Alarming Group Records: 03H Read |             |  |                             |           |                 |
|----------------------------------|-------------|--|-----------------------------|-----------|-----------------|
| Address(H)                       | Address(D)  | Parameters                                   | Range                       | Data Type | Access Property |
| 42E8H-42EEH                      | 17128-17134 | 7th group: Timestamp:<br>yyy:mm:dd:hh:ss:ms  |                             | Word      | R               |
| 42EFH                            | 17135       | 8th group: alarming status                   | 0-65535                     | Word      | R               |
| 42F0H                            | 17136       | 8th group: alarming parameter code           | 0-79                        | Word      | R               |
| 42F1H                            | 17137       | 8th group: over/under limit or reset value   | Related to parameter chosen | Word      | R               |
| 42F2H-42F8H                      | 17138-17144 | 8th group: Timestamp:<br>yyy:mm:dd:hh:ss:ms  |                             | Word      | R               |
| 42F9H                            | 17145       | 9th group: alarming status                   | 0-65535                     | Word      | R               |
| 42FAH                            | 17146       | 9th group: alarming parameter code           | 0-79                        | Word      | R               |
| 42FBH                            | 17147       | 9th group: over/under limit or reset value   | Related to parameter chosen | Word      | R               |
| 42FCH-4302H                      | 17148-17154 | 9th group: Timestamp:<br>yyy:mm:dd:hh:ss:ms  |                             | Word      | R               |
| 4303H                            | 17155       | 10th group: alarming status                  | 0-65535                     | Word      | R               |
| 4304H                            | 17156       | 10th group: alarming parameter code          | 0-79                        | Word      | R               |
| 4305H                            | 17157       | 10th group: over/under limit or reset value  | Related to parameter chosen | Word      | R               |
| 4306H-430CH                      | 17158-17164 | 10th group: Timestamp:<br>yyy:mm:dd:hh:ss:ms |                             | Word      | R               |
| 430DH                            | 17165       | 11th group: alarming status                  | 0-65535                     | Word      | R               |
| 430EH                            | 17166       | 11th group: alarming parameter code          | 0-79                        | Word      | R               |
| 430FH                            | 17167       | 11th group: over/under limit or reset value  | Related to parameter chosen | Word      | R               |
| 4310H-4316H                      | 17168-17174 | 11th group: Timestamp:<br>yyy:mm:dd:hh:ss:ms |                             | Word      | R               |
| 4317H                            | 17175       | 12th group: alarming status                  | 0-65535                     | Word      | R               |
| 4318H                            | 17176       | 12th group: alarming parameter code          | 0-79                        | Word      | R               |
| 4319H                            | 17177       | 12th group: over/under limit or reset value  | Related to parameter chosen | Word      | R               |
| 431AH-4320H                      | 17178-17184 | 12th group: Timestamp:<br>yyy:mm:dd:hh:ss:ms |                             | Word      | R               |
| 4321H                            | 17185       | 13th group: alarming status                  | 0-65535                     | Word      | R               |
| 4322H                            | 17186       | 13th group: alarming parameter code          | 0-79                        | Word      | R               |
| 4323H                            | 17187       | 13th group: over/under limit or reset value  | Related to parameter chosen | Word      | R               |

| Alarming Group Records: 03H Read |             |  |                             |           |                 |
|----------------------------------|-------------|--|-----------------------------|-----------|-----------------|
| Address(H)                       | Address(D)  | Parameters                                   | Range                       | Data Type | Access Property |
| 4324H-432AH                      | 17188-17194 | 13th group: Timestamp:<br>yyy:mm:dd:hh:ss:ms |                             | Word      | R               |
| 432BH                            | 17195       | 14th group: alarming status                  | 0-65535                     | Word      | R               |
| 432CH                            | 17196       | 14th group: alarming parameter code          | 0-79                        | Word      | R               |
| 432DH                            | 17197       | 14th group: over/under limit or reset value  | Related to parameter chosen | Word      | R               |
| 432EH-4334H                      | 17198-17204 | 14th group: Timestamp:<br>yyy:mm:dd:hh:ss:ms |                             | Word      | R               |
| 4335H                            | 17205       | 15th group: alarming status                  | 0-65535                     | Word      | R               |
| 4336H                            | 17206       | 15th group: alarming parameter code          | 0-79                        | Word      | R               |
| 4337H                            | 17207       | 15th group: over/under limit or reset value  | Related to parameter chosen | Word      | R               |
| 4338H-433EH                      | 17208-17214 | 15th group: Timestamp:<br>yyy:mm:dd:hh:ss:ms |                             | Word      | R               |
| 433FH                            | 17215       | 16th group: alarming status                  | 0-65535                     | Word      | R               |
| 4340H                            | 17216       | 16th group: alarming parameter code          | 0-79                        | Word      | R               |
| 4341H                            | 17217       | 16th group: over/under limit or reset value  | Related to parameter chosen | Word      | R               |
| 4342H-4348H                      | 17218-17224 | 16th group: Timestamp:<br>yyy:mm:dd:hh:ss:ms |                             | Word      | R               |

### 6.3.18 Data Logging

#### Data Logging Setting

In order to generate historical logs for the selected parameters, users should program the meter so that selected parameters from the corresponding Modbus registers can be copied to the historical log record. Since certain parameters occupy two registers, the programmable settings for the historical logs contain a list of descriptors to supplement this. Each descriptor lists the number of Modbus registers for the specified parameter. By combining these two lists, the historical log record can be interpreted.

For example: Registers 4002H and 4003H are programmed to be recorded by the historical log. Since 2 registers are used, the corresponding descriptor is set as 2. These registers program the log to record "Volts AN".

The historical log programmable settings are comprised of 3 blocks, one for each log. Each

## Acuvim II Series Power Meter

log works in an identical fashion; therefore, only historical log 1 is described here. All register addresses in this section are shown within the address range of historical log 1.

1100H-11DFH (Historical Data Log 1)

11C0H-127FH (Historical Data Log 2)

1280H-133FH (Historical Data Log 3)

Block Size: 192 registers per log (384 bytes)

Data Log Setting's Address Map:

Table 6-58

| Address | 1100H        |               | 1101H        |               |
|---------|--------------|---------------|--------------|---------------|
| Byte    | 0 (low byte) | 1 (high byte) | 2 (low byte) | 3 (high byte) |
| Value   | Sectors      | Registers     | Interval     |               |

**Registers:** The number of registers to log in the record range from {0-117}. The size of the record in memory is  $[12 + (\text{Registers} \times 2)]$ .

**Sectors:** The number of memory sectors allocated to this log, where each sector is 64kb in size. There are 100 sectors available for allocation among the three historical logs, and the valid allocation range is from 0~100 (When the sector is set to 0, this log is disabled).

**Interval:** The data capture interval for historical log records. Valid time interval can be set from 0-1440 minutes. When the interval is set to 0, the log is disabled.

**NOTE:** When sectors or Register or Interval is zero, the log is disabled.

### Register List

**Registers:** 1102H-1176H

**Size:** 1 or 2 register(s) per parameter, 117 available registers per historical log. The register list controls which Modbus registers are recorded in each historical log record. Since many parameters, such as Voltage, Energy, etc., take up more than 1 register, multiple registers are allocated for those parameters.

For example: In order to record "Volts AN" into the historical log, Volts AN's Modbus addresses (4002H and 4003H) are assigned and programmed to the log record list so that information can be stored into the historical log registers.

- Each unused register item should be set to 0000H or FFFFH to indicate no parameters are associated with them.
- The actual size of the record, and the number of items in the register list which are used, is determined by the registers in the header.

- Valid register address ranges that can be recorded in the historical log registers are 4000H-412BH, 4294H-42A8H, 4349H-4398H, 4500H-461BH, 4620H-463DH.

**Item Descriptor List**

**Registers:** 1177H-11B1H

**Size:** 1 byte per item, 117 bytes (59 registers)

While the register list describes what to log, the item descriptor list describes how to interpret that information. Each descriptor describes how many Modbus addresses are used to describe a parameter. Either 1 or 2 addresses will be used for each parameter.

For example: If the first descriptor is 2, and the second descriptor is 1, then the first 2 register items belong to the 1st descriptor, and the 3rd register item belongs to the 2nd descriptor.

**NOTE:** As can be seen from the example above, it is not a 1-to-1 relationship between the register list and the descriptor list. A single descriptor may refer to two register items.

**Logging Time Setting**

If the data logging only records one period data, or only starts from one specific time, the corresponding time and logging mode should be set accordingly for the data log function to work. Modbus address 11B2H is used as the logging mode select. The following describes the different logging modes:

- When register 11B2H is set to 0, the logging mode is set to Mode 1 which starts logging immediately until the memory is full (First In, First Out).
- When register 11B2H is set to 1, the logging mode is set to Mode 2 which starts/ends logging based on the start/end time.
  - The start time is set in registers 11B3H-11B5H (start year, month, day, hour, minute, and second) and the end time is set in registers 11B6H-11B8H (end year, month, day, hour, minute, and second).
- When register 11B2H is set to 2, the logging mode is set to Mode 3 which starts logging at a specific time until the memory is full.
  - Only the start time should be set, only registers 11B4H-11B5H (hour and minute).

**NOTE:** For more details regarding the data logging function, please refer to data logging section of Chapter 4.

**Registers** 11B3H-11B5H (start time)  
11B6H-11B8H (end time)  
**Size** 2 Registers

| Byte  | 0     | 1    | 2    | 3   | 4      | 5      |
|-------|-------|------|------|-----|--------|--------|
| Value | Month | Year | Hour | Day | Second | Minute |

**Log Status Block**

The Log Status Block describes the current status of the log in question.

**Table 6-59**

| Address(H)  | Address(D)  | Parameters             | Range                   | Data Type | Property |
|-------------|-------------|------------------------|-------------------------|-----------|----------|
| 6100H-6101H | 24832-24833 | Max records            | 0-468104                | Dword     | R        |
| 6102H-6103H | 24834-24835 | Used records           | 1-468104                | Dword     | R        |
| 6104H       | 24836       | Record size            | 14-246                  | Word      | R        |
| 6105H       | 24837       | Reserved               |                         | Word      | R        |
| 6106H-6108H | 24838-24840 | First record timestamp |                         | Word      | R        |
| 6109H-610BH | 24841-24843 | Last record timestamp  |                         | Word      | R        |
| 6200H-620BH | 25088-25099 | Data Log 2 status      | Same as the first group |           |          |
| 6300H-630BH | 25344-25355 | Data Log 3 status      | Same as the first group |           |          |

**Max Records:** The maximum number of records the log can hold given the record size and sector allocation.

**Used Records:** The number of records stored in the log. This number will equal the Max Records when the log has filled. This value will be set to 1 when the log is reset.

**Record Size:** The number of bytes in this record, including the timestamp.

The record's format in the meter is: record number (4bytes) + timestamp (6bytes) + [data1~dataN] (2Nbytes) + CRC(2bytes).

**First Record Timestamp:** Timestamp of the oldest record.

**Last Record Timestamp:** Timestamp of the newest record.

**Log Retrieval Block**

The log retrieval block consists of 2 parts: the header and the window. The header is used to verify the data shown within the requested log window. The window is a sliding block of data that can be used to access any record in the specified log.

Registers 6000H-6003H

Size 4 Registers

**Table 6-60**

| Address(H) | Address(D) | Parameters | Format   | Property |
|------------|------------|------------|----------|----------|
| 6000H      | 24576      | Log type   | Nnnnnnnn | R/W      |
|            |            |            | ssssssss |          |

| Address(H)  | Address(D)  | Parameters    | Format   | Property |
|-------------|-------------|---------------|----------|----------|
| 6001H       | 24577       | Record number | Nnnnnnnn | R/W      |
|             |             | Status        | wwwwwwww |          |
| 6002H~6003H | 24578~24579 | Offset        |          | R/W      |
| 6004H~607EH | 24580~24702 | Window        |          | R        |

**Log type:** The log to be retrieved. Write this value to set which log is being retrieved.

- 0 - Historical Log 1
- 1 - Historical Log 2
- 2 - Historical Log 3

**Records Number:** The number of records that fit within a window. This value is settable, and any number less than a full window may be used. This number tells the retrieving program how many records to expect to be fetched in the window. (Record number x Record Size) = bytes used in the window. This value should be  $((123 \times 2) / \text{Record Size})$ , rounded down. The greater the number, the faster the retrieval speed.

For example, with a record size of 50, the Records number =  $((123 \times 2) / 50) = 4.92 \approx 4$ .

**Status:** The status of the current window. Since the time to prepare a window may exceed an acceptable Modbus delay (1 second), this acts as a ready status flag to notify when the window is ready for retrieval. When this value indicates that the window is not ready, the data in the window should be ignored.

**Window Status** is Read-only, any writes are ignored.

This value also indicates the memory erasing status when setting the date logging settings.

**BH Window** is Ready

**FFH Window** is Not Ready

**AAH memory** is erasing

**BBH memory erasing** is finished

**CXH register list** is set error

**X:bit0 1**, register list is set error in datalogging 1;

**bit1 1**, register list is set error in datalogging 2;

**bit2 1**, register list is set error in datalogging 3.

For example **0xC6H**, register lists are error in datalogging 2 and 3

**Offset:** The offset of the record number of the first record in the data window and the record number of the "first record timestamp". Setting this value controls which records will be available

## Acuvim II Series Power Meter

---

in the data window. When the log is retrieved, the first (oldest) record is "latched." This means that offset 0 will always point to the oldest record at the time of latching.

**Window:** The actual data of the records, arranged according to the above settings.

**NOTE:** If the logging timer is disabled, the first recording sector will be erased when the log is full. Therefore, user should not read the whole log when the used record number is near to the max record number. Under this condition, user should read the "Used Records" field and compare it to the previous "Used Records" field from the last reading before retrieving the information and reading the window.

If the current "Used Records" field is greater than the "Used Records" field from the last reading and if the "Offset" field is less than the difference between the current and previous "Used Records" field, the first sector has been erased and the difference between the "Used Records" field should be subtracted from the recording number. If the "Offset" field is greater than the difference between the current and previous "Used Records" field, the "Offset" number should be subtracted from the recording number.

To avoid this situation, user should read the log before it is almost full.

**For example:** Data logging 1 has 3 sectors, each has 448 records, and the total records are 1344. If you press the "Read All" button when the "Used Records" number is at 1340, and if the first sector is erased before the information is transferred to the computer, the data stored in this sector is erased permanently and cannot be retrieved. If the records from the first sector can be retrieved before it gets erased, the new value of "Offset" will equal to the original "Offset" field minus the value of the difference between the current and previous "Used Records" field.

### Data logging operation examples

The following example illustrates a data logging operation. The example makes the following assumptions:

- The log is Historical Log 1.
- The log contains VAN, VBN, VCN (12 bytes), the interval is 1min, the sectors is 10, the registers is 6, the logging timer function is disabled.
- Retrieval is starting at record offset 0 (oldest record). 283
- No new records are recorded to the log during the log retrieval process.

#### a) Data logging settings

Now set the data log 1 according to the assumptions:

1. Set the data log with VAN, VBN, VCN. Here we should set their Modbus address

0x4002,0x4003,0x4004,0x4005,0x4006 and 0x4007 to 0x1102, 0x1103, 0x1104, 0x1105, 0x1106 and 0x1107. And the descriptor is 2, so set the 0x0202 and 0x0200 to 0x1177 and 0x1178.

2. The register is 6 and sector is 10, so we set 0x060A to 0x1100.
3. The interval is 1min, so set the 0x0001 to 0x1101.
4. The logging timer function is disabled, so set the 0 to 0x11B9.

#### b) Log Retrieval Procedure

The following procedure documents how to retrieve a single log from the oldest record to the newest record.

1. Compute the number of records per window, as follows:
  - $\text{RecordsPerWindow} = (246 \setminus \text{RecordSiz}) = 246 \setminus 24 = 10$
2. Write the Records per window and Record offset, in this example set the 0x0A0B and 0x0000 to 0x6001d and 0x6002. This step tells the meter what data to return in the window.
3. Read the record window status from 0x6001.
  - If the Window Status is 0xFF, go to step 2.
  - If the Window Status is 0x0B, read the data window.
4. Read the data window and compute next Expected Record offset.
  - Compute the next expected record offset by adding Records Per Window and go to step 2.
  - If there are no remaining records after the current record window, stop reading.

### 6.3.19 Time-of-Use

#### Data Address of TOU Energy

The data address saves the parameter of energy, which includes Data address of last month TOU energy, Data address of current month TOU energy, Data address of TOU parameter setting and Data address of TOU default parameter. Except for the data address of TOU default parameter, the data address is read with 03 codes, preset with 16 code.

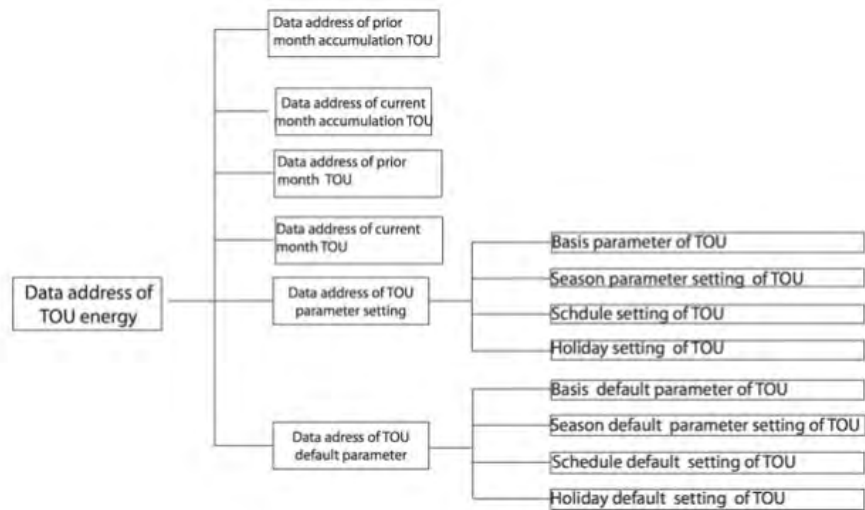

Fig 6-1 Division plan of TOU energy

Table 6-61

| Address(H)                                   | Address(D)  | Parameters     | Range       | Data Type | Type of Access |
|--|-------------|----------------|-------------|-----------|----------------|
| <b>Current month accumulation TOU energy</b> |             |                |             |           |                |
| 7200H~7201H                                  | 29184~29185 | Ep_imp (sharp) | 0~999999999 | Dword     | R/W            |
| 7202H~7203H                                  | 29186~29187 | Ep_exp (sharp) | 0~999999999 | Dword     | R/W            |
| 7204H~7205H                                  | 29188~29189 | Eq_imp (sharp) | 0~999999999 | Dword     | R/W            |
| 7206H~7207H                                  | 29190~29191 | Eq_exp (sharp) | 0~999999999 | Dword     | R/W            |
| 7208H~7209H                                  | 29192~29193 | Es (sharp)     | 0~999999999 | Dword     | R/W            |
| 720AH~720BH                                  | 29194~29195 | Ep_imp (peak)  | 0~999999999 | Dword     | R/W            |
| 720CH~720DH                                  | 29196~29197 | Ep_exp (peak)  | 0~999999999 | Dword     | R/W            |
| 720EH~720FH                                  | 29198~29199 | Eq_imp (peak)  | 0~999999999 | Dword     | R/W            |

| Address(H)                                   | Address(D)  | Parameters      | Range       | Data Type | Type of Access |
|--|-------------|-----------------|-------------|-----------|----------------|
| 7210H-7211H                                  | 29200~29201 | Eq_exp (peak)   | 0~999999999 | Dword     | R/W            |
| 7212H-7213H                                  | 29202~29203 | Es (peak)       | 0~999999999 | Dword     | R/W            |
| 7214H-7215H                                  | 29204~29205 | Ep_imp (valley) | 0~999999999 | Dword     | R/W            |
| 7216H-7217H                                  | 29206~29207 | Ep_exp (valley) | 0~999999999 | Dword     | R/W            |
| 7218H-7219H                                  | 29208~29209 | Eq_imp (valley) | 0~999999999 | Dword     | R/W            |
| 721AH-721BH                                  | 29210~29211 | Eq_exp (valley) | 0~999999999 | Dword     | R/W            |
| 721CH-721DH                                  | 29212~29213 | Es (valley)     | 0~999999999 | Dword     | R/W            |
| 721EH-721FH                                  | 29214~29215 | Ep_imp (normal) | 0~999999999 | Dword     | R/W            |
| 7220H-7221H                                  | 29216~29217 | Ep_exp (normal) | 0~999999999 | Dword     | R/W            |
| 7222H-7223H                                  | 29218~29219 | Eq_imp (normal) | 0~999999999 | Dword     | R/W            |
| 7224H-7225H                                  | 29220~29221 | Eq_exp (normal) | 0~999999999 | Dword     | R/W            |
| 7226H-7227H                                  | 29222~29223 | Es (normal)     | 0~999999999 | Dword     | R/W            |
| 7228H-7229H                                  | 29224~29225 | Ep_imp (sum)    | 0~999999999 | Dword     | R/W            |
| 722AH-722BH                                  | 29226~29227 | Ep_exp (sum)    | 0~999999999 | Dword     | R/W            |
| 722CH-722DH                                  | 29228~29229 | Eq_imp (sum)    | 0~999999999 | Dword     | R/W            |
| 722EH-722FH                                  | 29230~29231 | Eq_exp (sum)    | 0~999999999 | Dword     | R/W            |
| 7230H-7231H                                  | 29232~29233 | Es (sum)        | 0~999999999 | Dword     | R/W            |
| <b>Current month accumulation TOU energy</b> |             |                 |             |           |                |
| 7232H-7233H                                  | 29234~29235 | Ep_imp (sharp)  | 0~999999999 | Dword     | R/W            |
| 7234H-7235H                                  | 29236~29237 | Ep_exp (sharp)  | 0~999999999 | Dword     | R/W            |
| 7236H-7237H                                  | 29238~29239 | Eq_imp (sharp)  | 0~999999999 | Dword     | R/W            |
| 7238H-7239H                                  | 29240~29241 | Eq_exp (sharp)  | 0~999999999 | Dword     | R/W            |
| 723AH-723BH                                  | 29242~29243 | Es (sharp)      | 0~999999999 | Dword     | R/W            |
| 723CH-723DH                                  | 29244~29245 | Ep_imp (peak)   | 0~999999999 | Dword     | R/W            |
| 723EH-723FH                                  | 29246~29247 | Ep_exp (peak)   | 0~999999999 | Dword     | R/W            |
| 7240H-7241H                                  | 29248~29249 | Eq_imp (peak)   | 0~999999999 | Dword     | R/W            |
| 7242H-7243H                                  | 29250~29251 | Eq_exp (peak)   | 0~999999999 | Dword     | R/W            |
| 7244H-7245H                                  | 29252~29253 | Es (peak)       | 0~999999999 | Dword     | R/W            |
| 7246H-7247H                                  | 29254~29255 | Ep_imp (valley) | 0~999999999 | Dword     | R/W            |
| 7248H-7249H                                  | 29256~29257 | Ep_exp (valley) | 0~999999999 | Dword     | R/W            |
| 724AH-724BH                                  | 29258~29259 | Eq_imp (valley) | 0~999999999 | Dword     | R/W            |

## Acuvim II Series Power Meter

| Address(H)  | Address(D)  | Parameters      | Range       | Data Type | Type of Access |
|-------------|-------------|-----------------|-------------|-----------|----------------|
| 724CH~724DH | 29260~29261 | Eq_exp (valley) | 0~999999999 | Dword     | R/W            |
| 724EH~724FH | 29262~29263 | Es (valley)     | 0~999999999 | Dword     | R/W            |
| 7250H~7251H | 29264~29265 | Ep_imp (normal) | 0~999999999 | Dword     | R/W            |
| 7252H~7253H | 29266~29267 | Ep_exp (normal) | 0~999999999 | Dword     | R/W            |
| 7254H~7255H | 29268~29269 | Eq_imp (normal) | 0~999999999 | Dword     | R/W            |
| 7256H~7257H | 29270~29271 | Eq_exp (normal) | 0~999999999 | Dword     | R/W            |
| 7258H~7259H | 29272~29273 | Es (normal)     | 0~999999999 | Dword     | R/W            |
| 725AH~725BH | 29274~29275 | Ep_imp (sum)    | 0~999999999 | Dword     | R/W            |
| 725CH~725DH | 29276~29277 | Ep_exp (sum)    | 0~999999999 | Dword     | R/W            |
| 725EH~725FH | 29278~29279 | Eq_imp (sum)    | 0~999999999 | Dword     | R/W            |
| 7260H~7261H | 20280~29281 | Eq_exp (sum)    | 0~999999999 | Dword     | R/W            |
| 7262H~7263H | 29282~29283 | Es (sum)        | 0~999999999 | Dword     | R/W            |

Table 6-62

| Address(H)                      | Address(D)  | Parameters      | Range       | Data Type | Type of Access |
|---------------------------------|-------------|-----------------|-------------|-----------|----------------|
| <b>Current month TOU energy</b> |             |                 |             |           |                |
| 7300H~7301H                     | 29440~29441 | Ep_imp (sharp)  | 0~999999999 | Dword     | R/W            |
| 7302H~7303H                     | 29442~29443 | Ep_exp (sharp)  | 0~999999999 | Dword     | R/W            |
| 7304H~7305H                     | 29444~29445 | Eq_imp (sharp)  | 0~999999999 | Dword     | R/W            |
| 7306H~7307H                     | 29446~29447 | Eq_exp (sharp)  | 0~999999999 | Dword     | R/W            |
| 7308H~7309H                     | 29448~29449 | Es (sharp)      | 0~999999999 | Dword     | R/W            |
| 730AH~730BH                     | 29450~29451 | Ep_imp (peak)   | 0~999999999 | Dword     | R/W            |
| 730CH~730DH                     | 29452~29453 | Ep_exp (peak)   | 0~999999999 | Dword     | R/W            |
| 730EH~730FH                     | 29454~29455 | Eq_imp (peak)   | 0~999999999 | Dword     | R/W            |
| 7310H~7311H                     | 29456~29457 | Eq_exp (peak)   | 0~999999999 | Dword     | R/W            |
| 7312H~7313H                     | 29458~29459 | Es (peak)       | 0~999999999 | Dword     | R/W            |
| 7314H~7315H                     | 29460~29461 | Ep_imp (valley) | 0~999999999 | Dword     | R/W            |
| 7316H~7317H                     | 29462~29463 | Ep_exp (valley) | 0~999999999 | Dword     | R/W            |
| 7318H~7319H                     | 29464~29465 | Eq_imp (valley) | 0~999999999 | Dword     | R/W            |
| 731AH~731BH                     | 29466~29467 | Eq_exp (valley) | 0~999999999 | Dword     | R/W            |

| Address(H)                    | Address(D)  | Parameters      | Range       | Data Type | Type of Access |
|-------------------------------|-------------|-----------------|-------------|-----------|----------------|
| 731CH-731DH                   | 29468~29469 | Es (valley)     | 0~999999999 | Dword     | R/W            |
| 731EH-731FH                   | 29470~29471 | Ep_imp (normal) | 0~999999999 | Dword     | R/W            |
| 7320H-7321H                   | 29472~29473 | Ep_exp (normal) | 0~999999999 | Dword     | R/W            |
| 7322H-7323H                   | 29474~29475 | Eq_imp (normal) | 0~999999999 | Dword     | R/W            |
| 7324H-7325H                   | 29476~29477 | Eq_exp (normal) | 0~999999999 | Dword     | R/W            |
| 7326H-7327H                   | 29478~29479 | Es (normal)     | 0~999999999 | Dword     | R/W            |
| 7328H-7329H                   | 29480~29481 | Ep_imp (sum)    | 0~999999999 | Dword     | R/W            |
| 732AH-732BH                   | 29482~29483 | Ep_exp (sum)    | 0~999999999 | Dword     | R/W            |
| 732CH-732DH                   | 29484~29485 | Eq_imp (sum)    | 0~999999999 | Dword     | R/W            |
| 732EH-732FH                   | 29486~29487 | Eq_exp (sum)    | 0~999999999 | Dword     | R/W            |
| 7330H-7331H                   | 29488~29489 | Es (sum)        | 0~999999999 | Dword     | R/W            |
| <b>Prior month TOU energy</b> |             |                 |             |           |                |
| 7332H-7333H                   | 29490~29491 | Ep_imp (sharp)  | 0~999999999 | Dword     | R/W            |
| 7334H-7335H                   | 29492~29493 | Ep_exp (sharp)  | 0~999999999 | Dword     | R/W            |
| 7336H-7337H                   | 29494~29495 | Eq_imp (sharp)  | 0~999999999 | Dword     | R/W            |
| 7338H-7339H                   | 29496~29497 | Eq_exp (sharp)  | 0~999999999 | Dword     | R/W            |
| 733AH-733BH                   | 29498~29499 | Es (sharp)      | 0~999999999 | Dword     | R/W            |
| 733CH-733DH                   | 29500~29501 | Ep_imp (sharp)  | 0~999999999 | Dword     | R/W            |
| 733EH-733FH                   | 29502~29503 | Ep_exp (sharp)  | 0~999999999 | Dword     | R/W            |
| 7340H-7341H                   | 29504~29505 | Eq_imp (sharp)  | 0~999999999 | Dword     | R/W            |
| 7342H-7343H                   | 29506~29507 | Eq_exp (sharp)  | 0~999999999 | Dword     | R/W            |
| 7344H-7345H                   | 29508~29509 | Es (sharp)      | 0~999999999 | Dword     | R/W            |
| 7346H-7347H                   | 29510~29511 | Ep_imp (sharp)  | 0~999999999 | Dword     | R/W            |
| 7348H-7349H                   | 29512~29513 | Ep_exp (sharp)  | 0~999999999 | Dword     | R/W            |
| 734AH-734BH                   | 29514~29515 | Eq_imp (sharp)  | 0~999999999 | Dword     | R/W            |
| 734CH-734DH                   | 29516~29517 | Eq_exp (sharp)  | 0~999999999 | Dword     | R/W            |
| 734EH-734FH                   | 29518~29519 | Es (sharp)      | 0~999999999 | Dword     | R/W            |
| 7350H-7351H                   | 29220~29221 | Ep_imp (sharp)  | 0~999999999 | Dword     | R/W            |
| 7352H-7353H                   | 29222~29223 | Ep_exp (sharp)  | 0~999999999 | Dword     | R/W            |
| 7354H-7355H                   | 29224~29225 | Eq_imp (sharp)  | 0~999999999 | Dword     | R/W            |
| 7356H-7357H                   | 29226~29227 | Eq_exp (sharp)  | 0~999999999 | Dword     | R/W            |

## Acuvim II Series Power Meter

| Address(H)  | Address(D)   | Parameters     | Range       | Data Type | Type of Access |
|-------------|--------------|----------------|-------------|-----------|----------------|
| 7358H-7359H | 29228~29229I | Es (sharp)     | 0~999999999 | Dword     | R/W            |
| 735AH-735BH | 29230~29231  | Ep_imp (sharp) | 0~999999999 | Dword     | R/W            |
| 735CH-735DH | 29232~29233  | Ep_exp (sharp) | 0~999999999 | Dword     | R/W            |
| 735EH-735FH | 29234~29235  | Eq_imp (sharp) | 0~999999999 | Dword     | R/W            |
| 7360H-7361H | 29236~29237  | Eq_exp (sharp) | 0~999999999 | Dword     | R/W            |
| 7362H-7363H | 29538~29539  | Es (sharp)     | 0~999999999 | Dword     | R/W            |

The address area includes the max of Ep\_imp, Ep\_exp, Eq\_imp, Eq\_exp, Es, Current demand, and timestamp, when tariff setting parameters are sharp, peak, valley, and normal. Function: 03H Read.

Table 6-63

| Address(H)  | Address(D)  | Parameters  | Range            | Data Type | Type of Access |
|-------------|-------------|---|------------------|-----------|----------------|
| 7500H-7503H | 29952~29955 | Max of Ep_imp (sharp) demand and timestamp (format: power; year/month; Day/Hour; Min/Sec) | -<br>32768~32767 | Int       | R              |
| 7504H-7507H | 29956~29959 | Max of Ep_exp (sharp) demand and timestamp  | -<br>32768~32767 | Int       | R              |
| 7508H-750BH | 29960~29963 | Max of Eq_imp (sharp) demand and timestamp  | -<br>32768~32767 | Int       | R              |
| 750CH-750FH | 29964~29967 | Max of Eq_exp (sharp) demand and timestamp  | -<br>32768~32767 | Int       | R              |
| 7510H-7513H | 29968~29971 | Max of Es (sharp) demand and timestamp  | -<br>32768~32767 | Int       | R              |
| 7514H-7517H | 29972~29975 | Max of Ia (sharp) demand and timestamp  | -<br>32768~32767 | Int       | R              |
| 7518H-751BH | 29976~29979 | Max of Ib (sharp) demand and timestamp  | -<br>32768~32767 | Int       | R              |
| 751CH-751FH | 29980~29983 | Max of Ic (sharp) demand and timestamp  | -<br>32768~32767 | Int       | R              |
| 7520H-7523H | 29984~29987 | Max of Ep_imp (peak) demand and timestamp   | -<br>32768~32767 | Int       | R              |
| 7524H-7527H | 29988~29991 | Max of Ep_exp (peak) demand and timestamp   | -<br>32768~32767 | Int       | R              |
| 7528H-752BH | 29992~29995 | Max of Eq_imp (peak) demand and timestamp   | -<br>32768~32767 | Int       | R              |
| 752CH-752FH | 29996~29999 | Max of Eq_exp (peak) demand and timestamp   | -<br>32768~32767 | Int       | R              |

Chapter 6: Communication Part II

| Address(H)  | Address(D)  | Parameters                                  | Range            | Data Type | Type of Access |
|-------------|-------------|---|------------------|-----------|----------------|
| 7530H-7533H | 30000-30003 | Max of Es (peak) demand and timestamp       | -<br>32768-32767 | Int       | R              |
| 7534H-7537H | 30004-30007 | Max of Ia (peak) demand and timestamp       | -<br>32768-32767 | Int       | R              |
| 7538H-753BH | 30008-30011 | Max of Ib (peak) demand and timestamp       | -<br>32768-32767 | Int       | R              |
| 753CH-753FH | 30012-30015 | Max of Ic (peak) demand and timestamp       | -<br>32768-32767 | Int       | R              |
| 7540H-7543H | 30016-30019 | Max of Ep_imp (valley) demand and timestamp | -<br>32768-32767 | Int       | R              |
| 7544H-7547H | 30020-30023 | Max of Ep_exp (valley) demand and timestamp | -<br>32768-32767 | Int       | R              |
| 7548H-754BH | 30024-30027 | Max of Eq_imp (valley) demand and timestamp | -<br>32768-32767 | Int       | R              |
| 754CH-754FH | 30028-30031 | Max of Eq_exp (valley) demand and timestamp | -<br>32768-32767 | Int       | R              |
| 7550H-7553H | 30032-30035 | Max of Es (valley) demand and timestamp     | -<br>32768-32767 | Int       | R              |
| 7554H-7557H | 30036-30039 | Max of Ia (valley) demand and timestamp     | -<br>32768-32767 | Int       | R              |
| 7558H-755BH | 30040-30043 | Max of Ib (valley) demand and timestamp     | -<br>32768-32767 | Int       | R              |
| 755CH-755FH | 30044-30047 | Max of Ic (valley) demand and timestamp     | -<br>32768-32767 | Int       | R              |
| 7560H-7563H | 30048-30051 | Max of Ep_imp (normal) demand and timestamp | -<br>32768-32767 | Int       | R              |
| 7564H-7567H | 30052-30055 | Max of Ep_exp (normal) demand and timestamp | -<br>32768-32767 | Int       | R              |
| 7568H-756BH | 30056-30059 | Max of Eq_imp (normal) demand and timestamp | -<br>32768-32767 | Int       | R              |
| 756CH-756FH | 30060-30063 | Max of Eq_exp (normal) demand and timestamp | -<br>32768-32767 | Int       | R              |
| 7570H-7573H | 30064-30067 | Max of Es (normal) demand and timestamp     | -<br>32768-32767 | Int       | R              |
| 7574H-7577H | 30068-30071 | Max of Ia (normal) demand and timestamp     | -<br>32768-32767 | Int       | R              |
| 7578H-757BH | 30072-30075 | Max of Ib (normal) demand and timestamp     | -<br>32768-32767 | Int       | R              |
| 757CH-757FH | 30076-30079 | Max of Ic (normal) demand and timestamp     | -<br>32768-32767 | Int       | R              |
| 7580H-7583H | 30080-30083 | Max of Ep_imp (all) demand and timestamp    | -<br>32768-32767 | Int       | R              |

## Acuvim II Series Power Meter

| Address(H)  | Address(D)  | Parameters                               | Range            | Data Type | Type of Access |
|-------------|-------------|--|------------------|-----------|----------------|
| 7584H-7587H | 30084-30087 | Max of Ep_exp (all) demand and timestamp | -<br>32768-32767 | Int       | R              |
| 7588H-758BH | 30088-30091 | Max of Eq_imp (all) demand and timestamp | -<br>32768-32767 | Int       | R              |
| 758CH-758FH | 30092-30095 | Max of Eq_exp (all) demand and timestamp | -<br>32768-32767 | Int       | R              |
| 7590H-7593H | 30096-30099 | Max of Es (all) demand and timestamp     | -<br>32768-32767 | Int       | R              |
| 7594H-7597H | 30100-30103 | Max of Ia (all) demand and timestamp     | -<br>32768-32767 | Int       | R              |
| 7598H-759BH | 30104-30107 | Max of Ib (all) demand and timestamp     | -<br>32768-32767 | Int       | R              |
| 759CH-759FH | 30108-30111 | Max of Ic (all) demand and timestamp     | -<br>32768-32767 | Int       | R              |

The address area includes Daylight savings time (DST) setting. Function: 03H Read, 10H Preset.

Table 6-64

| Address(H)      | Address(D) | Parameters                         | Range                    | Data Type | Type of Access |
|-----------------|------------|------------------------------------|--------------------------|-----------|----------------|
| 7700H           | 30464      | DST enable                         | 0: Disable, 1: Enable    | Word      | R/W            |
| 7701H           | 30465      | DST format                         | 0: Format 1, 1: Format 2 | Word      | R/W            |
| <b>Format 1</b> |            |                                    |                          |           |                |
| 7702H           | 30466      | DST start Mon                      | 1~12                     | Word      | R/W            |
| 7703H           | 30467      | DST start Day                      | 1~31                     | Word      | R/W            |
| 7704H           | 30468      | DST start Hour                     | 0~23                     | Word      | R/W            |
| 7705H           | 30469      | DST start Min                      | 0~59                     | Word      | R/W            |
| 7706H           | 30470      | DST start adjust time (Unit: Min)  | 1~120 (Default: 60)      | Word      | R/W            |
| 7707H           | 30471      | DST ending Mon                     | 1~12                     | Word      | R/W            |
| 7708H           | 30472      | DST ending Day                     | 1~31                     | Word      | R/W            |
| 7709H           | 30473      | DST ending Hour                    | 0~23                     | Word      | R/W            |
| 770AH           | 30474      | DST ending Min                     | 0~59                     | Word      | R/W            |
| 770BH           | 30475      | DST ending adjust time (Unit: Min) | 1~120 (Default: 60)      | Word      | R/W            |
| <b>Format 2</b> |            |                                    |                          |           |                |
| 770CH           | 30476      | DST start Mon                      | 1~12                     | Word      | R/W            |

| Address(H) | Address(D) | Parameters                         | Range                                | Data Type | Type of Access |
|------------|------------|------------------------------------|--------------------------------------|-----------|----------------|
| 770DH      | 30477      | DST start Week                     | 0: Sunday<br>1~6, Monday to Saturday | Word      | R/W            |
| 770EH      | 30478      | DST start first few Weeks          | 1~5                                  | Word      | R/W            |
| 770FH      | 30479      | DST start Hour                     | 0~23                                 | Word      | R/W            |
| 7710H      | 30480      | DST start Min                      | 0~59                                 | Word      | R/W            |
| 7711H      | 30481      | DST start adjust time (Unit: Min)  | 1~120 (Default: 60)                  | Word      | R/W            |
| 7712H      | 30482      | DST ending Mon                     | 1~12                                 | Word      | R/W            |
| 7713H      | 30483      | DST ending Week                    | 0: Sunday<br>1~6, Monday to Saturday | Word      | R/W            |
| 7714H      | 30484      | DST ending first few Weeks         | 1~5                                  | Word      | R/W            |
| 7715H      | 30485      | DST ending Hour                    | 0~23                                 | Word      | R/W            |
| 7716H      | 30486      | DST ending Min                     | 0~59                                 | Word      | R/W            |
| 7717H      | 30487      | DST ending adjust time (Unit: Min) | 1~120 (Default: 60)                  | Word      | R/W            |

Data address of TOU parameter setting includes basis parameter of TOU, time zone setting parameter of TOU, timetable setting parameter of TOU, and holiday setting parameter of TOU. Function: 03 code, 10 reset.

Table 6-65

| Address(H)                    | Address(D) | Parameters   | Range | Data Type | Type of Access |
|-------------------------------|------------|--|-------|-----------|----------------|
| <b>Basis parameter of TOU</b> |            |  |       |           |                |
| 7800H                         | 30720      | Season number  | 0~12  | Word      | R/W            |
| 7801H                         | 30721      | Schedule number  | 0~14  | Word      | R/W            |
| 7802H                         | 30722      | Segment number   | 0~14  | Word      | R/W            |
| 7803H                         | 30723      | Tariff number  | 0~3   | Word      | R/W            |
| 7804H                         | 30724      | Weekend setting (bit0-Sunday; bit 1~bit6: Monday~Saturday<br>bit=1 means using energy, bit=0 means not using energy) | 0~127 | Word      | R/W            |
| 7805H                         | 30725      | Weekend schedule   | 0~14  | Word      | R/W            |
| 7806H                         | 30726      | Holiday number   | 0~30  | Word      | R/W            |

## Acuvim II Series Power Meter

| Address(H)            | Address(D)  | Parameters   | Range   | Data Type | Type of Access |
|-----------------------|-------------|--|---|-----------|----------------|
| 7807H                 | 30727       | TOU factory setting                                | 1: Enable   | Word      | R/W            |
| 7808H                 | 30728       | Choice of calculation auto reset (0: End of Month) | 1: Enable   | Word      | R/W            |
| 7809H                 | 30729       | TOU auto reset fixed date: day (default is 1)      |   | Word      | R/W            |
| 780AH                 | 30730       | TOU auto reset fixed date: hour (default is 0)     | 0~31  | Word      | R/W            |
| 780BH                 | 30731       | TOU auto reset fixed date: minute (default is 0)   | 0~23  | Word      | R/W            |
| 780CH                 | 30732       | TOU auto reset fixed date: second (default is 0)   | 0~59  | Word      | R/W            |
| 780DH                 | 30733       | TOU auto reset fixed date: second (default is 0)   | 0~59  | Word      | R/W            |
| 780EH                 | 30734       | Error code (default is 0)                          | 0: the setting of parameter is correct;<br>1: tariff setting error;<br>2: schedule setting error;<br>4: segment setting error;<br>8: season setting error;<br>16: parameter of season setting error;<br>32: holiday setting error;<br>64: parameter of holiday setting error;<br>256: tariff of schedule setting error;<br>512: time of schedule setting error;<br>1024: period of schedule setting error;<br>2048: period of weekend setting error;<br>4096: weekend setting error | Word      | R/W            |
| <b>Season setting</b> |             |  |   |           |                |
| 7820H~7822H           | 30752~30754 | Data and season table of the 1st season            |   | Word      | R/W            |

| Address(H)              | Address(D)  | Parameters  | Range | Data Type | Type of Access |
|-------------------------|-------------|---|-------|-----------|----------------|
| 7823H~7825H             | 30755~30757 | Data and season table of the 2nd season           |       | Word      | R/W            |
| 7826H~7828H             | 30758~30760 | Data and season table of the 3rd season           |       | Word      | R/W            |
| 7829H~782BH             | 30761~30763 | Data and season table of the 4th season           |       | Word      | R/W            |
| 782CH~782EH             | 30764~30766 | Data and season table of the 5th season           |       | Word      | R/W            |
| 782FH~7831H             | 30767~30769 | Data and season table of the 6th season           |       | Word      | R/W            |
| 7832H~7834H             | 30770~30772 | Data and season table of the 7th season           |       | Word      | R/W            |
| 7835H~7837H             | 30773~30775 | Data and season table of the 8th season           |       | Word      | R/W            |
| 7838H~783AH             | 30776~30778 | Data and season table of the 9th season           |       | Word      | R/W            |
| 783BH~783DH             | 30779~30781 | Data and season table of the 10th season          |       | Word      | R/W            |
| 783EH~7840H             | 30782~30784 | Data and season table of the 11th season          |       | Word      | R/W            |
| 7841H~7843H             | 30785~30787 | Data and season table of the 12th season          |       | Word      | R/W            |
| <b>Schedule setting</b> |             |   |       |           |                |
| 7844H~7846H             | 30788~30790 | 1st segment and tariff number of the 1st schedule |       | Word      | R/W            |
| 7847H~7849H             | 30791~30793 | 2nd segment and tariff number of the 1st schedule |       | Word      | R/W            |
| 784AH~784CH             | 30794~30796 | 3rd segment and tariff number of the 1st schedule |       | Word      | R/W            |
| 784DH~784FH             | 30797~30799 | 4th segment and tariff number of the 1st schedule |       | Word      | R/W            |
| 7850H~7852H             | 30800~30802 | 5th segment and tariff number of the 1st schedule |       | Word      | R/W            |
| 7853H~7855H             | 30803~30805 | 6th segment and tariff number of the 1st schedule |       | Word      | R/W            |
| 7856H~7858H             | 30806~30808 | 7th segment and tariff number of the 1st schedule |       | Word      | R/W            |
| 7859H~785BH             | 30809~30811 | 8th segment and tariff number of the 1st schedule |       | Word      | R/W            |
| 785CH~785EH             | 30812~30814 | 9th segment and tariff number of the 1st schedule |       | Word      | R/W            |

## Acuvim II Series Power Meter

| Address(H)  | Address(D)  | Parameters  | Range                        | Data Type | Type of Access |
|-------------|-------------|---|------------------------------|-----------|----------------|
| 785FH~7861H | 30815~30817 | 10th segment and tariff number of the 1st schedule              |                              | Word      | R/W            |
| 7862H~7864H | 30818~30820 | 11th segment and tariff number of the 1st schedule              |                              | Word      | R/W            |
| 7865H~7867H | 30821~30823 | 12th segment and tariff number of the 1st schedule              |                              | Word      | R/W            |
| 7868H~786AH | 30824~30826 | 13th segment and tariff number of the 1st schedule              |                              | Word      | R/W            |
| 786BH~786DH | 30827~30829 | 14th segment and tariff number of the 1st schedule              |                              | Word      | R/W            |
| 786EH~7897H | 30830~30871 | From 1st to 14th segment and tariff number of the 2nd schedule  | The same as the 1st schedule | Word      | R/W            |
| 7898H~78C1H | 30872~30913 | From 1st to 14th segment and tariff number of the 3rd schedule  | The same as the 1st schedule | Word      | R/W            |
| 78C2H~78EBH | 30914~30955 | From 1st to 14th segment and tariff number of the 4th schedule  | The same as the 1st schedule | Word      | R/W            |
| 78ECH~7915H | 30956~30997 | From 1st to 14th segment and tariff number of the 5th schedule  | The same as the 1st schedule | Word      | R/W            |
| 7916H~793FH | 30998~31039 | From 1st to 14th segment and tariff number of the 6th schedule  | The same as the 1st schedule | Word      | R/W            |
| 7940H~7969H | 31040~31081 | From 1st to 14th segment and tariff number of the 7th schedule  | The same as the 1st schedule | Word      | R/W            |
| 796AH~7993H | 31082~31123 | From 1st to 14th segment and tariff number of the 8th schedule  | The same as the 1st schedule | Word      | R/W            |
| 7994H~79BDH | 31124~31165 | From 1st to 14th segment and tariff number of the 9th schedule  | The same as the 1st schedule | Word      | R/W            |
| 79BEH~79E7H | 31166~31207 | From 1st to 14th segment and tariff number of the 10th schedule | The same as the 1st schedule | Word      | R/W            |
| 79E8H~7A11H | 31208~31249 | From 1st to 14th segment and tariff number of the 11th schedule | The same as the 1st schedule | Word      | R/W            |
| 7A12H~7A3BH | 31250~31291 | From 1st to 14th segment and tariff number of the 12th schedule | The same as the 1st schedule | Word      | R/W            |

| Address(H)             | Address(D)  | Parameters  | Range                        | Data Type | Type of Access |
|------------------------|-------------|---|------------------------------|-----------|----------------|
| 7A3CH~7A65H            | 31292~31333 | From 1st to 14th segment and tariff number of the 13th schedule | The same as the 1st schedule | Word      | R/W            |
| 7A66H~7A8FH            | 31334~31375 | From 1st to 14th segment and tariff number of the 14th schedule | The same as the 1st schedule | Word      | R/W            |
| <b>Holiday setting</b> |             |   |                              |           |                |
| 7A90H~7A92H            | 31376~31378 | Data and the schedule of the 1st holiday                        |                              | Word      | R/W            |
| 7A93H~7A95H            | 31379~31381 | Data and the schedule of the 2nd holiday                        |                              | Word      | R/W            |
| 7A96H~7A98H            | 31382~31384 | Data and the schedule of the 3rd holiday                        |                              | Word      | R/W            |
| 7A99H~7A9BH            | 31385~31387 | Data and the schedule of the 4th holiday                        |                              | Word      | R/W            |
| 7A9CH~7A9EH            | 31388~31390 | Data and the schedule of the 5th holiday                        |                              | Word      | R/W            |
| 7A9FH~7AA1H            | 31391~31393 | Data and the schedule of the 6th holiday                        |                              | Word      | R/W            |
| 7AA2H~7AA4H            | 31394~31396 | Data and the schedule of the 7th holiday                        |                              | Word      | R/W            |
| 7AA5H~7AA7H            | 31397~31399 | Data and the schedule of the 8th holiday                        |                              | Word      | R/W            |
| 7AA8H~7AAAH            | 31400~31402 | Data and the schedule of the 9th holiday                        |                              | Word      | R/W            |
| 7AABH~7AADH            | 31403~31405 | Data and the schedule of the 10th holiday                       |                              | Word      | R/W            |
| 7AAEH~7AB0H            | 31406~31408 | Data and the schedule of the 11th holiday                       |                              | Word      | R/W            |
| 7AB1H~7AB3H            | 31409~31411 | Data and the schedule of the 12th holiday                       |                              | Word      | R/W            |
| 7AB4H~7AB6H            | 31412~31414 | Data and the schedule of the 13th holiday                       |                              | Word      | R/W            |
| 7AB7H~7AB9H            | 31415~31417 | Data and the schedule of the 14th holiday                       |                              | Word      | R/W            |
| 7ABAH~7ABCH            | 31418~31420 | Data and the schedule of the 15th holiday                       |                              | Word      | R/W            |
| 7ABDH~7ABFH            | 31421~31423 | Data and the schedule of the 16th holiday                       |                              | Word      | R/W            |

## Acuvim II Series Power Meter

| Address(H)  | Address(D)  | Parameters                                | Range | Data Type | Type of Access |
|-------------|-------------|---|-------|-----------|----------------|
| 7AC0H~7AC2H | 31424~31426 | Data and the schedule of the 17th holiday |       | Word      | R/W            |
| 7AC3H~7AC5H | 31427~31429 | Data and the schedule of the 18th holiday |       | Word      | R/W            |
| 7AC6H~7AC8H | 31430~31432 | Data and the schedule of the 19th holiday |       | Word      | R/W            |
| 7AC9H~7ACBH | 31433~31435 | Data and the schedule of the 20th holiday |       | Word      | R/W            |
| 7ACCH~7ACEH | 31436~31438 | Data and the schedule of the 21st holiday |       | Word      | R/W            |
| 7ACFH~7AD1H | 31439~31441 | Data and the schedule of the 22nd holiday |       | Word      | R/W            |
| 7AD2H~7AD4H | 31442~31444 | Data and the schedule of the 23rd holiday |       | Word      | R/W            |
| 7AD5H~7AD7H | 31445~31447 | Data and the schedule of the 24th holiday |       | Word      | R/W            |
| 7AD8H~7ADAH | 31448~31450 | Data and the schedule of the 25th holiday |       | Word      | R/W            |
| 7ADBH~7ADDH | 31451~31453 | Data and the schedule of the 26th holiday |       | Word      | R/W            |
| 7ADEH~7AE0H | 31454~31456 | Data and the schedule of the 27th holiday |       | Word      | R/W            |
| 7AE1H~7AE3H | 31457~31459 | Data and the schedule of the 28th holiday |       | Word      | R/W            |
| 7AE4H~7AE6H | 31460~31462 | Data and the schedule of the 29th holiday |       | Word      | R/W            |
| 7AE7H~7AE9H | 31463~31465 | Data and the schedule of the 30th holiday |       | Word      | R/W            |
| 7AEAH       | 31466       | Holiday setting enable                    |       | Word      | R/W            |
| 7AEBH       | 31467       | Start year holiday setting                |       | Word      | R/W            |
| 7AECH       | 31468       | End year holiday setting                  |       | Word      | R/W            |

The address area includes ten years holiday setting, Function: 03H Read 10H Preset.

Table 6-66

| The 1st Year Holiday Address Function: 03H Read 10H Preset |             |   |           |                |
|--|-------------|---|-----------|----------------|
| Address(H)   | Address(D)  | Parameters  | Data Type | Type of Access |
| 7B00H~7B02H  | 31488~31490 | The 1st holiday and schedule (format: month/day/schedule) | Word      | R/W            |
| 7B03H~7B05H  | 31491~31493 | The 2nd holiday and schedule                              | Word      | R/W            |
| 7B06H~7B08H  | 31494~31496 | The 3rd holiday and schedule                              | Word      | R/W            |
| 7B09H~7B0BH  | 31497~31499 | The 4th holiday and schedule                              | Word      | R/W            |
| 7B0CH~7B0EH  | 31500~31502 | The 5th holiday and schedule                              | Word      | R/W            |
| 7B0FH~7B11H  | 31503~31505 | The 6th holiday and schedule                              | Word      | R/W            |
| 7B12H~7B14H  | 31506~31508 | The 7th holiday and schedule                              | Word      | R/W            |
| 7B15H~7B17H  | 31509~31511 | The 8th holiday and schedule                              | Word      | R/W            |
| 7B18H~7B1AH  | 31512~31514 | The 9th holiday and schedule                              | Word      | R/W            |
| 7B1BH~7B1DH  | 31515~31517 | The 10th holiday and schedule                             | Word      | R/W            |
| 7B1EH~7B20H  | 31518~31520 | The 11th holiday and schedule                             | Word      | R/W            |
| 7B21H~7B23H  | 31521~31523 | The 12th holiday and schedule                             | Word      | R/W            |
| 7B24H~7B26H  | 31524~31526 | The 13th holiday and schedule                             | Word      | R/W            |
| 7B27H~7B29H  | 31527~31529 | The 14th holiday and schedule                             | Word      | R/W            |
| 7B2AH~7B2CH  | 31530~31532 | The 15th holiday and schedule                             | Word      | R/W            |
| 7B2DH~7B2FH  | 31533~31535 | The 16th holiday and schedule                             | Word      | R/W            |
| 7B30H~7B32H  | 31536~31538 | The 17th holiday and schedule                             | Word      | R/W            |
| 7B33H~7B35H  | 31539~31541 | The 18th holiday and schedule                             | Word      | R/W            |
| 7B36H~7B38H  | 31542~31544 | The 19th holiday and schedule                             | Word      | R/W            |
| 7B39H~7B3BH  | 31545~31547 | The 20th holiday and schedule                             | Word      | R/W            |
| 7B3CH~7B3EH  | 31548~31550 | The 21st holiday and schedule                             | Word      | R/W            |
| 7B3FH~7B41H  | 31551~31553 | The 22nd holiday and schedule                             | Word      | R/W            |
| 7B42H~7B44H  | 31554~31556 | The 23rd holiday and schedule                             | Word      | R/W            |
| 7B45H~7B47H  | 31557~31559 | The 24th holiday and schedule                             | Word      | R/W            |
| 7B48H~7B4AH  | 31560~31562 | The 25th holiday and schedule                             | Word      | R/W            |
| 7B4BH~7B4DH  | 31563~31565 | The 26th holiday and schedule                             | Word      | R/W            |
| 7B4EH~7B50H  | 31566~31568 | The 27th holiday and schedule                             | Word      | R/W            |
| 7B51H~7B53H  | 31569~31571 | The 28th holiday and schedule                             | Word      | R/W            |
| 7B54H~7B56H  | 31572~31574 | The 29th holiday and schedule                             | Word      | R/W            |
| 7B57H~7B59H  | 31575~31577 | The 30th holiday and schedule                             | Word      | R/W            |

## Acuvim II Series Power Meter

| The 1st Year Holiday Address Function: 03H Read 10H Preset |            |                                |           |                |
|--|------------|--------------------------------|-----------|----------------|
| Address(H)   | Address(D) | Parameters                     | Data Type | Type of Access |
| 7B5AH  | 31578      | The 1st setting year           | Word      | R/W            |
| 7b5BH  | 31579      | Holiday number of the 1st year | Word      | R/W            |

Table 6-67

| The 2nd Year Holiday Address Function: 03H Read 10H Preset |             |  |           |                |
|--|-------------|--|-----------|----------------|
| Address(H)   | Address(D)  | Parameters   | Data Type | Type of Access |
| 7B5CH~7B5EH  | 31580~31582 | The 1st holiday and schedule<br>(format: month/day/schedule) | Word      | R/W            |
| 7B5FH~7B61H  | 31583~31585 | The 2nd holiday and schedule                                 | Word      | R/W            |
| 7B62H~7B64H  | 31586~31588 | The 3rd holiday and schedule                                 | Word      | R/W            |
| 7B65H~7B67H  | 31589~31591 | The 4th holiday and schedule                                 | Word      | R/W            |
| 7B68H~7B6AH  | 31592~31594 | The 5th holiday and schedule                                 | Word      | R/W            |
| 7B6BH~7B6DH  | 31595~31597 | The 6th holiday and schedule                                 | Word      | R/W            |
| 7B6EH~7B70H  | 31598~31600 | The 7th holiday and schedule                                 | Word      | R/W            |
| 7B71H~7B73H  | 31601~31603 | The 8th holiday and schedule                                 | Word      | R/W            |
| 7B74H~7B76H  | 31604~31606 | The 9th holiday and schedule                                 | Word      | R/W            |
| 7B77H~7B79H  | 31607~31609 | The 10th holiday and schedule                                | Word      | R/W            |
| 7B7AH~7B7CH  | 31610~31612 | The 11th holiday and schedule                                | Word      | R/W            |
| 7B7DH~7B7FH  | 31613~31615 | The 12th holiday and schedule                                | Word      | R/W            |
| 7B80H~7B82H  | 31616~31618 | The 13th holiday and schedule                                | Word      | R/W            |
| 7B83H~7B85H  | 31619~31621 | The 14th holiday and schedule                                | Word      | R/W            |
| 7B86H~7B88H  | 31622~31624 | The 15th holiday and schedule                                | Word      | R/W            |
| 7B89H~7B8BH  | 31625~31627 | The 16th holiday and schedule                                | Word      | R/W            |
| 7B8CH~7B8EH  | 31628~31630 | The 17th holiday and schedule                                | Word      | R/W            |
| 7B8FH~7B91H  | 31631~31633 | The 18th holiday and schedule                                | Word      | R/W            |
| 7B92H~7B94H  | 31634~31636 | The 19th holiday and schedule                                | Word      | R/W            |
| 7B95H~7B97H  | 31637~31639 | The 20th holiday and schedule                                | Word      | R/W            |
| 7B98H~7B9AH  | 31640~31642 | The 21st holiday and schedule                                | Word      | R/W            |
| 7B9BH~7B9DH  | 31643~31645 | The 22nd holiday and schedule                                | Word      | R/W            |
| 7B9EH~7BA0H  | 31646~31648 | The 23rd holiday and schedule                                | Word      | R/W            |

| The 2nd Year Holiday Address Function: 03H Read 10H Preset |             |                                |           |                |
|--|-------------|--------------------------------|-----------|----------------|
| Address(H)   | Address(D)  | Parameters                     | Data Type | Type of Access |
| 7BA1H~7BA3H  | 31649~31651 | The 24th holiday and schedule  | Word      | R/W            |
| 7BA4H~7BA6H  | 31652~31654 | The 25th holiday and schedule  | Word      | R/W            |
| 7BA7H~7BA9H  | 31655~31657 | The 26th holiday and schedule  | Word      | R/W            |
| 7BAAH~7BACH  | 31658~31660 | The 27th holiday and schedule  | Word      | R/W            |
| 7BADH~7BAFH  | 31661~31663 | The 28th holiday and schedule  | Word      | R/W            |
| 7BB0H~7BB2H  | 31664~31666 | The 29th holiday and schedule  | Word      | R/W            |
| 7BB3H~7BB5H  | 31667~31669 | The 30th holiday and schedule  | Word      | R/W            |
| 7BB6H  | 31670       | The 2nd setting year           | Word      | R/W            |
| 7BB7H  | 31671       | Holiday number of the 2nd year | Word      | R/W            |

Table 6-68

| The 3rd Year Holiday Address Function: 03H Read 10H Preset |             |  |           |                |
|--|-------------|--|-----------|----------------|
| Address(H)   | Address(D)  | Parameters   | Data Type | Type of Access |
| 7BB8H~7BBAH  | 31672~31674 | The 1st holiday and schedule<br>(format: month/day/schedule) | Word      | R/W            |
| 7BBBH~7BBDH  | 31675~31677 | The 2nd holiday and schedule                                 | Word      | R/W            |
| 7BBEH~7BC0H  | 31678~31680 | The 3rd holiday and schedule                                 | Word      | R/W            |
| 7BC1H~7BC3H  | 31681~31683 | The 4th holiday and schedule                                 | Word      | R/W            |
| 7BC4H~7BC6H  | 31684~31686 | The 5th holiday and schedule                                 | Word      | R/W            |
| 7BC7H~7BC9H  | 31687~31689 | The 6th holiday and schedule                                 | Word      | R/W            |
| 7BCAH~7BCCH  | 31690~31692 | The 7th holiday and schedule                                 | Word      | R/W            |
| 7BCDH~7BCFH  | 31693~31695 | The 8th holiday and schedule                                 | Word      | R/W            |
| 7BD0H~7BD2H  | 31696~31698 | The 9th holiday and schedule                                 | Word      | R/W            |
| 7BD3H~7BD5H  | 31699~31701 | The 10th holiday and schedule                                | Word      | R/W            |
| 7BD6H~7BD8H  | 31702~31704 | The 11th holiday and schedule                                | Word      | R/W            |
| 7BD9H~7BDBH  | 31705~31707 | The 12th holiday and schedule                                | Word      | R/W            |
| 7BDCH~7BDEH  | 31708~31710 | The 13th holiday and schedule                                | Word      | R/W            |
| 7BDFH~7BE1H  | 31711~31713 | The 14th holiday and schedule                                | Word      | R/W            |
| 7BE2H~7BE4H  | 31714~31716 | The 15th holiday and schedule                                | Word      | R/W            |
| 7BE5H~7BE7H  | 31717~31719 | The 16th holiday and schedule                                | Word      | R/W            |

## Acuvim II Series Power Meter

| The 3rd Year Holiday Address Function: 03H Read 10H Preset |             |                                |           |                |
|--|-------------|--------------------------------|-----------|----------------|
| Address(H)   | Address(D)  | Parameters                     | Data Type | Type of Access |
| 7BE8H~7BEAH  | 31720~31722 | The 17th holiday and schedule  | Word      | R/W            |
| 7BEBH~7BEDH  | 31723~31725 | The 18th holiday and schedule  | Word      | R/W            |
| 7BEEH~7BF0H  | 31726~31728 | The 19th holiday and schedule  | Word      | R/W            |
| 7BF1H~7BF3H  | 31729~31731 | The 20th holiday and schedule  | Word      | R/W            |
| 7BF4H~7BF6H  | 31732~31734 | The 21st holiday and schedule  | Word      | R/W            |
| 7BF7H~7BF9H  | 31735~31737 | The 22nd holiday and schedule  | Word      | R/W            |
| 7BFAH~7BFCH  | 31738~31740 | The 23rd holiday and schedule  | Word      | R/W            |
| 7BFDH~7BFFH  | 31741~31743 | The 24th holiday and schedule  | Word      | R/W            |
| 7C00H~7C02H  | 31744~31746 | The 25th holiday and schedule  | Word      | R/W            |
| 7C03H~7C05H  | 31747~31749 | The 26th holiday and schedule  | Word      | R/W            |
| 7C06H~7C08H  | 31750~31752 | The 27th holiday and schedule  | Word      | R/W            |
| 7C09H~7C0BH  | 31753~31755 | The 28th holiday and schedule  | Word      | R/W            |
| 7C0CH~7C0EH  | 31756~31758 | The 29th holiday and schedule  | Word      | R/W            |
| 7C0FH~7C11H  | 31759~31761 | The 30th holiday and schedule  | Word      | R/W            |
| 7C12H  | 31762       | The 3rd setting year           | Word      | R/W            |
| 7C13H  | 31763       | Holiday number of the 3rd year | Word      | R/W            |

Table 6-69

| The 4th Year Holiday Address Function: 03H Read 10H Preset |             |  |           |                |
|--|-------------|--|-----------|----------------|
| Address(H)   | Address(D)  | Parameters   | Data Type | Type of Access |
| 7C14H~7C16H  | 31764~31766 | The 1st holiday and schedule<br>(format: month/day/schedule) | Word      | R/W            |
| 7C17H~7C19H  | 31767~31769 | The 2nd holiday and schedule                                 | Word      | R/W            |
| 7C1AH~7C1CH  | 31770~31772 | The 3rd holiday and schedule                                 | Word      | R/W            |
| 7C1DH~7C1FH  | 31773~31775 | The 4th holiday and schedule                                 | Word      | R/W            |
| 7C20H~7C22H  | 31776~31778 | The 5th holiday and schedule                                 | Word      | R/W            |
| 7C23H~7C25H  | 31779~31871 | The 6th holiday and schedule                                 | Word      | R/W            |
| 7C26H~7C28H  | 31782~31874 | The 7th holiday and schedule                                 | Word      | R/W            |
| 7C29H~7C2BH  | 31785~31787 | The 8th holiday and schedule                                 | Word      | R/W            |
| 7C2CH~7C22H  | 31788~31790 | The 9th holiday and schedule                                 | Word      | R/W            |

| The 4th Year Holiday Address Function: 03H Read 10H Preset |             |                                |           |                |
|--|-------------|--------------------------------|-----------|----------------|
| Address(H)   | Address(D)  | Parameters                     | Data Type | Type of Access |
| 7C2FH~7C31H  | 31791~31793 | The 10th holiday and schedule  | Word      | R/W            |
| 7C32H~7C34H  | 31794~31796 | The 11th holiday and schedule  | Word      | R/W            |
| 7C35H~7C37H  | 31797~31799 | The 12th holiday and schedule  | Word      | R/W            |
| 7C38H~7C3AH  | 31800~31802 | The 13th holiday and schedule  | Word      | R/W            |
| 7C3BH~7C3DH  | 31803~31805 | The 14th holiday and schedule  | Word      | R/W            |
| 7C3EH~7C40H  | 31806~31808 | The 15th holiday and schedule  | Word      | R/W            |
| 7C41H~7C43H  | 31809~31811 | The 16th holiday and schedule  | Word      | R/W            |
| 7C44H~7C46H  | 31812~31814 | The 17th holiday and schedule  | Word      | R/W            |
| 7C47H~7C49H  | 31815~31817 | The 18th holiday and schedule  | Word      | R/W            |
| 7C4AH~7C4CH  | 31818~31820 | The 19th holiday and schedule  | Word      | R/W            |
| 7C4DH~7C4FH  | 31821~31823 | The 20th holiday and schedule  | Word      | R/W            |
| 7C50H~7C52H  | 31824~31826 | The 21st holiday and schedule  | Word      | R/W            |
| 7C53H~7C55H  | 31827~31829 | The 22nd holiday and schedule  | Word      | R/W            |
| 7C56H~7C58H  | 31830~31832 | The 23rd holiday and schedule  | Word      | R/W            |
| 7C59H~7C5BH  | 31833~31835 | The 24th holiday and schedule  | Word      | R/W            |
| 7C5CH~7C5EH  | 31836~31838 | The 25th holiday and schedule  | Word      | R/W            |
| 7C5FH~7C61H  | 31839~31841 | The 26th holiday and schedule  | Word      | R/W            |
| 7C62H~7C64H  | 31842~31844 | The 27th holiday and schedule  | Word      | R/W            |
| 7C65H~7C67H  | 31845~31847 | The 28th holiday and schedule  | Word      | R/W            |
| 7C68H~7C6AH  | 31848~31850 | The 29th holiday and schedule  | Word      | R/W            |
| 7C68H~7C6AH  | 31851~31853 | The 30th holiday and schedule  | Word      | R/W            |
| 7C6EH  | 31854       | The 4th setting year           | Word      | R/W            |
| 7C6FH  | 31855       | Holiday number of the 4th year | Word      | R/W            |

Table 6-70

| The 5th Year Holiday Address Function: 03H Read 10H Preset |             |  |           |                |
|--|-------------|--|-----------|----------------|
| Address(H)   | Address(D)  | Parameters   | Data Type | Type of Access |
| 7C70H~7C72H  | 31856~31858 | The 1st holiday and schedule<br>(format: month/day/schedule) | Word      | R/W            |
| 7C73H~7C75H  | 31859~31861 | The 2nd holiday and schedule                                 | Word      | R/W            |

## Acuvim II Series Power Meter

| The 5th Year Holiday Address Function: 03H Read 10H Preset |             |                                |           |                |
|--|-------------|--------------------------------|-----------|----------------|
| Address(H)   | Address(D)  | Parameters                     | Data Type | Type of Access |
| 7C76H~7C78H  | 31862~31864 | The 3rd holiday and schedule   | Word      | R/W            |
| 7C79H~7C7BH  | 31865~31867 | The 4th holiday and schedule   | Word      | R/W            |
| 7C7CH~7C7EH  | 31868~31870 | The 5th holiday and schedule   | Word      | R/W            |
| 7C7FH~7C81H  | 31871~31873 | The 6th holiday and schedule   | Word      | R/W            |
| 7C82H~7C84H  | 31874~31876 | The 7th holiday and schedule   | Word      | R/W            |
| 7C85H~7C87H  | 31877~31879 | The 8th holiday and schedule   | Word      | R/W            |
| 7C88H~7C8AH  | 31880~31882 | The 9th holiday and schedule   | Word      | R/W            |
| 7C8BH~7C8DH  | 31883~31885 | The 10th holiday and schedule  | Word      | R/W            |
| 7C8EH~7C90H  | 31886~31888 | The 11th holiday and schedule  | Word      | R/W            |
| 7C91H~7C93H  | 31889~31891 | The 12th holiday and schedule  | Word      | R/W            |
| 7C94H~7C96H  | 31892~31894 | The 13th holiday and schedule  | Word      | R/W            |
| 7C97H~7C99H  | 31895~31897 | The 14th holiday and schedule  | Word      | R/W            |
| 7C3EH~7C40H  | 31898~31900 | The 15th holiday and schedule  | Word      | R/W            |
| 7C9DH~7C9FH  | 31901~31903 | The 16th holiday and schedule  | Word      | R/W            |
| 7CA0H~7CA2H  | 31904~31906 | The 17th holiday and schedule  | Word      | R/W            |
| 7CA3H~7CA5H  | 31907~31909 | The 18th holiday and schedule  | Word      | R/W            |
| 7CA6H~7CA8H  | 31910~31912 | The 19th holiday and schedule  | Word      | R/W            |
| 7CA9H~7CABH  | 31913~31915 | The 20th holiday and schedule  | Word      | R/W            |
| 7CACH~7CAEH  | 31916~31918 | The 21st holiday and schedule  | Word      | R/W            |
| 7CAFH~7CB1H  | 31919~31921 | The 22nd holiday and schedule  | Word      | R/W            |
| 7CB2H~7CB4H  | 31922~31924 | The 23rd holiday and schedule  | Word      | R/W            |
| 7CB5H~7CB7H  | 31925~31927 | The 24th holiday and schedule  | Word      | R/W            |
| 7CB8H~7CBAH  | 31928~31930 | The 25th holiday and schedule  | Word      | R/W            |
| 7CBBH~7CBDH  | 31931~31933 | The 26th holiday and schedule  | Word      | R/W            |
| 7CBEH~7CC0H  | 31934~31936 | The 27th holiday and schedule  | Word      | R/W            |
| 7CC1H~7CC3H  | 31937~31939 | The 28th holiday and schedule  | Word      | R/W            |
| 7CC4H~7CC6H  | 31940~31942 | The 29th holiday and schedule  | Word      | R/W            |
| 7CC7H~7CC9H  | 31943~31945 | The 30th holiday and schedule  | Word      | R/W            |
| 7CCAH  | 31946       | The 5th setting year           | Word      | R/W            |
| 7CCBH  | 31947       | Holiday number of the 5th year | Word      | R/W            |

Table 6-71

| The 6th Year Holiday Address Function: 03H Read 10H Preset |             |   |           |                |
|--|-------------|---|-----------|----------------|
| Address(H)   | Address(D)  | Parameters  | Data Type | Type of Access |
| 7CCCH~7CCEH  | 31948~31950 | The 1st holiday and schedule (format: month/day/schedule) | Word      | R/W            |
| 7CCFH~7CD1H  | 31951~31953 | The 2nd holiday and schedule                              | Word      | R/W            |
| 7CD2H~7CD4H  | 31954~31956 | The 3rd holiday and schedule                              | Word      | R/W            |
| 7CD5H~7CD7H  | 31957~31959 | The 4th holiday and schedule                              | Word      | R/W            |
| 7CD8H~7CDAH  | 31960~31962 | The 5th holiday and schedule                              | Word      | R/W            |
| 7CDBH~7CDDH  | 31963~31965 | The 6th holiday and schedule                              | Word      | R/W            |
| 7CDEH~7CE0H  | 31966~31968 | The 7th holiday and schedule                              | Word      | R/W            |
| 7CE1H~7CE3H  | 31969~31971 | The 8th holiday and schedule                              | Word      | R/W            |
| 7CD4H~7CE6H  | 31972~31974 | The 9th holiday and schedule                              | Word      | R/W            |
| 7CE7H~7CE9H  | 31975~31977 | The 10th holiday and schedule                             | Word      | R/W            |
| 7CEAH~7CECH  | 31978~31980 | The 11th holiday and schedule                             | Word      | R/W            |
| 7CEDH~7CEFH  | 31981~31983 | The 12th holiday and schedule                             | Word      | R/W            |
| 7CF0H~7CF2H  | 31984~31986 | The 13th holiday and schedule                             | Word      | R/W            |
| 7CF3H~7CF5H  | 31987~31989 | The 14th holiday and schedule                             | Word      | R/W            |
| 7CF6H~7CF8H  | 31990~31992 | The 15th holiday and schedule                             | Word      | R/W            |
| 7CF9H~7CFBH  | 31993~31995 | The 16th holiday and schedule                             | Word      | R/W            |
| 7CFCH~7CFEH  | 31996~31998 | The 17th holiday and schedule                             | Word      | R/W            |
| 7CFFH~7D01H  | 31999~32001 | The 18th holiday and schedule                             | Word      | R/W            |
| 7D02H~7D04H  | 32002~32004 | The 19th holiday and schedule                             | Word      | R/W            |
| 7D05H~7D07H  | 32005~32007 | The 20th holiday and schedule                             | Word      | R/W            |
| 7D08H~7D0AH  | 32008~32010 | The 21st holiday and schedule                             | Word      | R/W            |
| 7DOBH~7D0DH  | 32011~32013 | The 22nd holiday and schedule                             | Word      | R/W            |
| 7D0EH~7D10H  | 32014~32016 | The 23rd holiday and schedule                             | Word      | R/W            |
| 7D11H~7D13H  | 32017~32019 | The 24th holiday and schedule                             | Word      | R/W            |
| 7D14H~7D16H  | 32020~32022 | The 25th holiday and schedule                             | Word      | R/W            |
| 7D17H~7D19H  | 32023~32025 | The 26th holiday and schedule                             | Word      | R/W            |
| 7D1AH~7D1CH  | 32026~32028 | The 27th holiday and schedule                             | Word      | R/W            |
| 7D1DH~7D1FH  | 32029~32031 | The 28th holiday and schedule                             | Word      | R/W            |
| 7D20H~7D22H  | 32032~32034 | The 29th holiday and schedule                             | Word      | R/W            |

| The 6th Year Holiday Address Function: 03H Read 10H Preset |             |                                |           |                |
|--|-------------|--------------------------------|-----------|----------------|
| Address(H)   | Address(D)  | Parameters                     | Data Type | Type of Access |
| 7D23H~7D25H  | 32035~32037 | The 30th holiday and schedule  | Word      | R/W            |
| 7D26H  | 32038       | The 6th setting year           | Word      | R/W            |
| 7D27H  | 32039       | Holiday number of the 6th year | Word      | R/W            |

Table 6-72

| The 7th Year Holiday Address Function: 03H Read 10H Preset |             |  |           |                |
|--|-------------|--|-----------|----------------|
| Address(H)   | Address(D)  | Parameters   | Data Type | Type of Access |
| 7D28H~7D2AH  | 32040~32042 | The 1st holiday and schedule<br>(format: month/day/schedule) | Word      | R/W            |
| 7D2BH~7D2DH  | 32043~32045 | The 2nd holiday and schedule                                 | Word      | R/W            |
| 7D2EH~7D30H  | 32046~32048 | The 3rd holiday and schedule                                 | Word      | R/W            |
| 7D31H~7D33H  | 32049~32051 | The 4th holiday and schedule                                 | Word      | R/W            |
| 7D4H~7D36H   | 32052~32054 | The 5th holiday and schedule                                 | Word      | R/W            |
| 7D37H~7D39H  | 32055~32057 | The 6th holiday and schedule                                 | Word      | R/W            |
| 7D3AH~7D3CH  | 32058~32060 | The 7th holiday and schedule                                 | Word      | R/W            |
| 7D3DH~7D3FH  | 32061~32063 | The 8th holiday and schedule                                 | Word      | R/W            |
| 7D40H~7D42H  | 32064~32066 | The 9th holiday and schedule                                 | Word      | R/W            |
| 7D43H~7D45H  | 32067~32069 | The 10th holiday and schedule                                | Word      | R/W            |
| 7D46H~D48H   | 32070~32072 | The 11th holiday and schedule                                | Word      | R/W            |
| 7D49H~D4BH   | 32073~32075 | The 12th holiday and schedule                                | Word      | R/W            |
| 7D4CH~D4EH   | 32076~32078 | The 13th holiday and schedule                                | Word      | R/W            |
| 7D4FH~D51H   | 32079~32081 | The 14th holiday and schedule                                | Word      | R/W            |
| 7D52H~7D54H  | 32082~32084 | The 15th holiday and schedule                                | Word      | R/W            |
| 7D55H~7D57H  | 32085~32087 | The 16th holiday and schedule                                | Word      | R/W            |
| 7D58H~7D5AH  | 32088~32090 | The 17th holiday and schedule                                | Word      | R/W            |
| 7D5BH~7D5DH  | 32091~32093 | The 18th holiday and schedule                                | Word      | R/W            |
| 7DFEH~7D60H  | 32094~32096 | The 19th holiday and schedule                                | Word      | R/W            |
| 7D61H~7D63H  | 32097~32099 | The 20th holiday and schedule                                | Word      | R/W            |
| 7D64H~7D66H  | 32100~32102 | The 21st holiday and schedule                                | Word      | R/W            |
| 7D67H~7D69H  | 32103~32105 | The 22nd holiday and schedule                                | Word      | R/W            |

| The 7th Year Holiday Address Function: 03H Read 10H Preset |             |                                |           |                |
|--|-------------|--------------------------------|-----------|----------------|
| Address(H)   | Address(D)  | Parameters                     | Data Type | Type of Access |
| 7D6AH~7D6CH  | 32106~32108 | The 23rd holiday and schedule  | Word      | R/W            |
| 7D6DH~7D6FH  | 32109~32111 | The 24th holiday and schedule  | Word      | R/W            |
| 7D70H~7D72H  | 32112~32117 | The 25th holiday and schedule  | Word      | R/W            |
| 7D73H~7D75H  | 32115~32117 | The 26th holiday and schedule  | Word      | R/W            |
| 7D76H~7D78H  | 32118~32120 | The 27th holiday and schedule  | Word      | R/W            |
| 7D79H~7D7BH  | 32121~32123 | The 28th holiday and schedule  | Word      | R/W            |
| 7D7CH~7D7EH  | 32124~32126 | The 29th holiday and schedule  | Word      | R/W            |
| 7D7FH~7D81H  | 32127~32129 | The 30th holiday and schedule  | Word      | R/W            |
| 7D82H  | 32130       | The 7th setting year           | Word      | R/W            |
| 7D83H  | 32131       | Holiday number of the 7th year | Word      | R/W            |

Table 6-73

| The 8th Year Holiday Address Function: 03H Read 10H Preset |             |  |           |                |
|--|-------------|--|-----------|----------------|
| Address(H)   | Address(D)  | Parameters   | Data Type | Type of Access |
| 7D84H~7D86H  | 32132~32134 | The 1st holiday and schedule<br>(format: month/day/schedule) | Word      | R/W            |
| 7D87H~7D89H  | 32135~32137 | The 2nd holiday and schedule                                 | Word      | R/W            |
| 7D8AH~7D8CH  | 32138~32140 | The 3rd holiday and schedule                                 | Word      | R/W            |
| 7D8DH~7D8FH  | 32141~32143 | The 4th holiday and schedule                                 | Word      | R/W            |
| 7D90H~7D92H  | 32144~32146 | The 5th holiday and schedule                                 | Word      | R/W            |
| 7D93H~7D95H  | 32147~32149 | The 6th holiday and schedule                                 | Word      | R/W            |
| 7D96H~7D98H  | 32150~32152 | The 7th holiday and schedule                                 | Word      | R/W            |
| 7D99H~7D9BH  | 32153~32155 | The 8th holiday and schedule                                 | Word      | R/W            |
| 7D9CH~7D9EH  | 32156~32158 | The 9th holiday and schedule                                 | Word      | R/W            |
| 7D9FH~7DA1H  | 32159~32161 | The 10th holiday and schedule                                | Word      | R/W            |
| 7DA2H~7DA4H  | 32162~32164 | The 11th holiday and schedule                                | Word      | R/W            |
| 7DA5H~7DA7H  | 32165~32167 | The 12th holiday and schedule                                | Word      | R/W            |
| 7DA8H~7DAAH  | 32168~32170 | The 13th holiday and schedule                                | Word      | R/W            |
| 7DABH~7DADH  | 32171~32173 | The 14th holiday and schedule                                | Word      | R/W            |
| 7DAEH~7DB0H  | 32174~32176 | The 15th holiday and schedule                                | Word      | R/W            |

| The 8th Year Holiday Address Function: 03H Read 10H Preset |             |                                |           |                |
|--|-------------|--------------------------------|-----------|----------------|
| Address(H)   | Address(D)  | Parameters                     | Data Type | Type of Access |
| 7DB1H~7DB3H  | 32177~32179 | The 16th holiday and schedule  | Word      | R/W            |
| 7DB4H~7DB6H  | 32180~32182 | The 17th holiday and schedule  | Word      | R/W            |
| 7DB7H~7DB9H  | 32183~32185 | The 18th holiday and schedule  | Word      | R/W            |
| 7DBAH~7DBCH  | 32186~32188 | The 19th holiday and schedule  | Word      | R/W            |
| 7DBDH~7DBFH  | 32189~32191 | The 20th holiday and schedule  | Word      | R/W            |
| 7DC0H~7DC2H  | 32192~32194 | The 21st holiday and schedule  | Word      | R/W            |
| 7DC3H~7DC5H  | 32195~32197 | The 22nd holiday and schedule  | Word      | R/W            |
| 7DC6H~7DC8H  | 32198~32200 | The 23rd holiday and schedule  | Word      | R/W            |
| 7DC9H~7DCBH  | 32201~32203 | The 24th holiday and schedule  | Word      | R/W            |
| 7DCCH~7DCEH  | 32204~32206 | The 25th holiday and schedule  | Word      | R/W            |
| 7DCFH~7DD1H  | 32207~32209 | The 26th holiday and schedule  | Word      | R/W            |
| 7DD2H~7DD4H  | 32210~32212 | The 27th holiday and schedule  | Word      | R/W            |
| 7DD5H~7DD7H  | 32213~32215 | The 28th holiday and schedule  | Word      | R/W            |
| 7DD8H~7DDAH  | 32216~32218 | The 29th holiday and schedule  | Word      | R/W            |
| 7DDBH~7DDDH  | 32219~32221 | The 30th holiday and schedule  | Word      | R/W            |
| 7DDEH  | 32222       | The 8th setting year           | Word      | R/W            |
| 7DDFH  | 32223       | Holiday number of the 8th year | Word      | R/W            |

Table 6-74

| The 9th Year Holiday Address Function: 03H Read 10H Preset |             |  |           |                |
|--|-------------|--|-----------|----------------|
| Address(H)   | Address(D)  | Parameters   | Data Type | Type of Access |
| 7DE0H~7DE2H  | 32224~32226 | The 1st holiday and schedule<br>(format: month/day/schedule) | Word      | R/W            |
| 7DE3H~7DE5H  | 32227~32229 | The 2nd holiday and schedule                                 | Word      | R/W            |
| 7DE6H~7DE8H  | 32230~32232 | The 3rd holiday and schedule                                 | Word      | R/W            |
| 7DE9H~7DEBH  | 32233~32235 | The 4th holiday and schedule                                 | Word      | R/W            |
| 7DECH~7DEEH  | 32236~32238 | The 5th holiday and schedule                                 | Word      | R/W            |
| 7DEFH~7DF1H  | 32239~32241 | The 6th holiday and schedule                                 | Word      | R/W            |
| 7DF2H~7DF4H  | 32242~32244 | The 7th holiday and schedule                                 | Word      | R/W            |
| 7DF5H~7DF7H  | 32245~32247 | The 8th holiday and schedule                                 | Word      | R/W            |

| The 9th Year Holiday Address Function: 03H Read 10H Preset |             |                                |           |                |
|--|-------------|--------------------------------|-----------|----------------|
| Address(H)   | Address(D)  | Parameters                     | Data Type | Type of Access |
| 7DF8H~7DFAH  | 32248~32250 | The 9th holiday and schedule   | Word      | R/W            |
| 7DFBH~7DFDH  | 32251~32253 | The 10th holiday and schedule  | Word      | R/W            |
| 7DFEH~7E00H  | 32254~32256 | The 11th holiday and schedule  | Word      | R/W            |
| 7E01H~7E03H  | 32257~32259 | The 12th holiday and schedule  | Word      | R/W            |
| 7E04H~7E06H  | 32260~32262 | The 13th holiday and schedule  | Word      | R/W            |
| 7E07H~7E09H  | 32263~32265 | The 14th holiday and schedule  | Word      | R/W            |
| 7E0AH~7E0CH  | 32266~32268 | The 15th holiday and schedule  | Word      | R/W            |
| 7E0DH~7E0FH  | 32269~32271 | The 16th holiday and schedule  | Word      | R/W            |
| 7E10H~7E12H  | 32272~32274 | The 17th holiday and schedule  | Word      | R/W            |
| 7E13H~7E15H  | 32275~32277 | The 18th holiday and schedule  | Word      | R/W            |
| 7E16H~7E18H  | 32278~32280 | The 19th holiday and schedule  | Word      | R/W            |
| 7E19H~7E1BH  | 32281~32283 | The 20th holiday and schedule  | Word      | R/W            |
| 7E1CH~7E1EH  | 32284~32286 | The 21st holiday and schedule  | Word      | R/W            |
| 7E1FH~7E21H  | 32287~32289 | The 22nd holiday and schedule  | Word      | R/W            |
| 7E22H~7E24H  | 32290~32292 | The 23rd holiday and schedule  | Word      | R/W            |
| 7E25H~7E27H  | 32293~32295 | The 24th holiday and schedule  | Word      | R/W            |
| 7E28H~7E2AH  | 32296~32298 | The 25th holiday and schedule  | Word      | R/W            |
| 7E2BH~7E2DH  | 32299~32301 | The 26th holiday and schedule  | Word      | R/W            |
| 7E2EH~7E30H  | 32302~32304 | The 27th holiday and schedule  | Word      | R/W            |
| 7E31H~7E33H  | 32305~32307 | The 28th holiday and schedule  | Word      | R/W            |
| 7E34H~7E36H  | 32308~32310 | The 29th holiday and schedule  | Word      | R/W            |
| 7E37H~7E39H  | 32311~32313 | The 30th holiday and schedule  | Word      | R/W            |
| 7E3AH  | 32314       | The 9th setting year           | Word      | R/W            |
| 7E3BH  | 32315       | Holiday number of the 9th year | Word      | R/W            |

Table 6-75

| The 10th Year Holiday Address Function: 03H Read 10H Preset |             |  |           |                |
|---|-------------|--|-----------|----------------|
| Address(H)  | Address(D)  | Parameters   | Data Type | Type of Access |
| 7E3CH~7E3EH   | 32316~32318 | The 1st holiday and schedule<br>(format: month/day/schedule) | Word      | R/W            |
| 7E3FH~7E41H   | 32319~32321 | The 2nd holiday and schedule                                 | Word      | R/W            |

## Acuvim II Series Power Meter

| The 10th Year Holiday Address Function: 03H Read 10H Preset |             |                                 |           |                |
|---|-------------|---------------------------------|-----------|----------------|
| Address(H)  | Address(D)  | Parameters                      | Data Type | Type of Access |
| 7E42H~7E44H   | 32322~32324 | The 3rd holiday and schedule    | Word      | R/W            |
| 7E45H~7E47H   | 32325~32327 | The 4th holiday and schedule    | Word      | R/W            |
| 7E48H~7E4AH   | 32328~32330 | The 5th holiday and schedule    | Word      | R/W            |
| 7E4BH~7E4DH   | 32331~32333 | The 6th holiday and schedule    | Word      | R/W            |
| 7E4EH~7E50H   | 32334~32336 | The 7th holiday and schedule    | Word      | R/W            |
| 7E51H~7E53H   | 32337~32339 | The 8th holiday and schedule    | Word      | R/W            |
| 7E54H~7E56H   | 32340~32342 | The 9th holiday and schedule    | Word      | R/W            |
| 7E57H~7E59H   | 32343~32345 | The 10th holiday and schedule   | Word      | R/W            |
| 7E5AH~7E5CH   | 32346~32348 | The 11th holiday and schedule   | Word      | R/W            |
| 7E5DH~7E5FH   | 32349~32351 | The 12th holiday and schedule   | Word      | R/W            |
| 7E60H~7E62H   | 32352~32354 | The 13th holiday and schedule   | Word      | R/W            |
| 7E63H~7E65H   | 32355~32357 | The 14th holiday and schedule   | Word      | R/W            |
| 7E66H~7E68H   | 32358~32360 | The 15th holiday and schedule   | Word      | R/W            |
| 7E69H~7E6BH   | 32361~32363 | The 16th holiday and schedule   | Word      | R/W            |
| 7E6CH~7E6EH   | 32364~32366 | The 17th holiday and schedule   | Word      | R/W            |
| 7E6FH~7E71H   | 32367~32369 | The 18th holiday and schedule   | Word      | R/W            |
| 7E72H~7E74H   | 32370~32372 | The 19th holiday and schedule   | Word      | R/W            |
| 7E75H~7E77H   | 32373~32375 | The 20th holiday and schedule   | Word      | R/W            |
| 7E78H~7E7AH   | 32376~32378 | The 21st holiday and schedule   | Word      | R/W            |
| 7E7BH~7E7DH   | 32379~32381 | The 22nd holiday and schedule   | Word      | R/W            |
| 7E7EH~7E80H   | 32382~32384 | The 23rd holiday and schedule   | Word      | R/W            |
| 7E81H~7E83H   | 32385~32387 | The 24th holiday and schedule   | Word      | R/W            |
| 7E84H~7E86H   | 32388~32390 | The 25th holiday and schedule   | Word      | R/W            |
| 7E87H~7E89H   | 32391~32393 | The 26th holiday and schedule   | Word      | R/W            |
| 7E8AH~7E8CH   | 32394~32396 | The 27th holiday and schedule   | Word      | R/W            |
| 7E8DH~7E8FH   | 32397~32399 | The 28th holiday and schedule   | Word      | R/W            |
| 7E90H~7E92H   | 32400~32402 | The 29th holiday and schedule   | Word      | R/W            |
| 7E93H~7E95H   | 32403~32405 | The 30th holiday and schedule   | Word      | R/W            |
| 7E96H   | 32406       | The 10th setting year           | Word      | R/W            |
| 7E97H   | 32407       | Holiday number of the 10th year | Word      | R/W            |

Table 6-76

| Address(H) | Address(H) | Parameters                         | Data Type | Property | Range  | Default | Factory Setting |
|------------|------------|------------------------------------|-----------|----------|--|---------|-----------------|
| 8000H      | 32768      | Manual triggering waveform         | Word      | R/W      | 0xAA: Enable<br>0: Disable   | 0       | 0               |
| 8001H      | 32769      | D1 triggering – AXM-11             | Word      | R/W      | bit1bit0: DI1, bit3bit2: DI2, bit5bit4: DI3, bit7bit6: DI4, bit9bit8: DI5, bit11bit10: DI6, 00: Disable; 00: From OFF to ON; 10: From ON to OFF; 11: Any DI state change | 0       | 0               |
| 8002H      | 32770      | DI triggering – AXM-21             | Word      | R/W      | bit1bit0: DI7, bit3bit2: DI8, bit5bit4: DI9, bit7bit6: DI10; The same as above   | 0       | 0               |
| 8003H      | 32771      | DI triggering – AXM-31             | Word      | R/W      | Bit1bit0: DI11, bit3bit2: DI12, bit5bit4: DI13, bit7bit6: DI14; The same as above  | 0       | 0               |
| 8004H      | 32772      | Voltage rated value                | Word      | R/W      | 50V-400V or 50V-690V (only in 3LL)   | 400     | 400             |
| 8005H      | 32773      | Voltage sag triggering waveform    | Word      | R/W      | 1: Enable, 0: Disable  | 0       | 0               |
| 8006H      | 32774      | Voltage sag threshold              | Word      | R/W      | 20-100%  | 10      | 10              |
| 8007H      | 32775      | Voltage sag half cycle threshold   | Word      | R/W      | 4-200 half cycles  | 0       | 0               |
| 8008H      | 32776      | Voltage swell triggering threshold | Word      | R/W      | 1: Enable, 0: Disable  | 100     | 100             |
| 8009H      | 32777      | Voltage swell threshold            | Word      | R/W      | 50-140%  |         |                 |
| 800AH      | 32778      | Reserved                           | Word      | R/W      |  | 5000    | 5000            |
| 800BH      | 32779      | Current rated value                | Word      | R/W      | 1: Enable, 0: Disable  |         |                 |
| 800CH      | 32780      | Over-current triggering waveform   | Word      | R/W      | 1: Enable, 0: Disable  | 0       | 0               |
| 800DH      | 32781      | Over-current threshold             | Word      | R/W      | 50-150%  | 100     | 100             |
| 800EH      | 32782      | Clear waveform                     | Word      | R/W      | 0x55 enable  | 0       | 0               |
| 800FH      | 32783      | Clear power quality event          | Word      | R/W      | 0x55 enable  | 0       | 0               |

**NOTE:** In 3LL and 2LL, voltage rated value is line voltage; in 3LN, 1LN and 1LL, voltage rated value is phase voltage.

Waveform Capture Data Retrieve Address

Waveform Capture includes timestamp, triggering condition, and waveform data. Every group uses

## Acuvim II Series Power Meter

the same data format. Only one group of waveforms is saved in the registers. When retrieving the waveform, first write 1-8 group number into 0X801FH, then read the registers after it to acquire the waveform corresponding to the written group number.

The relationship between voltage waveform value and real value:

$$\text{Real Value (Unit: V)} = \text{Waveform Value} / 37.59105$$

The relationship between current waveform value and real value:

1. 5A, 1A: Real Value (Unit: A) = Waveform Value/1683.153;
2. 333mV: Real Value (Unit: A) = Waveform Value/K (firmware above 3.21,K=14427.15; other: K = 15869.87);
3. 100mV(Rope-CT): Real Value(Unit: A) = Waveform Value/K (firmware above 3.21,K=20291.1; firmware 3.20, K=22068.8,other: K = 15869.87);
4. mA CT: Real Value(Unit: A) = Waveform Value/K (80mA CT: K=7414.289; 100mA: K=9267.440; 200mA: K=18514.68 );

The voltage and current value obtained from the waveform are the PT or CT secondary side value.

Read: 03, Preset: 10. For more information, please refer to Chapter 4.7.

Table 6-77

| Address (H) | Address (D) | Parameter                              | Default | Range   | Data Type | Property |
|-------------|-------------|--|---------|---|-----------|----------|
| 8E00H       | 36352       | Waveform group number for retrieving   |         | 1~100<br>When the value is smaller than or equal to newest waveform record group number, this value is valid              | Word      | R/W      |
| 8E01H       | 36353       | Waveform group number                  |         | Waveform number 0-121   | Word      | R/W      |
| 8E02H       | 36354       | Waveform record window status          |         | 0x0BH: Window data is valid<br>0xFF: Window data is invalid<br>0xAA: Waveform record memory is clearing (data is invalid) | Word      | R/W      |
| 8E03H       | 36355       | Newest waveform group number           |         | 1~100 0: No record  | Word      | R/W      |
| 8E04H~8E43  | 36356~36419 | Waveform record data retrieving window |         | -32768~32767  | Word      | R/W      |

**Power Quality Event Retrieve Address**

Power quality event includes timestamp, triggering condition, and related settings. Every group uses the same data format. Only 10 groups of data are saved in the registers. When retrieving the event data, its parameters must be correctly set in order to get correct information.

Read: FC03, Preset: FC16. For more information, please refer to Chapter 4.7.

**Table 6-78**

| Address(H)         | Address(H)      | Parameters   | Data Type | Property | Range   | Default | Factory Setting |
|--------------------|-----------------|--|-----------|----------|---|---------|-----------------|
| 8CFDH              | 36093           | Newest event group number                            | Word      | R        | 1-50000 0: No data  | 0       | 0               |
| 8CFEH              | 36094           | Event for retrieving starting group number           | Word      | R/W      | 1-50000<br>Only valid smaller or equal to newest event group number | 1       | 1               |
| <b>No. 1 Event</b> |                 |  |           |          |   |         |                 |
| 8D00H              | 36096           | Timestamp<br>High byte – Year<br>Low byte – Month    | Word      | R        | Time  |         |                 |
| 8D01H              | 36097           | Timestamp<br>High byte – Day<br>Low byte – Hour      | Word      | R        | Time  |         |                 |
| 8D02H              | 36098           | Timestamp<br>High byte – Minute<br>Low byte – Second | Word      | R        | Time  |         |                 |
| 8D03H              | 36099           | Timestamp:<br>Millisecond                            | Word      | R        | Time  |         |                 |
| 8D04H              | 36100           | Voltage sag or voltage swell condition               | Word      | R        | 0: Disabled, 1: Voltage sag, 2: Voltage swell                       |         |                 |
| 8D05H              | 36101           | Rated value  | Word      | R        | 50V~400V or 50V~690V (only in 3LL)                                  |         |                 |
| 8D06H              | 36102           | Threshold  | Word      | R        | Voltage sag: 20-100%,<br>Voltage swell: 50-140%                     |         |                 |
| 8D07H              | 36103           | Half cycle count                                     | Word      | R        | Voltage sag event: 4~200;<br>Voltage swell event: 0                 |         |                 |
| 8D08H~<br>8D0FH    | 36104~<br>36111 | No. 2 Event  | Word      | R        |   |         |                 |
| 8D10H~<br>8D17H    | 36112~<br>36119 | No. 3 Event  | Word      | R        |   |         |                 |
| 8D18H~<br>8D1FH    | 36120~<br>36127 | No. 4 Event  | Word      | R        |   |         |                 |

## Acuvim II Series Power Meter

---

| Address(H)      | Address(H)      | Parameters   | Data Type | Property | Range | Default | Factory Setting |
|-----------------|-----------------|--------------|-----------|----------|-------|---------|-----------------|
| 8D20H~<br>8D27H | 36128~<br>36135 | No. 5 Event  | Word      | R        |       |         |                 |
| 8D28H~<br>8D2FH | 36136~<br>36143 | No. 6 Event  | Word      | R        |       |         |                 |
| 8D30H~<br>8D37H | 36144~<br>36151 | No. 7 Event  | Word      | R        |       |         |                 |
| 8D38H~<br>8D3FH | 36152~<br>36159 | No. 8 Event  | Word      | R        |       |         |                 |
| 8D40H~<br>8D47H | 36160~<br>36167 | No. 9 Event  | Word      | R        |       |         |                 |
| 8D48H~<br>8D4FH | 36168~<br>36175 | No. 10 Event | Word      | R        |       |         |                 |

## Appendix

### Appendix A Technical Data and Specification

#### Input Ratings

##### CURRENT INPUTS (EACH CHANNEL)

|                         |   |
|-------------------------|---|
| Nominal Current Options | ① 5A, ② 1A, ③ 1A (333mV)<br>④ 1A (100mV Rope CT)<br>⑤ 1A (80mA/100mA/200mA) |
| Metering Range          | ① 0-10A, ② 0-2A, ③ 0-1.2A,<br>④ 0-1.2A, ⑤ 0-1.2A                            |
| Pickup Current          | ① 5mA, ② 1mA, ③ 5mA, ④ 5mA, ⑤ 5mA   |
| Withstand               | 20Arms Continuous, 0.1% of Nominal<br>100Arms for 1 second, Non-Recurring   |
| Burden                  | 0.05VA (Typical) @ 5A RMS   |
| Accuracy                | 0.1% at Reading   |

##### VOLTAGE INPUTS (EACH CHANNEL)

|                    |   |
|--------------------|---|
| Nominal Full Scale | 400Vac L-N, 690Vac L-L (+20%)                       |
| Withstand          | 1500Vac Continuous<br>2500Vac, 50/60Hz for 1 Minute |
| Input Impedance    | 2M $\Omega$ per Phase                               |
| Metering Frequency | 45Hz~65Hz, 300Hz~500Hz                              |
| Pickup Voltage     | 10Vac   |
| Accuracy           | 0.1% at Reading                                     |

##### ENERGY ACCURACY

|          |  |
|----------|--|
| Active   | Class 0.1s (According to IEC 62053-22)<br>Class 0.1 (According to ANSI C12.20) |
| Reactive | Class 2 (According to IEC 62053-23)  |

##### HARMONIC RESOLUTION

|               |   |
|---------------|---|
| Metered Value | 63rd Harmonic (50Hz or 60Hz type)<br>15th Harmonic (400Hz type) |
|---------------|---|

## Acuvim II Series Power Meter

### Metering

| PARAMETERS                     |           | ACCURACY | RESOLUTION | RANGE   |
|--------------------------------|-----------|----------|------------|---|
| Voltage                        |           | 0.1%     | 0.1V       | 10V~1000kV  |
| Current                        |           | 0.1%     | 0.1mA      | 5mA~5000A   |
| Power                          |           | 0.1%     | 1W         | -9999MW~9999MW  |
| Reactive Power                 |           | 0.1%     | 1var       | -9999Mvar~9999Mvar  |
| Apparent Power                 |           | 0.1%     | 1VA        | 0~9999MVA   |
| Power Demand                   |           | 0.1%     | 1W         | -9999MW~9999MW  |
| Reactive Power Demand          |           | 0.1%     | 1var       | -9999Mvar~9999Mvar  |
| Apparent Power Demand          |           | 0.1%     | 1VA        | 0~9999MVA   |
| Power Factor                   |           | 0.1%     | 0.001      | -1.000~1.000  |
| Frequency                      |           | 0.001%   | 0.001Hz    | 45.00~65.00Hz (50 or 60Hz type)<br>300.00Hz~500.00Hz (400Hz type) |
| Energy                         | Primary   | 0.1%     | 0.1kWh     | 0-99999999.9kWh   |
|                                | Secondary | 0.1%     | 0.001kWh   | 0-999999.999kWh   |
| Reactive Energy                | Primary   | 0.1%     | 0.1kvarh   | 0-99999999.9kvarh   |
|                                | Secondary | 0.1%     | 0.001kvarh | 0-999999.999kvarh   |
| Apparent Energy                | Primary   | 0.1%     | 0.1kVAh    | 0-99999999.9kVAh  |
|                                | Secondary | 0.1%     | 0.001kVAh  | 0-999999.999kVAh  |
| Harmonics                      |           | 1.0%     | 0.1%       |   |
| Phase Angle                    |           | 2.0%     | 0.1°       | 0.0°~359.9°   |
| Unbalance Factor Stay The Same |           | 2.0%     | 0.1%       | 0.0%~100.0%   |
| Running Time                   |           |          | 0.01h      | 0~9999999.99h   |

### Control Power

Universal AC or DC

#### AC/DC CONTROL POWER

|                 |   |
|-----------------|---|
| Operating Range | 100~415Vac, 50/60Hz; 100~300Vdc   |
| Burden          | 5W  |
| Frequency       | 50/60Hz   |
| Withstand       | 3250Vac, 50/60Hz for 1 minute<br>Installation Category III (Distribution) |

#### LOW VOLTAGE DC CONTROL POWER (OPTIONAL)

|                 |          |
|-----------------|----------|
| Operating Range | 20~60Vdc |
| Burden          | 5W       |

**I/O Options****DIGITAL INPUT**

|                       |  |
|-----------------------|--|
| Input Type            | Dry  |
| Input Resistance      | 100k $\Omega$                              |
| Input Voltage Range   | 20–160 Vac/dc                              |
| Input Current (Max)   | 2mA  |
| Start Voltage         | 15V  |
| Stop Voltage          | 5V   |
| Pulse Frequency (Max) | 100Hz, 50% Duty Ratio (5ms ON and 5ms OFF) |
| SOE Resolution        | 2ms  |

**DIGITAL OUTPUT (DO) (PHOTO-MOS)**

|                   |  |
|-------------------|--|
| Voltage Range     | 0–250Vac/dc                              |
| Load Current      | 100mA (Max)                              |
| Output Frequency  | 25Hz, 50% Duty Ratio (20ms ON, 20ms OFF) |
| Isolation Voltage | 2500Vac                                  |

**RELAY OUTPUT (RO) (NO, Form A)**

|                         |                     |
|-------------------------|---------------------|
| Switching Voltage (Max) | 250Vac, 30Vdc       |
| Load Current            | 5A(R), 2A(L)        |
| Set Time                | 10ms (Max)          |
| Contact Resistance      | 30m $\Omega$ (Max)  |
| Isolation Voltage       | 2500Vac             |
| Mechanical Life         | 1.5x10 <sup>7</sup> |

**ANALOGUE OUTPUT (AO)**

|                      |                                      |
|----------------------|--------------------------------------|
| Output Range         | 0–5V, 0–20mA; 1–5V, 4–20mA; Optional |
| Accuracy             | 0.50%                                |
| Temperature Drift    | 50ppm/ $^{\circ}$ C Typical          |
| Isolation Voltage    | 500Vdc                               |
| Open Circuit Voltage | 15V                                  |

**ANALOGUE INPUT (AI)**

|                   |                                      |
|-------------------|--------------------------------------|
| Input Range       | 0–5V, 0–20mA; 1–5V, 4–20mA; Optional |
| Accuracy          | 0.20%                                |
| Temperature Drift | 50ppm/ $^{\circ}$ C Typical          |
| Isolation Voltage | 500Vdc                               |

**POWER SUPPLY FOR DI (24 VDC)**

|                |        |
|----------------|--------|
| Output Voltage | 24Vdc  |
| Output Current | 42mA   |
| Load (Max)     | 21 Dis |

## Acuvim II Series Power Meter

### Standard Compliance & Certifications

|                        |  |
|------------------------|--|
| Measurement Standard   | IEC 62053-22;<br>ANSI C12.20; IEC61557-12                                |
| Environmental Standard | IEC 60068-2, CE, RoHS  |
| Safety Standard        | IEC 61010-1, UL 61010-1  |
| EMC Standard           | IEC 61000-4/-2-3-4-5-6-8-11, CISPR 22,<br>IEC 61000-3-2, IEC 61000-6-2/4 |
| Outlines Standard      | DIN 43700, ANSI C39.1  |
| Protocol Conformance   | IEC 61850 2nd Edition<br>BTL Listed for B-SA (Acuvim IIR, IIW)           |

### Communications

|   |  |
|---|--|
| <b>Modbus-RTU<br/>or BACnet MS/TP</b>           | Modbus-RTU<br>2-Wire Shielded Twisted Pair Cable Connection<br>1200~115200 bps   |
| <b>SECOND RS-485 PORT (OPTIONAL<br/>MODULE)</b> | Same as the primary RS485 port<br>Baud Rate: 4800~38400 bps  |
| <b>ETHERNET<br/>(OPTIONAL MODULE)</b>           | Ethernet 10M/100M BaseT<br>MODBUS-TCP/IP<br>DNP 3.0 Over IP Level 2<br>IEC 61850 2nd Edition<br>SNMP V3<br>BACnet-IP<br>HTTP/HTTPs Webserver<br>HTTP/HTTPs, FTP data post<br>SMTP<br>MQTT<br>MV90<br>NTP                         |
| <b>PROFIBUS<br/>(OPTIONAL MODULE)</b>           | PROFIBUS-DP/V0 Protocol<br>Work as PROFIBUS Slave, Baud Rate Adaptive, up to<br>12M<br>Model 1: Input Bytes: 32, Output Bytes: 32<br>Model 2: Input Bytes: 64, Output Bytes: 2<br>PROFIBUS Standard According to EN 50170 Vol. 2 |

**Control Power**

|           |          |
|-----------|----------|
| Universal | AC or DC |
|-----------|----------|

**AC/DC CONTROL POWER**

|                 |   |
|-----------------|---|
| Operating Range | 100~415Vac, 50/60Hz; 100~300Vdc   |
| Burden          | 5W  |
| Frequency       | 50/60Hz   |
| Withstand       | 3250Vac, 50/60Hz for 1 minute<br>Installation Category III (Distribution) |

**LOW VOLTAGE DC CONTROL POWER (OPTIONAL)**

|                 |          |
|-----------------|----------|
| Operating Range | 20~60Vdc |
| Burden          | 5W       |

**Operating Environment**

|                       |                                 |
|-----------------------|---------------------------------|
| Operating Temperature | -25°C to 70°C<br>-13°F to 158°F |
| Storage Temperature   | -40°C to 85°C<br>-40°F to 176°F |
| Relative Humidity     | 5% to 95% Non-Condensing        |

## Acuvim II Series Power Meter

### Appendix B Ordering Information

| Meter Model  | Mounting Option  | Current Input   | Power Supply  |
|--|--|---|---|
| <b>Acuvim IIR:</b><br>Data Logging, TOU                              | <b>D:</b> LCD Display<br>(Panel Mount Meter/<br>Transducer)                                      | <b>5A:</b> 5A/1A<br>(Input Field Selectable)  | <b>P1V3:</b><br>100~415Vac,<br>50/60Hz,<br>100~300Vdc |
| <b>Acuvim IIW:</b><br>IIR + Waveform Capture<br>and PQ Event Logging | <b>M:</b> DIN-Rail Mount<br>Transducer without Display<br>(Optional Remote Display<br>Available) | <b>mV:</b> 333mV and<br>Rogowski Coil (Input<br>Field Selectable)<br><br><b>mA:</b><br>80ma/100mA/200mA<br>(Input Field Selectable) | <b>P2V3:</b> 20~60Vdc                                 |

**Ordering Example:** Acuvim IIR-D-5A-P1V3

- Note:
1. Accuenergy suggests using USB-RS485 converter for configuration, and 3 CTs per three phase circuits.
  2. All fields must be completed to create a part number.
  3. Add "S" after power supply for anti-tampering seal option.
  4. Contact Accuenergy for 400Hz frequency option; Acuvim IIW doesn't support this type.

| Communication Module (Optional) | Protocols  |
|---------------------------------|--|
| <b>AXM</b>                      | <b>WEB2-FOLC:</b> IEC 61850, Modbus-TCP, HTTP/HTTPS Webserver, SMTP Email, SNMP, HTTP/HTTPS Push, FTP Post, sFTP Server, BACnet-IP, Datalogging, WiFi, Fiber Optics LC |
|                                 | <b>WEB2:</b> IEC 61850, Modbus-TCP, HTTP/HTTPS Webserver, SMTP Email, SNMP, HTTP/HTTPS Push, FTP Post, sFTP Server, BACnet-IP, Datalogging, WiFi                       |
|                                 | <b>WEB-PUSH:</b> Modbus-TCP, HTTP/HTTPS Webserver, SMTP Email, SNMP, HTTP/HTTPS Push, FTP Post, sFTP Server, Datalogging   |
|                                 | <b>PROFI:</b> PROFIBUS   |
|                                 | <b>RS485:</b> Modbus-RTU   |
|                                 | <b>MESH-900:</b> Wireless Radio (900MHz)   |
|                                 | <b>MESH-868:</b> Wireless Radio (868MHz)   |

**Ordering Example:** AXM-RS485

| I/O Module (Optional)    | - Logic Module    | - Input/Output Type |
|--------------------------|-------------------|---------------------|
| AXM-IO1                  | 1                 |                     |
|                          | 2                 |                     |
| <b>Ordering Example:</b> | <b>AXM-IO1-1</b>  |                     |
| AXM-IO2                  | 1                 | A: 4~20mA           |
| AXM-IO3                  | 2                 | B: 0~20mA           |
|                          |                   | C: 1~5V             |
|                          |                   | D: 0~5V             |
| <b>Ordering Example:</b> | <b>AXM-IO3-1B</b> |                     |

#### Accessories (Optional)

|              |  |
|--------------|--|
| REM-DS2:     | Remote Display<br>(Only for Acuvim II DIN-Rail Mount "M" option) |
| AXM-DIN:     | DIN Rail Adapter   |
| IP66/NEMA4X: | Environmental Protection Cover                                   |
| USB-RS485:   | USB-to-RS485 Converter   |

**Ordering Example:** AXM-DIN

- Note:
1. Refer to the Communication table and Digital/Analogue I/O table on page 6.
  2. A maximum of 3 modules may be attached to the meter. If a communication module is used (e.g. AXM-WEB2), it must be installed on the back FIRST before the other I/O modules are attached.
  3. No more than 2 of the same I/O modules may be attached to the meter (e.g. two AXM-IO2). The same two I/O modules must have a different logic number.
  4. If Acuvim IIW uses DI to trigger a waveform capture, the I/O module logic number must be Module 1.



MAKE ENERGY USAGE SMARTER

**ACCUEENERGY (CANADA) INC.**

22 Howden Rd  
Scarborough, ON M1R 3E4, Canada

TF: 1-877-721-8908  
INT: +1-416-497-4100  
FAX: +1-416-497-4130  
E: [marketing@accuenergy.com](mailto:marketing@accuenergy.com)

**ACCUEENERGY SOUTH AFRICA (PTY) LTD**

Castle Walk Corporate Park,  
Block B, Cnr. Nossob & Swakop Street  
Erasmuskloof, Pretoria, 0181  
South Africa

TF: +27 (0) 87 802 6136



Revision Date: November 2022