

Current Transformers

Submetering Solutions for Accurate Measurement & Verification



DEFINITION

Leviton Current Transformers (CTs) support our full line of VerifEye™ revenue-grade meters and help meet all measurement and verification-based opportunities—including smart metering and LEED rating achievement. Designed as part of a simple and effective process for accurately capturing measurements of power consumption, CTs are easy to specify and install for new construction and retrofits.

The better the equipment, the better the measurement. Leviton meters utilize highly accurate current transformers for revenue-grade performance certified to ANSI standards. Competing products use current sensors that do not provide the same level of performance. CTs come as solid core standard for high-quality, long-term accuracy and reliability. Solid core CTs deliver +/-0.3% accuracy. Split core and Rogowski Coil CTs deliver +/-1.0% accuracy. For added safety, all Leviton current transformers come with built-in voltage suppression devices that prevent hazardous voltages from developing on CT secondaries should they become disconnected from a meter with load current present. Leviton CTs are UL and cUL listed devices.

SOLID CORE

Leviton solid core CTs are cost effective and less susceptible to damage during installation. Solid core CTs slip over power lines to measure the electrical current flowing through the line. The CT “secondary” wires connect to the meter facilitating power and energy calculations. They are compact and cost effective. Solid core CTs are accurate (0.3% maximum error). For installation, power must be de-energized and the circuit opened in order to slip the CT over the power line.

SPLIT CORE

Split core CTs can be disassembled or ‘split’ into halves eliminating the need to turn power off and open the circuit during installation. This time-saving installation is ideal for critical loads that cannot be disconnected. Split core CTs close securely for fast, precise installation with no need for time-consuming tie wraps and no worries about improper seating or core half separation.

- Indoor type for measurement category Class IV, accessory equipment for energy meters
- Designed to meet the requirements of UL916 plus CSA C22.2 No. 61010-1
- Suitable for installation on 600V uninsulated bus duct

ROGOWSKI COIL

Rogowski Coil CTs are flexible rope style CTs with high amperage ranges from 20-5000A. The coil opens at the connector junction for fast and easy installation into an existing cable or bus bar. The Rogowski Coil’s flexible core is ideal for tight enclosures and odd-sized conductors with three length options: 12”, 18” and 24”. Rogowski Coil CTs are for use with VerifEye Series 4000 Industrial ModBus Meter Kits only.

APPLICATIONS

Use current transformers in commercial, institutional, industrial and government applications to support:

- Load profiling and benchmarking
- AMR/BAS/BMS/EMS integration
- Power quality analysis
- Usage aggregation
- Tenant cost allocation
- Measurement and verification
- Net metering
- Energy conservation and cost reduction
- Green building initiatives and government mandates

DIMENSIONAL DIAGRAMS

SPLIT CORE—FOR USE WITH SERIES 1000, 2000, 3500, 8000 METERS AND SERIES 2000 MULTIPLE METER UNITS (MMUs) ONLY

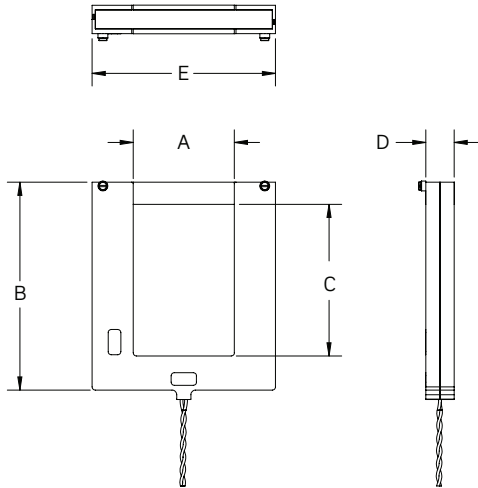

SPLIT CORE—FOR USE WITH SERIES 1000, 2000, 3500, 8000 METERS AND SERIES 2000 MULTIPLE METER UNITS (MMUs) ONLY

CT Size	A	B	C	D	E
100:0.1A	0.75" (19.05mm)	2.53" (64.16mm)	0.75" (19.05mm)	0.95" (24.13mm)	2.58" (65.53mm)
200:0.1A	1.00" (25.4mm)	2.86" (72.64mm)	1.00" (25.4mm)	0.75" (19.05mm)	2.75" (69.85mm)
400:0.1A	1.50" (38.1mm)	3.31" (84.07mm)	1.50" (38.1mm)	1.07" (27.18mm)	3.74" (95mm)
800:0.1A	3.00" (76.2mm)	5.38" (136.65mm)	3.50" (88.9mm)	1.25" (31.75mm)	5.39" (136.91mm)
1200:0.1A	4.00" (101.6mm)	8.23" (209.04mm)	6.00" (152.4mm)	1.12" (28.45mm)	7.25" (184.15mm)
1600:0.1A	4.00" (101.6mm)	8.23" (209.04mm)	6.00" (152.4mm)	1.12" (28.45mm)	7.25" (184.15mm)
3000:0.1A	5.00" (127mm)	9.86" (250.44mm)	7.00" (177.8mm)	1.44" (36.58mm)	8.44" (214.38mm)
5000:0.1A	5.00" (127mm)	9.86" (250.44mm)	7.00" (177.8mm)	1.44" (36.58mm)	8.44" (214.38mm)

SPLIT CORE—FOR USE WITH EMH+ AND SERIES 4000 & 4100 INDUSTRIAL MODBUS METER KITS ONLY

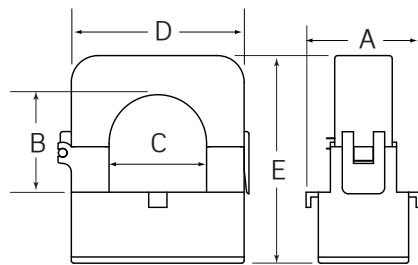

100 & 200A

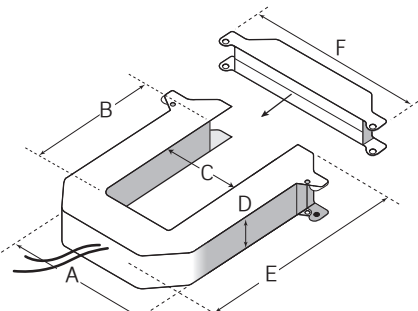

400 & 800A

SPLIT CORE—FOR USE WITH EMH+ AND SERIES 4000 & 4100 INDUSTRIAL MODBUS METER KITS ONLY

CT Size	A	B	C	D	E	F
100:0.333V	1.5" (38.10mm)	0.8" (20.32mm)	0.7" (17.78mm)	1.6" (40.64mm)	2.1" (53.34mm)	-
200:0.333V	1.5" (38.10mm)	1.25" (31.75mm)	1.25" (31.75mm)	2.25" (57.15mm)	2.8" (71.12mm)	-
400:0.333V & 800:0.333V	4.9" (124.46mm)	2.29" (58.16mm)	2.25" (63.5mm)	1.2" (30.48mm)	5.2" (132.08mm)	6.0" (152.40mm)

PRODUCT DATA

DIMENSIONAL DIAGRAMS
SOLID CORE—FOR USE WITH SERIES 8000 METERS, MINI METERS AND MMUs ONLY

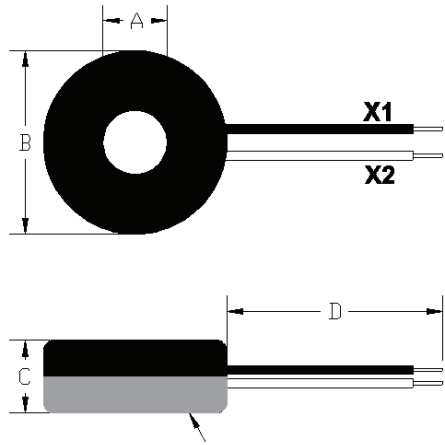

SOLID CORE—FOR USE WITH SERIES 8000 METERS, MINI METERS AND MMUs ONLY

CT Size	A	B	C	D
100:0.1A & 200:0.1A 0.67"	0.67" (17mm)	1.65" (42mm)	0.71" (18mm)	48.00" (1219mm)
100:0.1A & 200:0.1A 0.72"	0.72" (18.3mm)	2.06" (52.3mm)	0.82" (20.8mm)	48.00" (1219mm)
400:0.1A 1.5"	1.50" (38.1mm)	3.60" (76.2mm)	1.38" (34.9mm)	48.00" (1219mm)

NOTE: Lead lengths may be extended up to 500'. Consult factory for details

ROGOWSKI COIL—FOR USE WITH SERIES 4000 & 4100 INDUSTRIAL MODBUS METER KITS ONLY

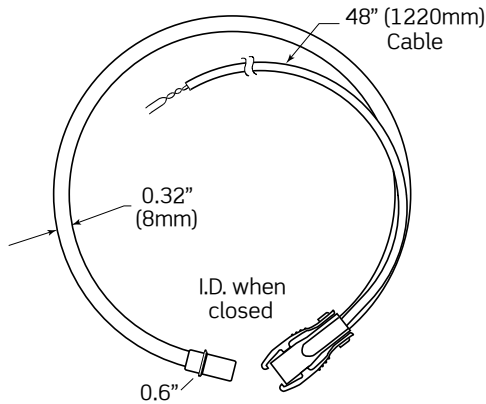

ROGOWSKI COIL—FOR USE WITH SERIES 4000 & 4100 INDUSTRIAL MODBUS METER KITS ONLY

LENGTH	INSIDE DIAMETER WITH CLOSED CONNECTOR
12" (305mm)	3.85" (98mm)
18" (458mm)	5.75" (147mm)
24" (610mm)	7.65" (195mm)

ORDERING INFORMATION

NOTE: Meters sold separately

Current Transformers

AMP	CAT. NO.	DESCRIPTION
SINGLES		
SOLID CORE—FOR USE WITH SERIES 8000 METERS, MINI METERS AND MMUs ONLY		
100:0.1A	CDE01-K11	Solid Core, 0.67", Black
100:0.1A	CDE01-L11	Solid Core, 0.67", Blue
100:0.1A	CDE01-R11	Solid Core, 0.67", Red
100:0.1A	CDA01-K12	Solid Core, 0.72", Black
100:0.1A	CDA01-L12	Solid Core, 0.72", Blue
100:0.1A	CDA01-R12	Solid Core, 0.72", Red
200:0.1A	CDE02-K11	Solid Core, 0.67", Black
200:0.1A	CDE02-L11	Solid Core, 0.67", Blue
200:0.1A	CDE02-R11	Solid Core, 0.67", Red
200:0.1A	CDA02-K12	Solid Core, 0.72", Black
200:0.1A	CDA02-L12	Solid Core, 0.72", Blue
200:0.1A	CDA02-R12	Solid Core, 0.72", Red
400:0.1A	CDF04-K24	Solid Core, 1.5", Black
SPLIT CORE—SERIES 1000, 2000, 3500 METERS, SERIES 8000 METERS AND SERIES 2000 (MMUs) ONLY		
100:0.1A	CTD01-K16	Split Core, .75" x .75"
200:0.1A	CTD02-K16	Split Core, 1" x 1"
400:0.1A	CTD04-K23	Split Core, 1.5", x 1.5"
800:0.1A	CTC08-K46	Split Core, 3" x 3.5"
1200:0.1A	CTC12-K46	Split Core, 4" x 6"
1600:0.1A	CTC16-K96	Split Core, 4" x 6"
3000:0.1A	CTC30-57B	Split Core, 5" x 7"
5000:0.1A	CTC50-57B	Split Core, 5" x 7"
SPLIT CORE—FOR USE WITH EMH+ AND SERIES 4000 & 4100 INDUSTRIAL MODBUS METER KITS ONLY		
100:0.333V	CTV01-K21	Split Core, 1.6" x 2.1"
200:0.333V	CTV02-K21	Split Core, 2.2" x 2.8"
400:0.333V	CTV04-K40	Split Core, 6" x 5.2"
800:0.333V	CTV08-K40	Split Core, 6" x 5.2"
ROGOWSKI COIL—FOR USE WITH SERIES 4000 & 4100 INDUSTRIAL MODBUS METER KITS ONLY		
20-5000A	CRV50-K62	Rogowski Coil, 12"
20-5000A	CRV50-K93	Rogowski Coil, 18"
20-5000A	CRV50-KC2	Rogowski Coil, 24"

AMP	CAT. NO.	DESCRIPTION
KITS—FOR USE WITH MINI-METERS AND MMUs ONLY		
100:0.1A	CDE01-211	CT Kit, 0.67", Red, Black
100:0.1A	CDE01-311	CT Kit, 0.67", Blue, Red, Black
100:0.1A	CDA01-212	CT Kit, 0.72", Red, Black
100:0.1A	CDA01-312	CT Kit, 0.72", Blue, Red, Black
200:0.1A	CDE02-211	CT Kit, 0.67", Red, Black
200:0.1A	CDE02-311	CT Kit, .067", Blue, Red, Black
200:0.1A	CDA02-212	CT Kit, 0.72", Red, Black
200:0.1A	CDA02-312	CT Kit, 0.72", Blue, Red, Black

Leviton recommends solid core transformers (CTs) for revenue-grade accuracy. Our 100A and 200A color coded CTs assist with correct installation by indicating phase monitored. Split core CTs are also available upon request for applications where power cannot be interrupted during installation. Our 100-5,000A split core and 20-5000A Rogowski Coil CTs offer +/-1.0% accuracy.

The following products are also part of the Leviton line of VerifEye integrated metering solutions:

- Series 1000 Meters
- Series 2000 Meters
- Series 3500 Meters
- Series 4000 & 4100 Industrial ModBus Meter Kits
- Series 8000 Meters
- EMH+ Integrated Meter & Hub
- Mini Meters
- Multiple Meter Units (MMUs)
- Energy Monitoring Software and Hardware